



**MAGNETROL®**

**AMETEK®**

MAGNETROL  
REGISTERED TO  
**ISO 9001**  
Your Assurance of  
Quality and Service

## J52 Refrigerant Level Switches

### Instruction Manual and Parts List



#### OPERATING PRINCIPLE

Figures 1 and 2 illustrate the simple and foolproof Magnetrol operating principle. Switching action is obtained through the use of a magnetic attracting sleeve, actuated by a float, and a switching mechanism. These two basic component assemblies are separated by a non-magnetic, pressure tight enclosing tube. The switch and magnet are assembled to a swinging arm which operates on precision stainless steel pivot sockets.

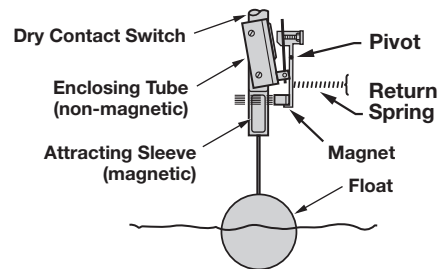

Normal Operating Level  
**Figure 1**

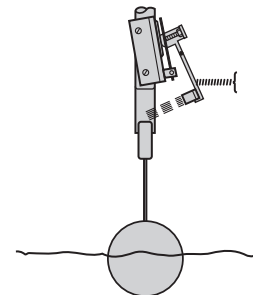

Falling Level  
**Figure 2**

#### DESCRIPTION

The Magnetrol® Model J52 is designed specifically as a refrigerant level control for applications with commercial refrigerants including Ammonia, Freon, Methyl Chloride, and Sulphur Dioxide. Usage may include level alarm and/or pump control service on liquid accumulators or receivers.

#### MODEL IDENTIFICATION

Housing	Switch	Connection	
		3/4" NPT	3/4" Socket Weld
NEMA 4X	Dry Contact	J52-4101-002	J52-4111-002
NEMA 4 Lexan	Dry Contact	J52-4107-004	—
NEMA 4X/7/9	Dry Contact	J52-4102-002	J52-4112-002

#### OPERATING CYCLE

At "Normal Operating Level" of liquid in the chamber (Figure 1), the float moves the magnetic attracting sleeve up the enclosing tube and into the field of the switch mechanism magnet. As a result, the magnet is drawn in tightly to the enclosing tube causing the switch to actuate, "making" or "breaking" an electrical circuit. As liquid level recedes, the float pulls the magnetic attracting sleeve downward until, at a pre-determined "Low Level" (Figure 2), the switch magnet releases and is drawn outward away from the enclosing body of the tube by a tension spring. This in turn deactuates the switch. When liquid level returns to normal (Figure 1), the float once again moves the magnetic attracting sleeve up at the enclosing tube, causing the switch to assume its original position.

# INSTALLATION

## PIPING

Figure 3 shows a typical piping schematic of Magnetrol J52 level switches installed on a liquid accumulator. Appropriate reference mark on control float chamber should be aligned to correspond with liquid level at which switch control is desired (switch operates at upper mark on increasing level and lower mark at decreasing level).

Use pipe of sufficient strength to support the control. All piping should be straight and free of "low spots" or "pockets" so that the lower liquid line will drain towards the liquid accumulator (or receiver), and upper vapor line will drain toward the control. Shut-off valves are recommended for installation between accumulator (or receiver), and control float chamber.

If control is to be used with a low temperature liquid (one which will "boil" in float chamber if outside heat is absorbed), the chamber and piping should be insulated. Such boiling in the chamber will cause false level indications. Do **NOT** insulate switch mechanism housing.

## MOUNTING

Adjust piping as required to bring control to a vertical position. Magnetrol controls must be mounted within three (3°) degrees of the vertical. A three-degree slant is noticeable by eye, but installation should be checked with a spirit level on top or sides of float chamber.

## WIRING

**CAUTION:** Level controls are shipped from the factory with the enclosing tube tightened and the middle set screw, on the housing base, locked to the enclosing tube. Failure to loosen the set screw prior to repositioning the conduit connection may cause the enclosing tube to loosen, resulting in the possible leakage of the process liquid or vapor.

The standard Model J52 with NEMA 4 housing is furnished with 24" (610 mm) long lead wires for ease in connection at a close junction box. Wires are sealed in a conduit outlet adaptor fitting, color coded and numbered to allow control wiring without the need to remove the sealed housing cover. All switch electrical ratings are stamped on the housing cover nameplate. If desired, conduit outlet may be repositioned for wiring convenience by loosening set screw(s) located under the housing base; however, housing cover must be removed and switch mechanism locking screw loosened so that mechanism can be rotated together with housing base.

**NOTE:** Before placing control into service, be certain cover gasketed joints are tight to prevent infiltration of moisture laden air or corrosive gases to the switch mechanism.

## TYPICAL INSTALLATIONS AND WIRING DIAGRAMS

INSTALLATION SHOWING PUMP CONTROL AND HIGH LEVEL ALARM

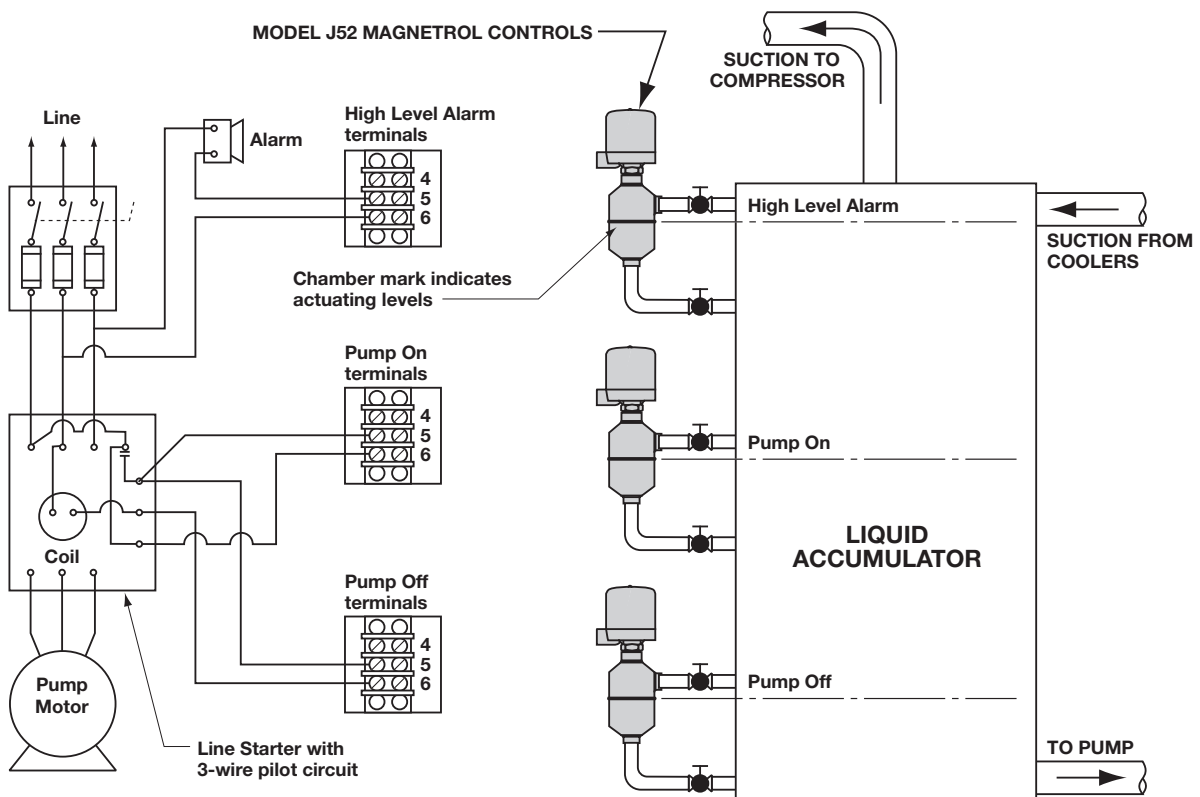

Figure 3

## INSTALLATION cont.

### WIRING cont.

Terminal connections shown in Figure 4 are for a standard SPDT switch. Actuating the switch closes one circuit and simultaneously opens the second circuit. In this diagram, circuit between contacts 4 and 5 is made and circuit between contact 5 and 6 is broken at low liquid level. At high level, circuit between contacts 4 and 5 is broken and circuit between contact 5 and 6 is made.

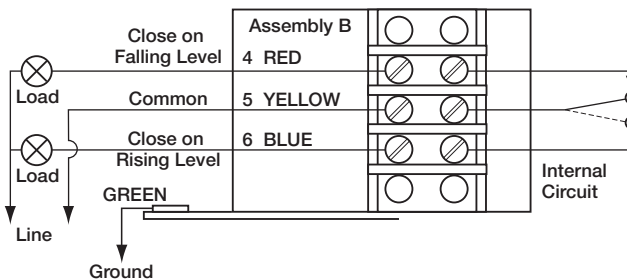

Figure 4

## DIFFERENTIAL ADJUSTMENT

The amount of level travel between “switch on” and “switch off” can be reduced from the maximum factory setting by raising the lower set of jam nuts. Minimum free play (differential) of magnetic sleeve is  $\frac{1}{32}$ ".

**CAUTION:** Before attempting any work on the control, be certain to pull disconnect switch or otherwise assure that electrical circuit(s) through control is deactivated. Close operating medium supply valve on controls equipment with pneumatic switch mechanisms.

1. Disconnect wiring from supply side of switch mechanism and electrical conduit or operating medium line connections to switch housing.
2. Perform system shut-down as required to relieve pressure from tank or vessel and drain off liquid “head” above control mounting position. Allow unit to cool.
3. Remove switch housing assembly by loosening enclosing tube nut located immediately below housing base. Refer to Figure 8 on page 7.

4. With switch housing removed, jam nuts and magnetic sleeve are now accessible, as shown in Figure 6. Raising the lower jam nuts will reduce the differential. As the first step in any adjustment procedure, the position of the upper and lower jam nuts should be established.

NEVER CHANGE SETTING OF UPPER JAM NUTS AS THEY SUPPORT FLOAT ASSEMBLY SO THAT IT CANNOT TOUCH BOTTOM OF CHAMBER.

5. Loosen and remove upper jam nuts, guide washer, and magnetic sleeve. Lower jam nuts may now be adjusted to reduce the differential.

NOTE: Be certain to tighten jam nuts securely after adjustment.

6. Replace magnetic sleeve on stem and position upper jam nuts to their original setting. Lock upper jam nuts to guide washer.
7. Reassemble control in reverse of steps 1 through 3, previously described.
8. Test switch actuation by varying liquid level in tank or vessel.

### INSTALLATION SHOWING LEVEL CONTROL (OR ALARM) ON A RECEIVER

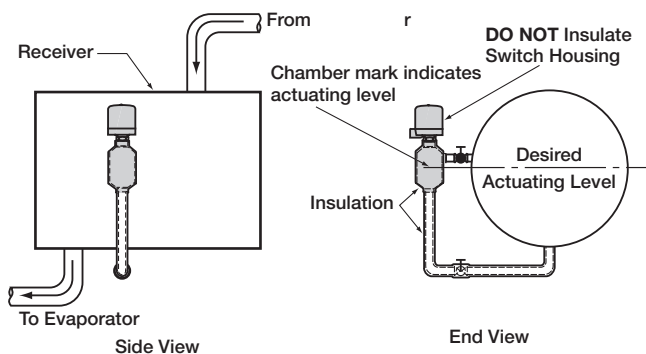

Mount control so mark on chamber corresponds to level desired in vessel. When control is used on a low temperature liquid, chamber and connection lines should be insulated as shown to prevent “boiling” in the float chamber and false level indications

Figure 5

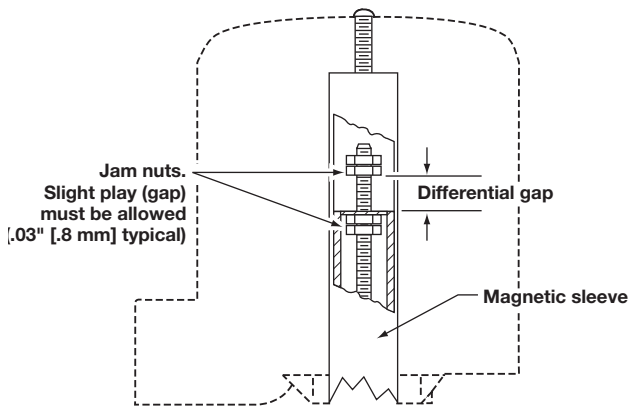

Figure 6

# PREVENTIVE MAINTENANCE

Periodic inspections are a necessary means to keep your Magnetrol control in good working order. This control is, in reality, a safety device to protect the valuable equipment it serves. Therefore, a systematic program of "Preventive Maintenance" should be implemented when control is placed into service. If the following sections on "What To Do" and "What To Avoid" are observed, your control will provide reliable protection of your capital equipment.

## What To Do

### 1. Keep Control Clean

- Be sure the switch housing cover is always in place on the control. This cover is designed to keep moisture laden air and corrosive gases as well as dirt away from the switch mechanism. In addition, it acts as a safety feature by keeping bare wires and terminals from being exposed. Be sure cover is tightened all the way down to ensure compression of quad ring seal. Should the housing cover become damaged or misplaced, order a replacement immediately.

### 2. Inspect Switch Mechanisms, Terminals, and Connections Monthly

- Switches should be inspected for excessive wear on actuating lever or misalignment of adjustment screw at point of contact between screw and lever. Such wear can cause false switch actuating levels.

Do **NOT** operate your control with defective or maladjusted switch mechanisms (refer to bulletin on switch mechanism furnished for service instructions).

- Magnetrol controls may sometimes be exposed to excessive heat or moisture. Under such conditions, insulation on electrical wires may become brittle, eventually breaking or peeling away. The resulting "bare" wires can cause short circuits. Check wiring carefully and replace at first sign or brittle insulation.
- Vibration may sometimes cause terminal screws to work loose. Check all terminal connections to be certain that screws are tight.

## What To Avoid

1. **NEVER** leave switch housing cover off the control longer than necessary to make routine inspections.
2. **NEVER** use lubrication on pivots of switch mechanisms. A sufficient amount of lubricant has been applied at the factory to ensure a lifetime of service. Further oiling is unnecessary and will only tend to attract dust and dirt which can interfere with mechanism operation.
3. **NEVER** place a jumper wire across terminals to "cut-out" the control. If a "jumper" is necessary for test purposes, be certain it is removed before placing control into service.
4. **NEVER** attempt to make adjustments or replace switches without reading instructions carefully. Certain adjustments provided for in Magnetrol controls should not be attempted in the field. When in doubt, consult the factory or your local representative.

# TROUBLESHOOTING

Usually the first indication of improper operation is failure of the controlled equipment to function, i.e. pump will not start (or stop), signal lights fail to light, etc. When these occur, whether at time of installation or during routine service thereafter, check the following potential external causes first.

- Fuses may be blown.
- Reset button(s) may need resetting.
- Power switch may be open.
- Controlled equipment may be faulty.
- Wiring lines leading to control may be defective.

If a thorough inspection of these possible conditions fails to locate the trouble, proceed next to a check of the controls switch mechanism.

1. Pull disconnect switch or otherwise assure that electrical circuit(s) through control deactivated.
2. Remove switch housing cover.
3. Swing magnet assembly in and out by hand to check carefully for any sign of binding. Assembly should require a minimum of force to move it through its full swing.
4. If binding exists, magnet may be rubbing enclosing tube or pivot sockets may be overly tight. Readjust pivot sockets as required until a slight amount of side play is evident. If magnet is rubbing, loosen magnet clamp screw and shift magnet position.
5. If switch magnet assembly swings freely and mechanism still fails to actuate, check installation of control to be certain it is within the specified three degrees of vertical (use spirit level on side of enclosing tube in two places, 90° apart).
6. Check the continuity of microswitch with ohmmeter. Replace immediately if defective.

**NOTE:** As a matter of good practice, spare switches should be kept on hand at all times.

If switch mechanism is operating satisfactorily, a test of the complete controls performance is the next likely step.

1. Reconnect power supply and carefully actuate switch mechanism manually (using a nonconductive tool) to determine whether controlled equipment will operate.

**CAUTION:** With electrical power “on”, care should be taken to avoid contact with switch leads and connections at terminal blocks.

2. If controlled equipment responds to manual actuation test, trouble may be located in the level sensing portion of the control (float, stem, and magnetic attraction sleeve).

**NOTE:** Check first to be certain refrigerant is entering float chamber. A valve may be closed or pipe line plugged.

3. Depressurize and remove E-tube, proceed to check level sensing action by removing switch housing assembly, as described in “Differential Adjustment” instructions.
4. Inspect attraction sleeve and inside of enclosing tube for excessive corrosion or solids buildup which could restrict movement, preventing sleeve from reaching field of switch magnet.
5. If differential adjustment has been changed in the field by repositioning the lower jam nuts on the float stem, check for tightness and position of the jam nuts.

**NOTE:** Differential adjustment affects a change in the amount of level travel between “switch-on” and “switch-off” actuations. Do **NOT** attempt adjustment without first consulting factory for assistance in computing level differential change for your control.

6. Check float to be certain it is buoyant in the refrigerant (float chamber must have adequate refrigerant level). If float is determined to be filled with liquid or collapsed, it must be replaced immediately. Do **NOT** attempt to repair a float.

If all components in the control are in operating condition, the trouble must be (and should be) located externally to the control. Repeat inspection of external conditions previously described.

**NOTE:** When in doubt about the condition or performance of a Magnetrol control, return it to the factory. See “Service Policy” on the back page.

# SPECIFICATIONS

## Agency approvals

Agency	Model Number	Approval
CSA	J52-41X1-00X	Non-Hazardous TYPE 4X
	J52-41X2-00X	
FM	J52-41XX-00X	Non-Hazardous NEMA 4X
	J52-41X2-00X	Class I, Div. 1, Groups C & D Class II, Div. 1 Groups E, F & G

## Basic electrical ratings

Voltage	Non-inductive Ampere Rating
	Dry Contact
120 VAC	15.00
240 VAC	15.00
24 VDC	6.00
120 VDC	0.50
240 VDC	0.25

## Dimensional specifications      Inches (mm)

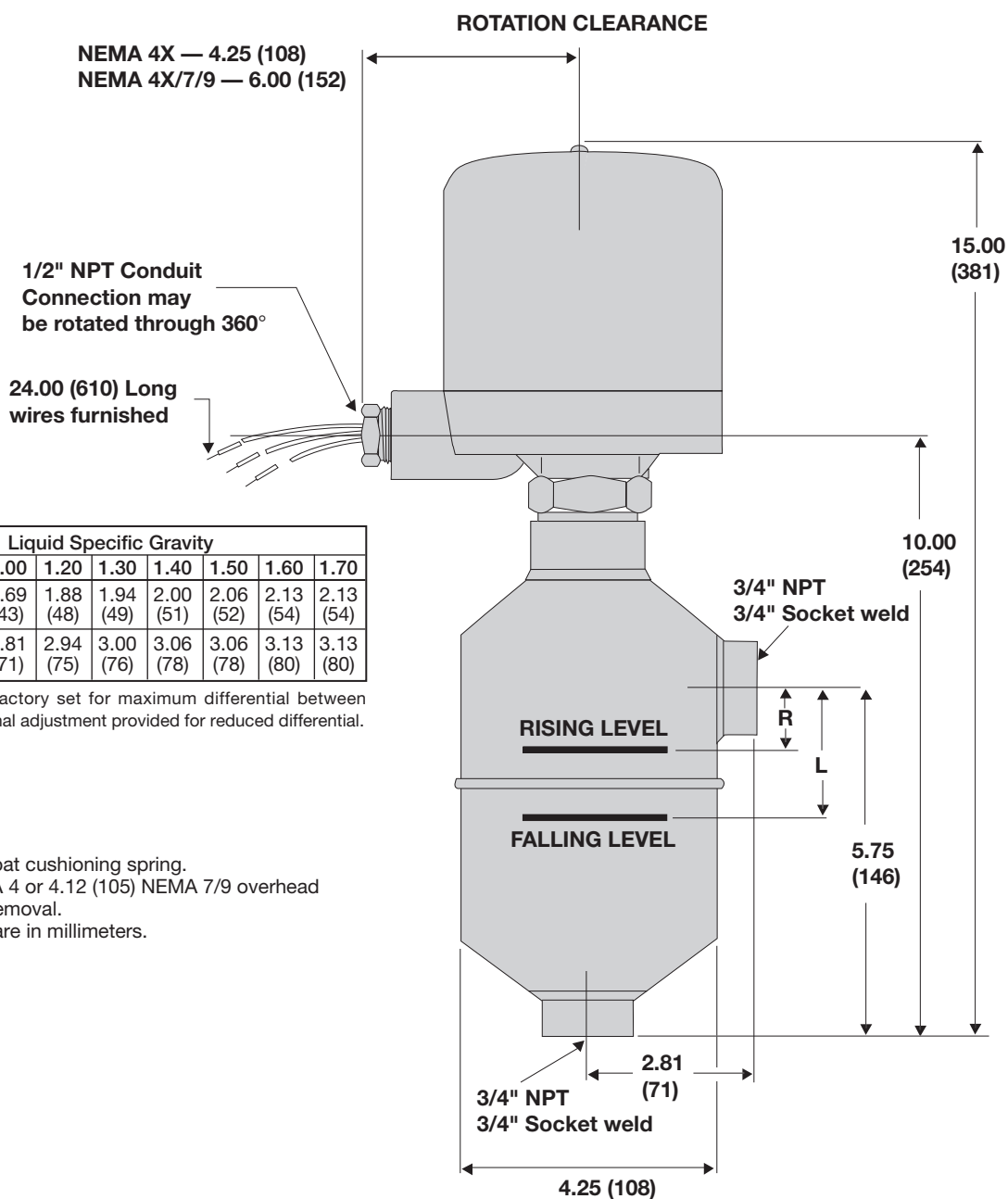

Actuating Levels	Liquid Specific Gravity								
	0.60	0.80	1.00	1.20	1.30	1.40	1.50	1.60	1.70
R	1.00 (25)	1.44 (37)	1.69 (43)	1.88 (48)	1.94 (49)	2.00 (51)	2.06 (52)	2.13 (54)	2.13 (54)
L	2.38 (60)	2.63 (69)	2.81 (71)	2.94 (75)	3.00 (76)	3.06 (78)	3.06 (78)	3.13 (80)	3.13 (80)

NOTE: Actuating levels are factory set for maximum differential between switch actuation. Internal adjustment provided for reduced differential.  
Levels  $\pm 0.25"$  (6 mm)

### NOTES:

1. Float chamber has float cushioning spring.
2. Allow 3.50 (89) NEMA 4 or 4.12 (105) NEMA 7/9 overhead clearance for cover removal.
3. All dimensions in ( ) are in millimeters.

Figure 7

# REPLACEMENT PARTS

Item	Description	J52-4101-002	J52-4102-002	J52-4107-004	J52-4111-002	J52-4112-002
1	Housing Cover	089-6526-001	089-6582-002	089-6522-001	089-6526-001	089-6582-002
2	Housing Base	089-6527-001		089-6527-001	089-6527-001	
3	Switch Mechanism	089-7401-102	089-7401-102	089-7401-102	089-7401-102	089-7401-102
4	E-Tube	Z32-6301-038	Z32-6325-001	Z32-6325-007	Z32-6301-038	Z32-6325-001
5	E-Tube Gasket	012-1301-002				
6	Attraction Sleeve	032-4101-013				
7	Chamber Assembly	Z33-3105-001			Z33-3107-001	Z33-3105-001
8	Jam Nuts (4)	010-2106-004				
9	Guide Washer	010-3351-001				

**NOTES:**

1. Replacement assemblies listed are furnished in kit form only for standard base model. Consult local representative for ordering assistance on special model replacement parts or accessories not included in above listing.
2. Conduit compression type seal fitting parts not available from factory for explosion proof housing which has 1" NPT outlet.

**IMPORTANT:**

When ordering, please specify:

- Model and Serial number of control.
- Name and Number of replacement assembly.

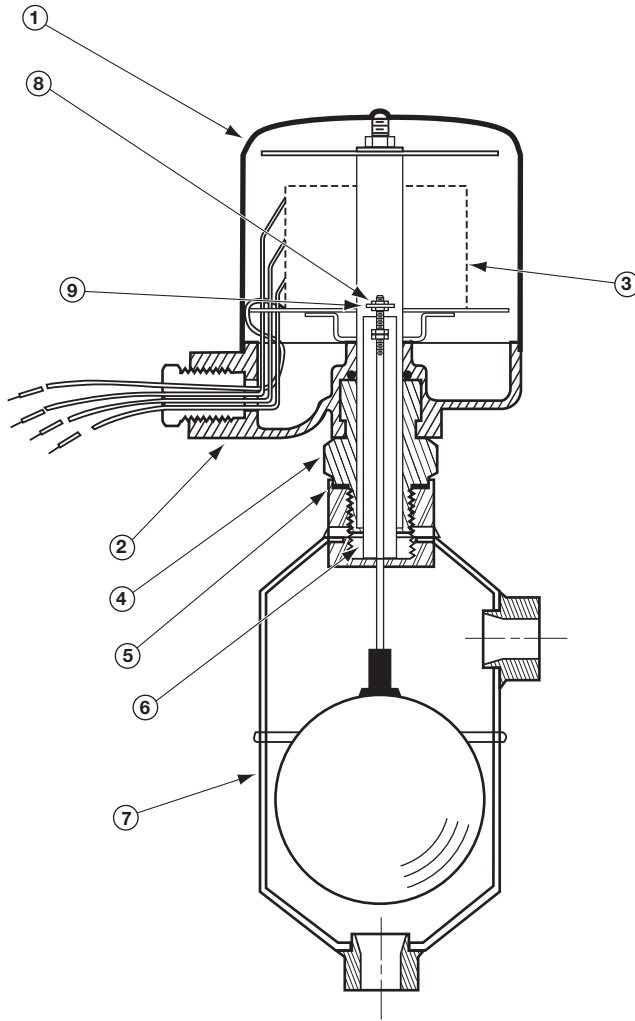

Figure 8

# IMPORTANT

## PRODUCT WARRANTY

All Magnetrol mechanical level and flow controls are warranted free of defects in materials or workmanship for three full years from the date of original factory shipment.

If returned within the warranty period; and, upon factory inspection of the control, the cause of the claim is determined to be covered under the warranty; then, Magnetrol will repair or replace the control at no cost to the purchaser (or owner) other than transportation.

Magnetrol shall not be liable for misapplication, labor claims, direct or consequential damage or expense arising from the installation or use of equipment. There are no other warranties expressed or implied, except special written warranties covering some Magnetrol products.

## QUALITY ASSURANCE

The quality assurance system in place at Magnetrol guarantees the highest level of quality throughout the company. Magnetrol is committed to providing full customer satisfaction both in quality products and quality service.

Magnetrol's quality assurance system is registered to ISO 9001 affirming its commitment to known international quality standards providing the strongest assurance of product/service quality available.

## ASSURED QUALITY & SERVICE COST LESS

## SERVICE POLICY

Owners of Magnetrol may request the return of a control or any part of a control for complete rebuilding or replacement. They will be rebuilt or replaced promptly. Controls returned under our service policy must be returned by Prepaid transportation. Magnetrol will repair or replace the control at no cost to the purchaser (or owner) other than transportation if:

1. Returned within the warranty period; and
2. The factory inspection finds the cause of the claim to be covered under the warranty.

If the trouble is the result of conditions beyond our control; or, is NOT covered by the warranty, there will be charges for labor and the parts required to rebuild or replace the equipment.

In some cases it may be expedient to ship replacement parts; or, in extreme cases a complete new control, to replace the original equipment before it is returned. If this is desired, notify the factory of both the model and serial numbers of the control to be replaced. In such cases, credit for the materials returned will be determined on the basis of the applicability of our warranty.

No claims for misapplication, labor, direct or consequential damage will be allowed.

## LOW VOLTAGE DIRECTIVE

For use in Category II installations. If equipment is used in a manner not specified by manufacturer, protection provided by equipment may be impaired.

## RETURN MATERIAL PROCEDURE

So that we may efficiently process any materials that are returned, it is essential that a "Return Material Authorization" (RMA) number be obtained from the factory, prior to the material's return. This is available through Magnetrol local representative or by contacting the factory. Please supply the following information:

1. Company Name
2. Description of Material
3. Serial Number
4. Reason for Return
5. Application

Any unit that was used in a process must be properly cleaned in accordance with OSHA standards, before it is returned to the factory.

A Material Safety Data Sheet (MSDS) must accompany material that was used in any media.

All shipments returned to the factory must be by prepaid transportation.

All replacements will be shipped F.O.B. factory.



705 Enterprise Street • Aurora, Illinois 60504-8149 USA  
630.969.4000 • info.magnetrol@ametek.com • magnetrol.com

Copyright © 2023 AMETEK Magnetrol USA, LLC

**BULLETIN: 46-627.5**  
**EFFECTIVE: August 2015**  
**SUPERSEDES: August 2010**