

Models F10 and F50 Installation and Operating Manual

Flow Switches



Model F10



Model F50



MAGNETROL®

AMETEK®

LEVEL MEASUREMENT
SOLUTIONS

Read this Manual Before Installing

This manual provides information on Model F10 and F50 Flow Switches. It is important that all instructions are read carefully and followed in sequence. Detailed instructions are included in the Installation section of this manual.

Conventions Used in this Manual

Certain conventions are used in this manual to convey specific types of information. General technical material, support data, and safety information are presented in narrative form. The following styles are used for notes, cautions, and warnings.

NOTES

Notes contain information that augments or clarifies an operating step. Notes do not normally contain actions. They follow the procedural steps to which they refer.

Cautions

Cautions alert the technician to special conditions that could injure personnel, damage equipment, or reduce a component's mechanical integrity. Cautions are also used to alert the technician to unsafe practices or the need for special protective equipment or specific materials. In this manual, a caution box indicates a potentially hazardous situation which, if not avoided, may result in minor or moderate injury.

Warnings

Warnings identify potentially dangerous situations or serious hazards. In this manual, a warning indicates an imminently hazardous situation which, if not avoided, could result in serious injury or death.

Safety Messages

Follow all standard industry procedures for servicing electrical equipment when working with or around high voltage. Always shut off the power supply before touching any components.

WARNING! Explosion hazard. Do not connect or disconnect equipment unless power has been switched off or the area is known to be non-hazardous.

Low Voltage Directive

For use in Installation Category II, Pollution Degree 2. If equipment is used in a manner not specified by the manufacturer, protection provided by the equipment may be impaired.

Warranty

All AMETEK LMS mechanical level and flow controls are warranted free of defects in materials or workmanship for three full years from the date of original factory shipment.

If returned within the warranty period; and, upon factory inspection of the control, the cause of the claim is determined to be covered under the warranty; then, AMETEK LMS will repair or replace the control at no cost to the purchaser (or owner) other than transportation.

AMETEK LMS shall not be liable for misapplication, labor claims, direct or consequential damage or expense arising from the installation or use of equipment. There are no other warranties expressed or implied, except special written warranties covering some AMETEK LMS products.

Quality Assurance

The quality assurance system in place at AMETEK LMS guarantees the highest level of quality throughout the company. AMETEK LMS is committed to providing full customer satisfaction both in quality products and quality service.

The AMETEK LMS quality assurance system is certified to ISO 9001, affirming our commitment to internationally recognized quality management standards and continuous improvement.

Copyright © 2024 AMETEK Magnetrol USA, LLC.

Performance specifications are effective with date of issue and are subject to change without notice. AMETEK LMS reserves the right to make changes to the product described in this manual at any time without notice. Magnetrol makes no warranty with respect to the accuracy of the information in this manual.

Models F10 and F50 Flow Switches

Table of Contents

| | | | |
|---|-----------|--|-----------|
| 1.0 Introduction | | 4.0 Reference Information | 12 |
| 1.0.1 Model F10 | 4 | 4.1 Troubleshooting | 12 |
| 1.0.2 Model F50 | 4 | 4.1.1 Check Switch Mechanism | 12 |
| 1.1 Principle of Operation | 4 | 4.1.2 Test Control's Performance | 13 |
| 1.1.1 Model F10 | 4 | 4.2 Agency Approvals | 14 |
| 1.1.2 Model F50 | 4 | 4.2.1 Specific Conditions of Use | 18 |
| 1.2 Operating Cycle | 4 | 4.3 Specific Gravity | 19 |
| 1.2.1 Model F10 | 4 | 4.3.1 Model F10 and F50 Specific Gravity | |
| 1.2.2 Model F50 | 5 | Correction | 19 |
| 2.0 Installation | 5 | 4.4 Specifications | 20 |
| 2.1 Unpacking | 5 | 4.4.1 Model F10 Actuating Flow Rates | 20 |
| 2.2 Piping | 5 | 4.4.2 Model F50 Actuating Flow Rates | 22 |
| 2.2.1 Model F10 | 5 | 4.4.3 Model F10 Dimensional | |
| 2.2.2 Model F50 | 5 | Specifications | 23 |
| 2.3 Mounting | 6 | 4.4.4 Model F50 Dimensional | |
| 2.3.1 Model F10 Mounting – | | Specifications | 24 |
| Threaded Connection | 6 | 4.5 Replacement Parts | 25 |
| 2.3.1.1 Installation of F10 in Horizontal | | 4.5.1 Model F10 | 25 |
| Line | 6 | 4.5.1.1 Model F10 Parts Identification | 25 |
| 2.3.1.2 Positioning Vane Perpendicular | | 4.5.1.2 Model F10 Switch and Housing | |
| to Flow | 6 | Reference | 25 |
| 2.3.1.3 Trimming Vane to fit Horizontal | | 4.5.1.3 Model F10 Threaded Mounting | 26 |
| Line Size | 7 | 4.5.1.4 Model F10 Flanged Mounting | 26 |
| 2.3.1.4 Final Mounting | 7 | 4.5.2 Model F50 | 27 |
| 2.3.2 Model F10 – Flanged Connection | 8 | 4.5.2.1 Model F50 Parts Identification | 27 |
| 2.3.3 Model F50 Mounting | 8 | 4.5.2.2 Model F50 Switch and Housing | |
| 2.3.3.1 Installation of Model F50 | 8 | Reference | 27 |
| 2.4 Wiring | 8 | 4.5.2.3 Model F50 Bronze Body | |
| 2.4.1 Model F10 Switch Actuation | | Replacement Parts | 28 |
| Adjustment | 9 | 4.5.2.4 Model F50 Stainless Steel | |
| 3.0 Preventive Maintenance | 10 | Replacement Parts | 28 |
| 3.1 Recommended Practice | 10 | 4.6 Model Numbers | 29 |
| 3.1.1 Keep Control Clean | 10 | 4.6.1 Model F10 | 29 |
| 3.1.2 Inspect Switch Mechanisms, | | 4.6.2 Model F50 | 30 |
| Terminals, and Connections Monthly | 10 | | |
| 3.1.3 Inspect Entire Unit Periodically | 11 | | |
| 3.2 What To Avoid | 11 | | |

1.0 Introduction

1.0.1 Model F10

F10 vane-actuated flow switches provide excellent reliability for a broad spectrum of horizontal pipe flow-sensing applications, including air, oil and petroleum derivatives, corrosive chemicals, and water.

1.1 Principle of Operation

1.1.1 Model F10

The flow of liquid or gas through a pipeline applies a force to a flow vane inserted into the pipeline. When flow is sufficient such that the force on the vane moves the vane, it is pivoted up, parallel to the flow. This movement causes an attraction sleeve to move into the field of a magnet. The magnet moves toward the sleeve causing actuation of the switch.

1.1.2 Model F50

The flow of liquid through the valve body applies a force to a flow disc. This in turn raises the magnetic sleeve, within its sealed non-magnetic enclosing tube into the field of the switch magnet, located outside the enclosing tube, actuating the attached switch mechanism.

1.2 Operating Cycle

1.2.1 Model F10

Sufficient flow through a pipeline causes the pivoted vane assembly to swing in the direction of the flow. The vane assembly rotates a cam which lifts an attraction sleeve, which in turn causes the magnet to pull in and actuate the switch.

The O-ring sealed adjusting screw, in the top of the enclosing tube, compresses the range spring located above the attraction sleeve. Turning the adjusting screw clockwise, increases the flow rate at which the switch actuates. Adjustments can be made while the flow switch is in service.

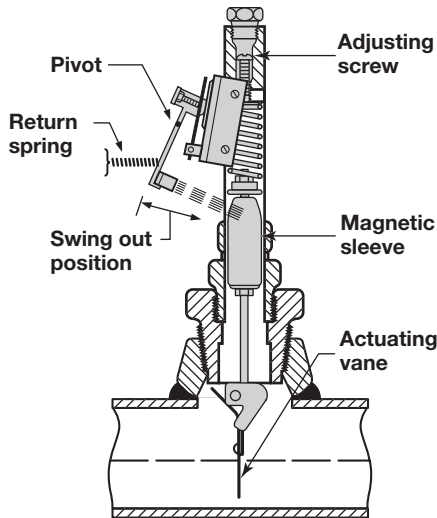

Figure 1—No Flow Position

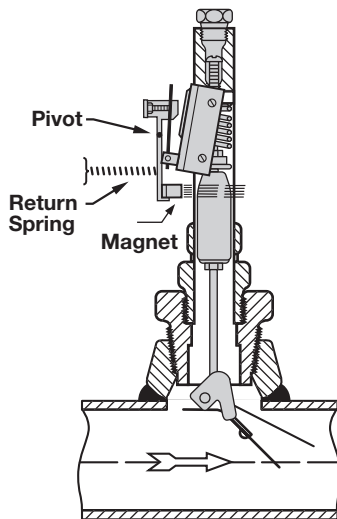

Figure 2—Position w/Actuating Flow Present

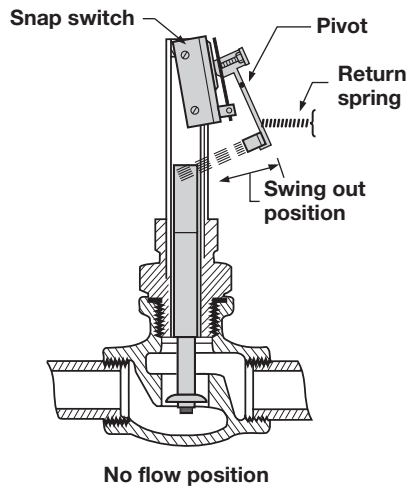

Figure 3—No Flow Position Figure

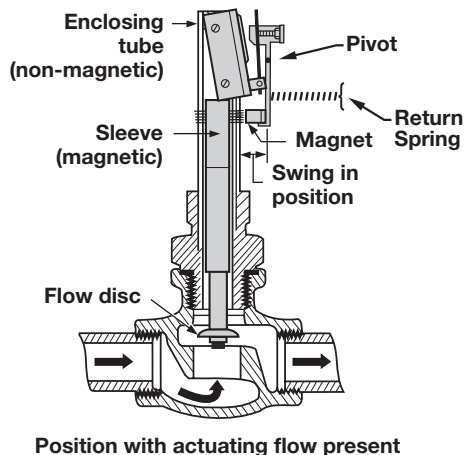

Figure 4—Position w/Actuating Flow Present

1.2.2 Model F50

On an increasing flow rate, the flow disc moves the attraction sleeve up within the field of a switch magnet, drawing it in tightly to the enclosing tube. This causes the switch to make or break an electrical circuit. When the flow rate drops, below the rate for which the flow disc is calibrated, the attraction sleeve is pulled downward until, at a predetermined low flow rate, the switch magnet releases and swings outward, away from the enclosing tube, causing a reversal of the switching action.

2.0 Installation

This section provides detailed procedures for properly installing Model F10 and F50 Flow Switches.

2.1 Unpacking

Caution: If equipment is used in a manner not specified by the manufacturer, protection provided by the equipment may be impaired.

Unpack the instrument carefully, inspecting all components for damage. Report any concealed damage to the carrier within 24 hours. Check the contents of the carton/crate against those listed on the packing slip, and report any discrepancy to the factory. Check the part number on the nameplate to be certain it agrees with the part number shown on the packing slip and purchase order. Record the serial number for future reference when ordering parts.

2.2 Piping

NOTE: For proper performance, a straight pipe run of 12 pipe diameters up stream and 3 pipe diameters downstream of the switch is recommended.

2.2.1 Model F10

The F10 flow switch should be located in a horizontally run pipe with the arrow on the body bushing or mounting flange pointing in the direction of flow.

2.2.2 Model F50

The Model F50 flow switch should be located in a horizontal pipe run, with the arrow on the valve body pointing in the direction of flow. The switch housing must always be above the valve body.

2.3 Mounting

Caution: This instrument is intended for use in Installation Category II, Pollution Degree 2.

2.3.1 Model F10 Mounting – Threaded Connection

2.3.1.1 Installation of F10 in Horizontal Line

1. Insert a length of pipe in two inch, 3,000 lb. threadolet fitting.
2. Plumb the vertical center line of the fitting and trace around the fitting to locate center line of required 2.62 inch (67 mm) diameter hole. Refer to Figure 5.
3. Clean up inside edges of hole, and remove any slag on the bottom of line that could interfere with vane.
4. With fitting concentrically positioned over the 2.62 inch (67 mm) diameter hole, and the vertical center line held plumb (refer to Figure 6), tack weld the fitting at four equally spaced points. After tacking, remove .06 inch (2 mm) diameter spacer wire. Refer to Figure 5.

NOTE: A hole in the pipeline less than 2.62 inches (67 mm) in diameter will limit travel of the pivoted vane. If this condition cannot be avoided, the width of the vane should be reduced to 1.50 inches (38 mm) maximum.

IMPORTANT: For installation in 2-inch pipe lines, disregard 2.62-inch (67 mm) dimension and use inside of threadolet as template.

5. Proper operation of the F10 depends upon the vertical center line of the 2" NPT coupling being plumb within 3°. Keep fitting plumb while welding the continuous passes, according to threadolet manufacturers installation procedure.

2.3.1.2 Positioning Vane Perpendicular to Flow

1. With large and small vanes unassembled, tighten the F10 body bushing into the coupling on the pipeline, until one of the three decal flow arrows is pointing parallel with flow.
2. Mark the bushing thread, even with the top of the threadolet, as a reference point for trimming vane to correct length. Remove two arrows not parallel with the pipe.
3. Remove the F10 from pipeline.

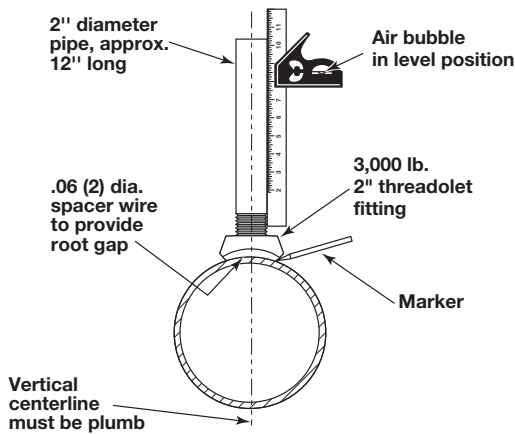

Figure 5

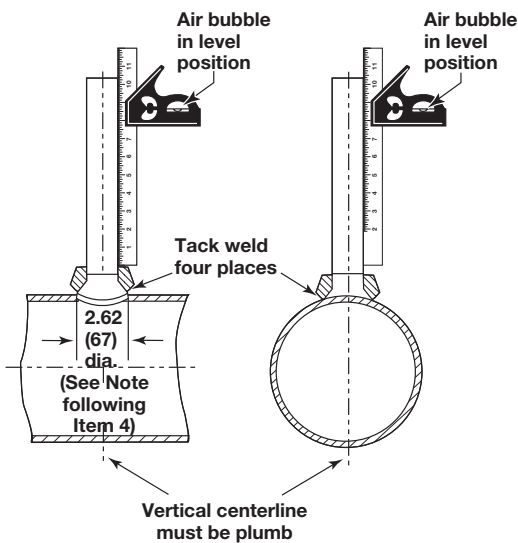

Figure 6

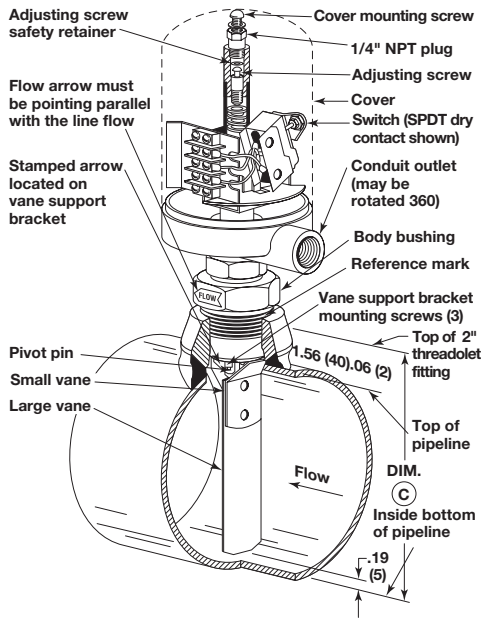

Figure 7

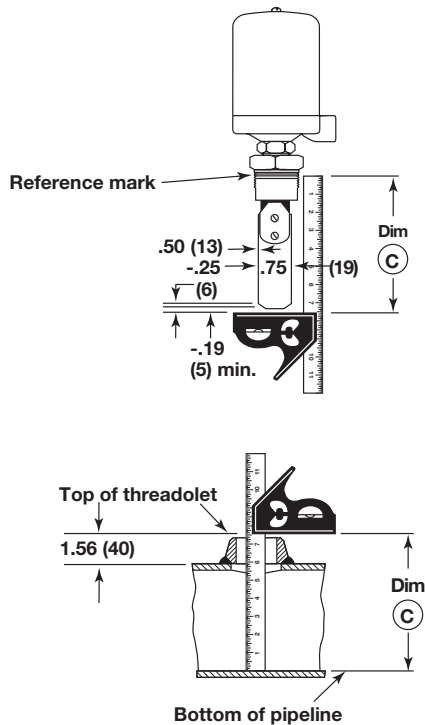

Figure 8

4. Check position of the arrow stamped on vane support bracket. This arrow should be pointing parallel with the flow arrow on the body bushing. Refer to Figure 7. If arrows are not parallel, remove the three vane support bracket mounting screws and rotate bracket until the stamped arrow is pointing parallel with the flow arrow; replace mounting screws.

2.3.1.3 Trimming Vane to Fit Horizontal Line Size

The F10 is furnished as standard with vanes suitable for use on 2-inch through 30-inch pipelines. Assemble vane (or vanes) to F10 and trim according to applicable line size as follows:

2-inch line (Sch. 40):

Use small vane only. No cutting should be necessary.

2½-inch line:

Use small vane, with large vane trimmed to 1½ inches wide (same as small vane) and length trimmed to dimension "C" less .19 inch (5 mm). Refer to Figure 8.

3-inch line and up:

Use small vane, with large vane trimmed to dimension "C" less .19 inch (5 mm). Refer to Figure 8. Upon final assembly of trimmed vanes, firmly tighten two screws.

It is recommended that the lower retaining screw be peened over on the threaded end.

2.3.1.4 Final Mounting

1. Apply sealing compound to body bushing threads.
2. Thread F10 into threadolet fitting and tighten body bushing to the same seal tight position so that the flow arrow is pointing parallel with the line flow. Refer to item #1, *Section 2.3.1.2, Positioning Vane Perpendicular to Flow.*
3. Connect conduit and power lines.

2.3.2 Model F10 — Flanged Connection

NOTE: For proper performance, a straight pipe run of 12 pipe diameters up stream and 3 pipe diameters downstream of the switch is recommended.

Figure 9 shows one method which may be used to mount the F10 flow switch to 2 1/2 to 30-inch run pipes. Before final welding, alignment of mounting flange should be checked to be certain it is plumb. Finished mounting must allow control switch housing to be within three degrees of vertical for proper operation. A three-degree slant is noticeable by eye, but installation should be checked with a spirit level.

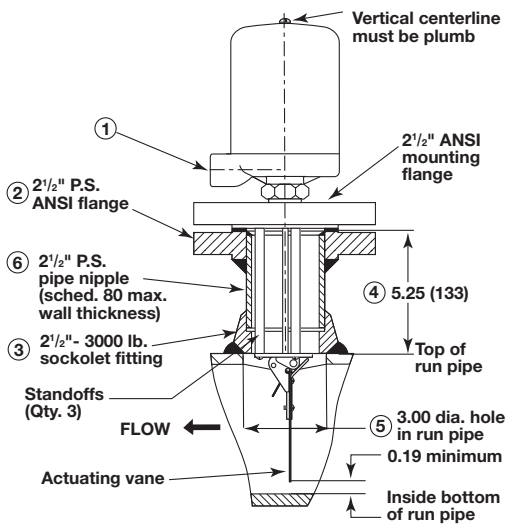

Figure 9

NOTES:

- ① Conduit outlet may be rotated 360° for wiring convenience.
- ② Flange to match flange of F10 flow switch and positioned with bolt holes straddling center lines.
- ③ For proper attachment procedure, refer to fitting manufacturer's recommendation.
- ④ Dimension shown is for use with 0.06 inch (2 mm) thick flange gasket. If thicker gasket is used, reduce dimension amount equal to additional thickness.
- ⑤ For run pipe sizes over 2.50 inch P.S. only. For installation on 2.50 inch run pipes, disregard 3.00 inch dimension and use inside of adaptor fitting as template.
- ⑥ Follow appropriate sections under threaded connection mounting to position the vane perpendicular to the flow and trim vane to size.
- ⑦ Consult factory for installations over Sch. 160 when using flanged Model F10.

2.3.3 Model F50 Mounting

2.3.3.1 Installation of Model F50

1. When installing, use wrenches on valve body only. Do not attempt to tighten or draw-up valve body on the pipe by pulling or pushing on switch housing cover.
2. Adjust pipe alignment, as required, to bring switch housing to a vertical position above pipeline. F50 flow switches must be mounted within three degrees of vertical. Three degree slant is noticeable to the eye, but installation should be check with a spirit level on the side of the enclosing tube at two places, 90 degrees apart.

NOTE: On flow switches using pneumatic switch assemblies, consult bulletin on mechanism furnished for air (or gas) piping instructions.

NOTE: For proper performance, a straight pipe run (12 pipe diameters upstream, and three pipe diameters downstream of the switch), is recommended.

2.4 Wiring

Caution: Level controls are shipped from the factory with the enclosing tube tightened and the middle set screw, on the housing base, locked to the enclosing tube. Failure to loosen the set screw prior to repositioning the conduit connection may cause the enclosing tube to loosen, resulting in the possible leakage of the process liquid or vapor.

NOTE: A switch or circuit breaker shall be installed in close proximity to equipment and within easy reach of operator. It shall be marked as the disconnecting device for the equipment.

1. On high temperature applications, above +250 °F (+121 °C), high temperature wire should be used between the control and first junction box located in a cooler area.

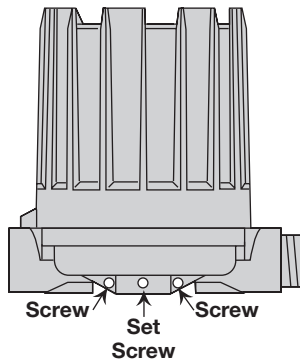

Figure 10

2. Remove switch housing to gain access to switch mechanism.

NOTE: For supply connections in installations with ambient temperature up to +70 °C, use wire with a minimum rating of +75 °C as required by the process conditions,. Installations with ambient temperatures up to +80 °C require wire with a minimum rating of +85 °C as required by the process conditions. Use a minimum of 14 AWG wire for power and ground field wires.

3. Pull in supply wires (conductors), wrap them around enclosing tube beneath the baffle plate, and connect to proper terminals. Ensure excess wire does not interfere with actuation of the switch, and that adequate clearance exists for replacement of switch housing cover.

4. Connect power supply to control and test switch actuation by varying flow rate within pipeline.

NOTE: If switch mechanism fails to function properly, check vertical alignment of control housing. Refer to installation bulletin of mechanism furnished, as listed in the switch mechanism chart on page 25.

5. Replace switch housing cover.

NOTE: NEMA 4X/7/9 housings must be sealed at the conduit outlet with suitable compound to prevent entrance of air. Check cover to base fit to be certain gasketed joint is tight. A positive seal is necessary to prevent infiltration of moisture laden air or corrosive gases into switch housing.

6. Place flow switch into service.

2.4.1 Model F10 Switch Actuation Adjustment

The F10 flow switch is factory set to actuate at the minimum flow rate. Actuation flow rate can be increased while the unit is in service, under pressure, by removing the ¼" NPT plug to gain access to the O-ring sealed adjusting screw. Each clockwise turn of the adjusting screw increases the actuating flow rate approximately 10% of the range of the specific flow vane being used. See pages 20–22 for flow rate adjustability.

Caution: The safety retainer above the adjusting screw is placed there to help prevent the accidental removal of the adjusting screw. Do not defeat its purpose by forcefully backing out the adjustment screw. Be sure to replace the ¼" NPT plug and tighten it firmly.

3.0 Preventive Maintenance

Periodic inspections are a necessary means to keep your flow switch in good working order. This control is a safety device to protect the valuable equipment it serves. A systematic program of preventive maintenance must be implemented when the control is placed into service. If the following is observed, your control will provide reliable protection of your capital equipment for many years.

3.1 Recommended Practice

3.1.1 Keep Control Clean

Be sure the switch housing cover is always in place on the control. This cover is designed to keep dust and dirt from interfering with the switch mechanism operation. In addition, it protects against damaging moisture and acts as a safety feature by keeping bare wires and terminals from being exposed. Should the housing cover, or any seals become damaged or misplaced, obtain a replacement immediately.

3.1.2 Inspect Switch Mechanisms, Terminals, and Connections Monthly

- a. Dry contact switches should be inspected for excessive wear on actuating lever or misalignment of adjustment screw at point of contact between screw and lever. Such wear can cause false switch actuating levels. Adjust switch mechanism to compensate (if possible) or replace switch.
- b. DO NOT operate your control with defective or - maladjusted switch mechanism (refer to bulletin on switch mechanisms furnished for service instructions).
- c. Controls may sometimes be exposed to excessive heat or moisture. Under such conditions, insulation on electrical wiring may become brittle, eventually breaking or peeling away. The resulting bare wires can cause short circuits.

Check wiring carefully, and replace it at the first sign of brittle insulation.
- d. Vibration may sometimes cause terminal screws to work loose. Check all terminal connections to be certain that screws are tight.
- e. On units with pneumatic switches, air (or gas) operating medium lines, subjected to vibration, may eventually crack or become loose at connections causing leakage. Check lines and connections carefully and repair or replace, if necessary.

NOTE: As a matter of good practice, spare switches should be kept on hand at all times.

3.1.3 Inspect Entire Unit Periodically

Increase and decrease liquid flow through the pipeline to check for switch contact and reset.

3.2 What To Avoid

1. NEVER leave switch housing cover off the control longer than necessary to make routine inspection.
2. NEVER place a jumper wire across terminals to cut-out the control. If a jumper is necessary for test purposes, be certain it is removed before placing control into service.
3. NEVER attempt to make adjustments or replace switches without reading instructions carefully. Certain adjustments provided for in flow switches should not be attempted in the field. When in doubt, consult the factory or your local representative.
4. NEVER use lubricants on pivots of switch mechanisms. A sufficient amount of lubricant has been applied at the factory to ensure a lifetime of service. Further lubrication is unnecessary, and will only tend to attract dust and dirt which can interfere with mechanism operation.

4.0 Reference Information

4.1 Troubleshooting

Usually the first indication of improper operation is failure of the controlled equipment to function, i.e., pump will not start (or stop), signal lights fail to light, etc. When these symptoms occur, whether at time of installation or during routine service thereafter, check the following potential external causes first.

- a. Fuses may be blown.
- b. Reset button(s) may need resetting.
- c. Power switch may be open.
- d. Controlled equipment may be faulty.

If a thorough inspection of these possible conditions fails to locate the trouble, proceed to a check of the control's switch mechanism.

4.1.1 Check Switch Mechanism

1. Pull disconnect switch, or otherwise assure that electrical circuit(s) of control are deactivated.
2. Remove switch housing cover.
3. Swing magnet assembly in and out by hand, checking carefully for any sign of binding. Assembly should require minimal force to move it through its full swing.
4. If binding exists, magnet may be rubbing enclosing tube. If magnet is rubbing, loosen magnet clamp screw, and shift magnet position.
5. If switch magnet assembly swings freely, and mechanism still fails to actuate, check installation of control to be certain it is within the specified three degrees of vertical. Use a spirit level on side of enclosing tube in two places, 90 degrees apart.

NOTE: As a matter of good practice, spare switches should be kept on hand at all times.

If switch mechanism is operating satisfactorily, a test of the complete control's performance is the next likely step.

4.1.2 Test Control's Performance

If switch mechanism is operating satisfactorily, a test of the complete control's performance is the next likely step.

1. Reconnect power supply, and carefully actuate switch mechanism manually, using a non-conductive tool, to determine whether controlled equipment will operate.

Caution: With electrical power on, care should be taken to avoid contact with switch leads and connections at terminal block.

2. If controlled equipment responds to manual actuation test, trouble may be located in the flow sensing portion of the control.

NOTE: Check first to be certain liquid is flowing through pipeline. A valve may be closed, or pipeline may be plugged.

3. If magnet fails to pull in on increasing flow:
 - a. Disk or vane may not be sized properly for required actuation flow rate.
 - b. Check for hang-up or deposits in disk seat or at vane pivot.
 - c. Check for malfunctioning by manually moving magnet carriage.
4. If magnet fails to pull out on decreasing flow:
 - a. Disk or vane may not be sized properly for required actuation flow rate.
 - b. Check for hang-up or deposits in disk seat or at vane pivot.
 - c. Check for malfunctioning by manually moving magnet carriage.

If all components in the unit are in operating condition, the trouble must be located external to the unit. Repeat inspection of external conditions previously described.

4.2 Agency Approvals



EMC directive 2014/30/EU (electromagnetic compatibility)
 The following standard has been applied:
 EN 61326-1:2013-(Low Voltage Directive-CE)





MAGNETROL / **AMETEK**
705 ENTERPRISE ST AURORA, IL 60504 USA



 T Y 4X
 C U S P E
 APPROVED

MODEL NO
 SERIAL NO

INPUT: AMB TEMP: -40°C TO +70°C
 OUTPUT: MAX.PRESS:

Approval: FM Type 4X **005-8047-003**
 Housing Material: Carbon Steel/Aluminum

MAGNETROL / **AMETEK**
705 ENTERPRISE ST AURORA, IL 60504 USA

 T Y 4X
 C U S P E
 APPROVED

MODEL NO
 SERIAL NO

INPUT: AMB TEMP: -40°C TO +70°C
 OUTPUT: MAX.PRESS:

MANUF YEAR:
 FM21US0099X\FM21CA0066X
 CL I DIV 1 GPS B,C,D T6...T1
 CL II DIV 1 GPS E,F,G
 CL III SINGLE SEAL

SEAL AT THE ENCLOSURE/
 SCELLER A L ENCEINTE

IP66 SINGLE SEAL

005-8049-009
 Approval: FM US/CA
 Housing Material: Aluminum

MAGNETROL / **AMETEK**
705 ENTERPRISE ST AURORA, IL 60504 USA

 T Y 4X
 C U S P E
 APPROVED

MODEL NO
 SERIAL NO

INPUT: AMB TEMP: -40°C TO +70°C
 OUTPUT: MAX.PRESS:

MANUF YEAR:
 FM21US0099X\FM21CA0066X
 CL I DIV 1 GPS B,C,D T6...T1
 CL II DIV 1 GPS E,F,G
 CL III SINGLE SEAL

SEAL AT THE ENCLOSURE/
 SCELLER A L ENCEINTE

IP66 SINGLE SEAL

005-8049-072
 Approval: FM US/CA
 Housing Material: Cast Iron

Maximum Pressure Ratings:

These are the ranges of process pressure ranges based on each individual model as mention in each individual manual.

| Nominal Thickness (in) | Minimum Thickness (in) | Pressure Rating for 316 SST Version (psig) |
|------------------------|------------------------|--|
| 0.035 | 0.0295 | 1300 |
| 0.065 | 0.0595 | 2710 |
| 0.093 | 0.087 | 5000 |

When the equipment is installed in process temperatures higher than +85°C the temperature classification must be increased according to the following table as per IEC60079-0.

| Maximum Process Temperature | Temperature Classification |
|-----------------------------|----------------------------|
| <85°C | T6 |
| <100°C | T5 |
| <135°C | T4 |
| <200°C | T3 |
| <300°C | T2 |
| <450°C | T1 |

Additional Approvals:

- Series C, U, W, and X switch mechanisms, along with Tuffy T3X designs, in Aluminum or Cast Iron housings, are certified for Ex ia IIC T6 Ga per Certificate No. IECEx KIWA 18.0011X and ATEX II 1 G Ex ia IIC T6 Ga per Certificate No. KIWA 18ATEX0022 X Issue: 1.
- Series HS, F, 8, and 9 switch mechanisms, in Type 4X housings, are CSA certified for Class I, Div 2, Groups A, B, C & D.

Switch Ratings

| SWITCH SERIES | SWITCH TYPE | PROCESS TEMP RANGE | LOAD | RATING | | | | | |
|---------------|--------------------------|-------------------------------------|--|------------------------|-----------------------|---------------------|-------------------|----------------------|---------------------------|
| | | | | VOLTS AC | | | VOLTS AC | | |
| | | | | 120 | 240 | 480 | 24 | 120 | 240 |
| B | Snap | -40 to +250 °F (-40 to +121 °C) | Non-Inductive Amp Inductive Amp Horsepower | 15.00 15.00 1/8 | 15.00 15.00 1/8 | 15.00 15.00 — | 6.00 5.00 — | 0.50 0.05 — | 0.25 0.03 — |
| C | Snap | -40 to +450 °F (-40 to +232 °C) | Non-Inductive Amp Inductive Amp Horsepower | 15.00 15.00 1/10 | 15.00 15.00 1/6 | 15.00 15.00 — | 6.00 5.00 — | 1.00 — — | 0.50 — — |
| D | Snap | -40 to +250 °F (-40 to +121 °C) | Non-Inductive Amp Inductive Amp Horsepower | 10.00 3.80 1/8 | — — — | — — — | 10.00 — — | 10.00 2.20 1/8 | 1.50 Min 3.00 Max — |
| F | Hermetic | -50 to +750 °F (-46 to +399 °C) | Resistive Amp Inductive Amp | 2.50 2.50 | — — | — — | 4.00 2.00 | 0.30 0.10 | — — |
| G | Snap | -40 to +250 °F (-40 to +121 °C) | Non-Inductive Amp Inductive Amp Horsepower | 15.00 15.00 1/8 | 15.00 15.00 1/4 | 15.00 15.00 — | 6.00 5.00 — | 0.50 0.05 — | 0.25 0.03 — |
| H | Snap | -40 to +450 °F (-40 to +232 °C) | Non-Inductive Amp Inductive Amp Horsepower | 5.00 5.00 1/10 | 5.00 5.00 1/6 | 5.00 5.00 — | 5.00 4.00 — | 0.50 0.05 — | 0.25 0.03 — |
| HS | Hermetic | -50 to +550 °F (-46 to +288 °C) | Resistive Amp Inductive Amp Horsepower | 5.00 — 1/8 | 5.00 — 1/4 | — — — | 5.00 3.00 — | 0.50 — — | 0.25 — — |
| I | Snap | -40 to +250 °F (-40 to +121 °C) | Non-Inductive Amp Inductive Amp Horsepower | 10.00 3.80 1/8 | — — — | — — — | — — — | 10.00 2.20 1/8 | 1.50 Min 3.00 Max — |
| O | Snap | -40 to +450 °F (-40 to +232 °C) | Non-Inductive Amp Inductive Amp Horsepower | 5.00 5.00 1/10 | 15.00 15.00 1/6 | 15.00 15.00 — | — — — | 1.00 — — | 0.50 — — |
| Q | Snap | -40 to +250 °F (-40 to +121 °C) | Non-Inductive Amp Inductive Amp Horsepower | 15.00 15.00 1/8 | 15.00 15.00 1/4 | 15.00 15.00 — | 6.00 5.00 — | 0.50 0.05 — | 0.25 0.03 — |
| R | Snap | -50 to +1000 °F (-46 to +538 °C) | Non-Inductive Amp Inductive Amp | 1.00 1.00 | 1.00 1.00 | — — | 1.00 1.00 | 0.40 0.40 | — — |
| U | Snap Gold Contacts | -50 to +550 °F (-46 to +288 °C) | Resistive Amp Inductive Amp | 1.00 1.00 | — — | — — | — — | — — | — — |
| W | Snap Gold Contacts | -50 to +450 °F (-46 to +232 °C) | Resistive Amp Inductive Amp | 1.00 — | 1.00 0.80 | — — | 3.00 — | 0.50 — | — — |
| X | Snap Gold Contacts | -40 to +450 °F (-40 to +232 °C) | Resistive Amp Inductive Amp | 0.50 0.15 | 0.50 — | — — | 0.50 — | 0.50 — | 0.50 — |
| 8 | Hermetic Snap | -50 to +750 °F (-46 to +399 °C) | Non-Inductive Amp Inductive Amp | 1.00 1.00 | — — | — — | 3.00 1.00 | — — | — — |
| 9 | Hermetic Snap | -50 to +1000 °F (-46 to +538 °C) | Non-Inductive Amp Inductive Amp | 1.00 1.00 | — — | — — | 1.00 1.00 | — — | — — |

| Item | Description/Ratings |
|--------------------------------|---|
| Installation and Erection | TO PREVENT IGNITION OF HAZARDOUS ATMOSPHERES. DISCONNECT DEVICE FROM SUPPLY CIRCUIT BEFORE OPENING. KEEP ASSEMBLY TIGHTLY CLOSED WHEN IN OPERATION. |
| | Before attempting to remove a switch mechanism, be certain to pull disconnect switch or otherwise assure that electrical circuit through control is de-energized. |
| | Low Voltage Directive For use in Installations Category II, Pollution Degree 2. If equipment is used in a manner not specified by the manufacturer, protection provided by equipment may be impaired. |
| Use and setting up (operation) | TO PREVENT IGNITION OF HAZARDOUS ATMOSPHERES. DISCONNECT DEVICE FROM SUPPLY CIRCUIT BEFORE OPENING. KEEP ASSEMBLY TIGHTLY CLOSED WHEN IN OPERATION. |
| | Before attempting to remove a switch mechanism, be certain to pull disconnect switch or otherwise assure that electrical circuit through control is de-energized. |
| Maintenance and Repair | Before attempting to remove a switch mechanism, be certain to pull disconnect switch or otherwise assure that electrical circuit through control is de-energized. |
| | For additional information, see applicable manual for specific instructions. |

4.2.1 Specific Conditions of Use

1. The flamepaths of the equipment are not intended to be repaired. Consult the manufacturer if repair of the flamepath joints is necessary.
2. Refer to the manufacturer's instructions to reduce the potential of an electrostatic charging hazard on the equipment enclosure.
3. The cast iron enclosure for ATEX, UKEX and IECEx certification does not contain an IP rating.
4. The cast iron enclosure for North American certification does not contain a Type 4X rating.
5. For installation with ambient temperature of 70°C, refer to the manufacturer's instruction for guidance on proper selection of conductors.

4.3 Specific Gravity

4.3.1 Model F10 and F50 Specific Gravity Correction

To determine the actuating flow rates for liquids other than water (approximate viscosity of 20 centistokes or less), a specific gravity correction factor must be applied to the water flow rates given in the table.

Example: The maximum adjustment for an increasing flow rate with a liquid specific gravity of .70 in an 8" line is: 230 GPM x 1.20 = 276 GPM.

| Specific Gravity | Multiplication Factor | Specific Gravity | Multiplication Factor |
|------------------|-----------------------|------------------|-----------------------|
| .40 | 1.58 | .95 | 1.03 |
| .45 | 1.49 | 1.00 | 1.00 |
| .50 | 1.41 | 1.05 | .98 |
| .55 | 1.35 | 1.10 | .95 |
| .60 | 1.29 | 1.15 | .93 |
| .65 | 1.24 | 1.20 | .91 |
| .70 | 1.20 | 1.25 | .89 |
| .75 | 1.15 | 1.30 | .88 |
| .80 | 1.12 | 1.35 | .86 |
| .85 | 1.08 | 1.40 | .85 |
| .90 | 1.05 | 1.45 | .83 |

4.4 Specifications

4.4.1 Model F10 Actuating Flow Rates

Water Service GPM

Model F10 units may be adjusted in service to actuate within the minimum and maximum flow rates given below. A specific gravity correction factor is applied for liquids other than water (1.00 specific gravity).

| Pipe Line Size Inches ^① | Flow Increase (GPM) | | Flow Decrease (GPM) | |
|---------------------------------------|---------------------|----------------------|---------------------|---------|
| | Minimum | Maximum ^② | Minimum | Maximum |
| 2 | 21 | 63 | 16 | 48 |
| 2½ | 26 | 74 | 20 | 56 |
| 3 | 32 | 88 | 24 | 65 |
| 3½ | 38 | 100 | 28 | 75 |
| 4 | 45 | 120 | 33 | 85 |
| 5 | 61 | 150 | 43 | 110 |
| 6 | 79 | 180 | 55 | 130 |
| 8 | 120 | 230 | 82 | 160 |
| 10 | 170 | 310 | 110 | 210 |
| 12 | 230 | 380 | 150 | 250 |
| 14 | 270 | 430 | 170 | 280 |
| 16 | 340 | 510 | 220 | 320 |
| 18 | 430 | 590 | 270 | 370 |
| 20 | 520 | 690 | 320 | 430 |
| 22 | 620 | 780 | 380 | 480 |
| 24 | 730 | 900 | 450 | 550 |
| 26 | 850 | 1030 | 520 | 620 |
| 28 | 980 | 1160 | 590 | 700 |
| 30 | 1110 | 1290 | 670 | 780 |

^① Based upon Sch. 40 pipe.

^② Consult factory for higher flow rates.

4.4 Specifications

4.4.1 Model F10 Actuating Flow Rates (cont.)

Water Service m³/h

Model F10 units may be adjusted in service to actuate within the minimum and maximum flow rates given below. A specific gravity correction factor is applied for liquids other than water (1.00 specific gravity).

| Pipe Line Size Inches ^① | Flow Increase (m ³ /h) | | Flow Decrease (m ³ /h) | |
|---------------------------------------|-----------------------------------|----------------------|-----------------------------------|---------|
| | Minimum | Maximum ^② | Minimum | Maximum |
| 2 | 4.8 | 14.3 | 3.6 | 10.9 |
| 2½ | 5.2 | 16.8 | 4.5 | 12.7 |
| 3 | 7.3 | 20.0 | 5.4 | 14.8 |
| 3½ | 8.6 | 22.7 | 6.4 | 17.0 |
| 4 | 10.2 | 27.2 | 7.5 | 19.3 |
| 5 | 13.8 | 34.1 | 9.8 | 25.0 |
| 6 | 17.9 | 40.9 | 12.5 | 29.5 |
| 8 | 27.2 | 52.2 | 18.6 | 36.3 |
| 10 | 38.6 | 70.4 | 25.0 | 47.7 |
| 12 | 52.2 | 86.3 | 34.1 | 56.8 |
| 14 | 61.3 | 97.6 | 38.6 | 63.6 |
| 16 | 77.2 | 115.8 | 49.9 | 72.6 |
| 18 | 97.6 | 133.8 | 61.3 | 84.0 |
| 20 | 118.0 | 156.6 | 72.6 | 97.6 |
| 22 | 140.7 | 177.1 | 86.3 | 109.0 |
| 24 | 165.7 | 204.3 | 102.2 | 124.9 |
| 26 | 193.0 | 233.8 | 118.0 | 140.7 |
| 28 | 222.5 | 263.3 | 133.9 | 158.9 |
| 30 | 252.0 | 292.8 | 152.1 | 177.1 |

^① Based upon Sch. 40 pipe.

^② For higher flow rates consult factory.

4.4.2 Model F50 Actuating Flow Rates

| Pipe Size (NPT) | Actuating Flow Rate, GPM Water Flow Increasing and Decreasing Rate | | | | | |
|-----------------|--|----------|----------|----------|-----------|-----------|
| | A | B | C | D | E | F |
| ¾" | Not Available | 1.1 inc. | 1.6 inc. | 2.3 inc. | 3.4 inc. | 4.9 inc. |
| | | 0.8 dec. | 1.2 dec. | 1.8 dec. | 2.6 dec. | 3.7 dec. |
| 1" | 1.0 inc. | 1.7 inc. | 2.5 inc. | 3.7 inc. | 5.5 inc. | 7.1 inc. |
| | 0.8 dec. | 1.4 dec. | 2.1 dec. | 3.0 dec. | 4.5 dec. | 5.8 dec. |
| 1½" | 1.3 inc. | 2.7 inc. | 4.7 inc. | 7.6 inc. | 12.3 inc. | 21.1 inc. |
| | 1.1 dec. | 2.3 dec. | 4.0 dec. | 6.5 dec. | 10.5 dec. | 17.9 dec. |
| 2" | 1.9 inc. | 3.1 inc. | 5.1 inc. | 8.4 inc. | 14.3 inc. | 24.8 inc. |
| | 1.6 dec. | 2.7 dec. | 4.3 dec. | 7.1 dec. | 12.1 dec. | 21.0 dec. |

4.4.3 Model F10 Dimensional Specifications

NOTE: For proper performance, a straight pipe run of 12 pipe diameters upstream and 3 pipe diameters downstream of the switch is recommended.

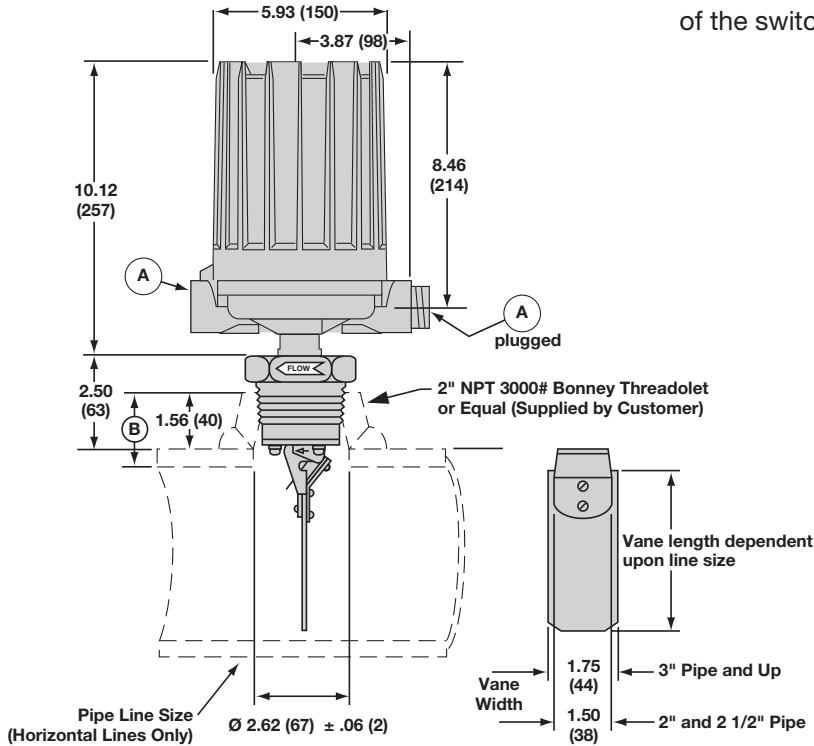

| Line Size | Dim. B Max. | Equivalent Max. Wall Schedule |
|-----------|-------------|-------------------------------|
| 2" | 1.81 (46) | 80 |
| 2½" | 1.94 (49) | 160 |
| 3" | 1.88 (48) | 80 |
| 3½" | 1.88 (48) | 80 |
| 4" | 2.00 (51) | 120 |
| 5" | 2.06 (52) | 120 |
| 6" | 2.12 (54) | 120 |
| 8" | 2.19 (56) | 100 |
| Over 8" | 2.31 (59) | — |

F10 with 2" NPT Connection

| Conduit Connections A |
|-----------------------------|
| Electrical Switches: 1" NPT |
| Pneumatic Switches: ¼" NPT |

Note: Allow the following for overhead clearance for cover removal:
 Carbon Steel (pneumatic) — 8.00 (203)
 Aluminum — 10.00 (254)

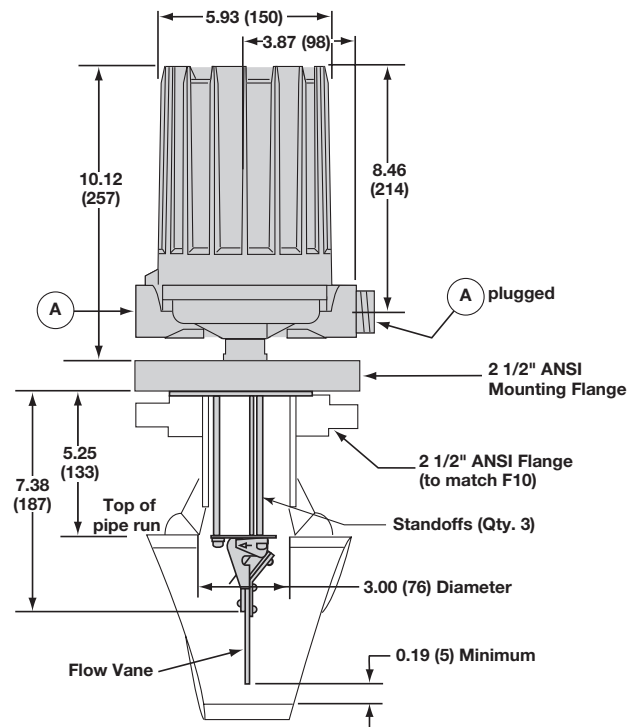

F10 with Flanged Connection

4.4.4 Model F50 Dimensional Specifications

Inches (mm)

NOTE:

1. For proper performance, a straight pipe run of 12 pipe diameters upstream and 3 pipe diameters downstream of the switch is recommended.
2. For NEMA 4X/7/9 allow 8.00 (203) overhead clearance for cover removal.

| Outline Dimensions | | | | |
|-----------------------------|---------------|---------------|---------------|--------------|
| Housing | A | B | C* | D |
| Aluminum | 5.93 (151) | 4.29 (108) | 9.75 (247) | 3.60 (91) |
| Carbon Steel (pneumatic) | 4.70 (119) | 5.00 (127) | 8.44 (214) | 3.44 (87) |

* This dimension increases by 2.19" (55) when the unit is supplied with an HS hermetically sealed switch with terminal block

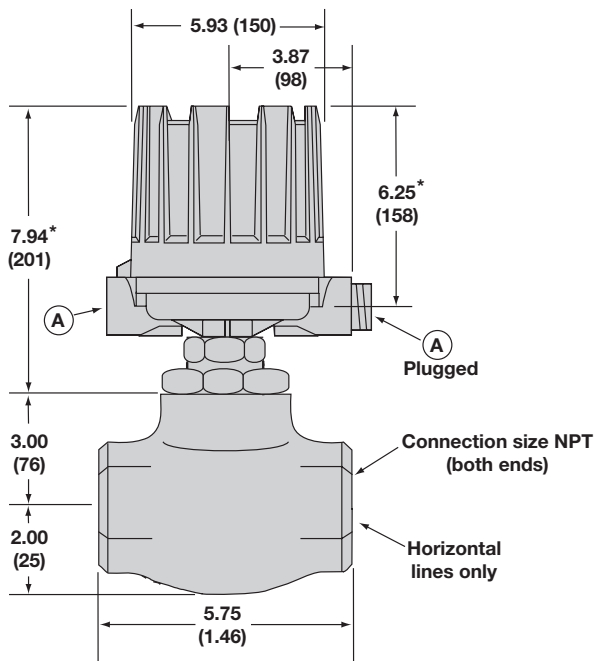

F50 Flow Switch with 1½" or 2" NPT Internal Pipe, Bronze or Stainless Steel Body

| Conduit Connections E |
|-----------------------------|
| Electrical Switches: 1" NPT |
| Pneumatic Switches: ¼" NPT |

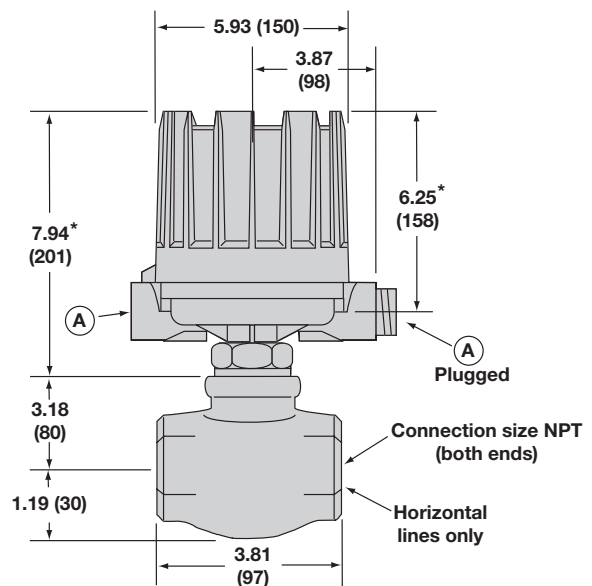

F50 Flow Switch with ¾" or 1" NPT Internal Pipe, Bronze or Stainless Steel Body

| Outline Dimensions | | | | |
|-----------------------------|---------------|---------------|----------------|---------------|
| Housing | A | B | C* | D |
| Aluminum | 5.93 (151) | 4.29 (108) | 10.75 (273) | 4.60 (116) |
| Carbon Steel (pneumatic) | 4.70 (119) | 5.00 (127) | 9.44 (240) | 4.44 (113) |

* This dimension increases by 2.19" (55) when the unit is supplied with an HS hermetically sealed switch with terminal block

4.5 Replacement Parts

4.5.1 Model F10

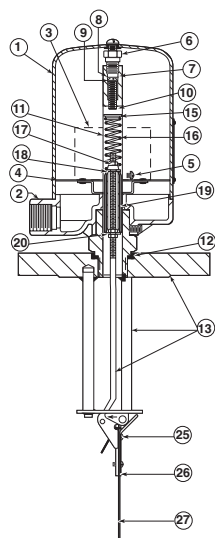

Figure 11 — F10 with Flange Connection

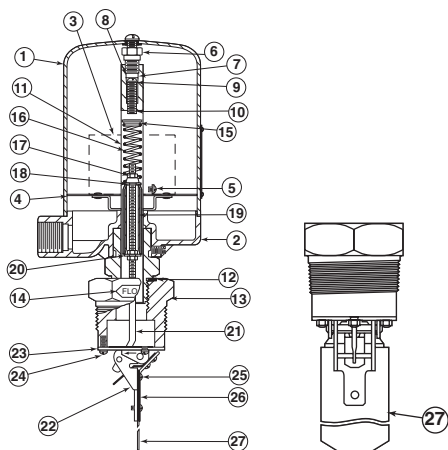

Figure 12 — F10 with Threaded Connection

4.5.1.1 Model F10 Parts Identification

| | |
|----|---|
| 1 | Housing cover |
| 2 | Housing base |
| 3 | Switch mechanisms |
| 4 | Baffle plate |
| 5 | 6-32 round head screw |
| 6 | 1/4-20 NPT plug |
| 7 | Safety retainer |
| 8 | Washer |
| 9 | O-ring |
| 10 | Adjustment screw |
| 11 | Enclosing tube |
| 12 | Enclosing tube gasket |
| 13 | Body bushing or stem, cam follower & flange assy. |
| 14 | Flow arrow |
| 15 | Upper spring guide |
| 16 | Range spring |
| 17 | 10-32 hex nut |
| 18 | Lower spring guide |
| 19 | Attraction sleeve |
| 20 | Washer |
| 21 | Stem assembly |
| 22 | Cam assembly |
| 23 | No. 8 lock washer |
| 24 | 8-32 fillister head screw |
| 25 | 8-32 round head screw |
| 26 | Small vane |
| 27 | Large vane |

4.5.1.2 Model F10 Switch and Housing Refere

| | Series Type | Bulletin # |
|--------------------------|-------------|------------|
| Dry contact | B, C, D | 42-683 |
| Hermetically sealed | HS | 42-694 |
| Bleed type pneumatic | J | 42-685 |
| Non-bleed type pneumatic | K | 42-686 |

IMPORTANT:

When ordering replacement parts, please specify:

- A. Model and serial number of control.
- B. Name and number of replacement part.

4.5.1 Model F10 (continued)

4.5.1.3 Model F10 Threaded Mounting

| | Carbon Steel | 304 SS | 316 SS |
|---|--|--------------|--------------|
| Housing cover | See Switch and housing reference on previous page | | |
| Housing base | See Switch and housing reference on previous page | | |
| Switch mechanism | See Switch and housing reference on previous page | | |
| Baffle plate | 036-5303-001 | | |
| 6-32 round head screw | 010-1409-005 | | |
| Enclosing tube kit: includes items 6 through 11 | 089-5912-001 | 089-5913-001 | 089-5914-001 |
| Enclosing tube gasket | 012-1204-001 | | |
| Body bushing | 089-5704-001 | 089-5705-001 | 089-5706-001 |
| Flow arrow | 005-9822-001 | | |
| Stem assembly kit: includes items 14 through 24 | 089-5541-001 | | 089-5542-001 |
| Vane kit: includes items 25 through 27 | 089-6703-001 — Consult factory for pipe runs over 8" | | |

4.5.1.4 Model F10 Flanged Mounting

| | Forged Steel | 304 SS | 316 SS | |
|---|---|--------------|--------------|--------------|
| Housing cover | See Switch and housing reference on previous page | | | |
| Housing base | See Switch and housing reference on previous page | | | |
| Switch mechanism | See Switch and housing reference on previous page | | | |
| Baffle plate | 036-5303-001 | | | |
| 6-32 round head screw | 010-1409-005 | | | |
| Enclosing tube kit: includes items 6 through 11 | 089-5928-001 | 089-5929-001 | 089-5930-001 | |
| Enclosing tube gasket | 012-1204-001 | | | |
| Stem, cam follower, and flange assy. | 150 lb. | 032-7203-001 | 032-7204-001 | 032-7205-001 |
| | 300 lb. | 032-7203-002 | 032-7204-002 | 032-7205-002 |
| | 600 lb. | 032-7203-003 | 032-7204-003 | 032-7205-003 |
| Attraction sleeve and spring kit: includes items 14 through 20 | 089-5544-001 | | 089-5545-001 | |
| Vane kit: includes items 25 through 27 | 089-6703-001 — Consult factory for pipe sizes over 8" | | | |

4.5.2 Model F50

4.5.2.1 Model F50 Parts Identification

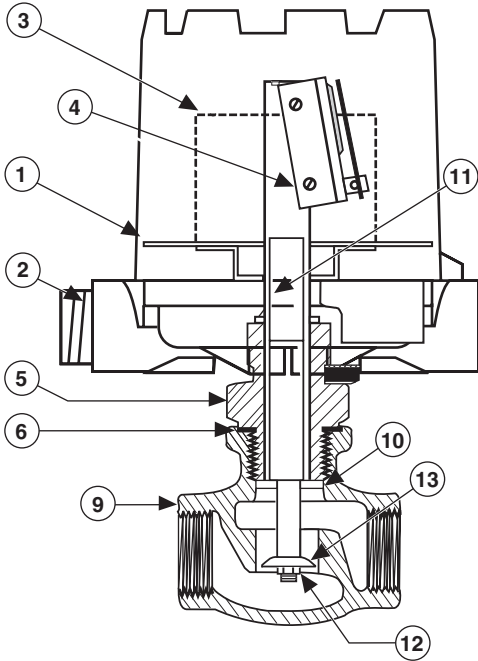

| | |
|----|--------------------------|
| 1 | Housing cover |
| 2 | Housing base |
| 3 | Switch mechanism |
| 4 | Switch |
| 5 | Enclosing tube |
| 6 | E-tube gasket |
| 7 | O-ring (not shown) |
| 8 | Body adaptor (not shown) |
| 9 | Threaded body |
| 10 | Flow piston stop |
| 11 | Flow piston assy ① |
| 12 | Lock nut ② |
| 13 | Flow disc ③ |

- ① Highly corrosive applications use piston assembly with sheathed attraction sleeve. Consult local representative for ordering assistance.
- ② Use insoluble adhesive on nut when attaching new flow disc.
- ③ When actuated flow rate is critical, the entire control must be returned to the factory for replacement and recalibration of flow disc.

4.5.2.2 Model F50 Switch and Housing Reference

| | Series Type | Bulletin # |
|--------------------------|-------------|------------|
| Dry contact | B, C, D | 42-683 |
| Hermetically sealed | F | 42-683 |
| Hermetically sealed | HS | 42-694 |
| Bleed type pneumatic | J | 42-685 |
| Non-bleed type pneumatic | K | 42-686 |

IMPORTANT:

When ordering replacement parts, please specify:

- A. Model and serial number of control.
- B. Name and number of replacement part.

4.5.2 Model F50 (continued)

4.5.2.3 Model F50 Bronze Body Replacement Parts

| | ¾" | 1" | 1½" | 2" |
|-----------------------|---|--------------|--------------|--------------|
| Housing cover | See Switch and housing reference on previous page | | | |
| Housing base | See Switch and housing reference on previous page | | | |
| Switch mechanism | See Switch and housing reference on previous page | | | |
| Switch | See Switch and housing reference on previous page | | | |
| Enclosing tube | Z32-6325-002 | | | |
| Enclosing tube gasket | 012-1204-001 | | | |
| O-ring | Not required | | 012-1204-036 | |
| Body adaptor | Not required | | 004-0481-001 | |
| Threaded body | 002-5703-003 | 002-5703-004 | 002-5705-003 | 002-5705-004 |
| Flow piston stop | 005-5420-121 | | Not required | |
| Flow piston assembly | 032-7127-001 | 032-7127-003 | 032-7127-002 | |
| Lock nut ① | 010-2107-002 | 010-2107-003 | | |
| Flow disc ② | Specify model number and serial number | | | |

4.5.2.4 Model F50 Stainless Steel Body Replacement Parts

| | ¾" | 1" | 1½" | 2" |
|-----------------------|---|--------------|--------------|--------------|
| Housing cover | See Switch and housing reference on previous page | | | |
| Housing base | See Switch and housing reference on previous page | | | |
| Switch mechanism | See Switch and housing reference on previous page | | | |
| Switch | See Switch and housing reference on previous page | | | |
| Enclosing tube | Z32-6325-002 | | | |
| Enclosing tube gasket | 012-1204-001 | | | |
| O-ring | Not required | | 012-1204-036 | |
| Body adaptor | Not required | | 004-0481-001 | |
| Threaded body | 002-5703-001 | 002-5703-002 | 002-5705-001 | 002-5705-002 |
| Flow piston stop | 005-5420-121 | | Not required | |
| Flow piston assembly | 032-7108-001 | 032-7109-001 | 032-7109-002 | |
| Lock nut ① | 010-2107-002 | 010-2107-003 | | |
| Flow disc ② | Specify model number and serial number | | | |

① Use insoluble adhesive on nut when attaching new flow disc.

② When actuation flow rate is critical, the entire control must be returned to the factory for replacement and recalibration of flow disc.

4.6 Model Numbers

4.6.1 Model F10

MODEL NUMBER CODE

| | Mounting Connection | Trim | Magnetic Sleeve | Pressure |
|-------|---------------------|-----------------------------|---------------------|--|
| F10-1 | Carbon steel | 304 and 316 stainless steel | 316 stainless steel | 1000 psig @ +450 °F (69 bar @ +232 °C) |
| F10-3 | 304 stainless steel | 304 and 316 stainless steel | 316 stainless steel | 1000 psig @ +450 °F (69 bar @ +232 °C) |
| F10-4 | 316 stainless steel | 316 stainless steel | 316 stainless steel | 1000 psig @ +450 °F (69 bar @ +232 °C) |

On flanged models, standoffs are carbon steel with Model F10-1 and 316 stainless steel on Models F10-3 and F10-4. Consult factory for Steam applications.

MODEL NUMBER CODE

| Connection Type | Vane Sized for Flow Line | | | | |
|--|--------------------------|-----|-----|-----|-----|
| | 2" | 4" | 6" | 8" | 10" |
| 2" NPT | D22 | D24 | D26 | D28 | D20 |
| 2 1/2" 150 lb. ANSI raised face flange | n/a | E54 | E56 | E58 | E50 |
| 2 1/2" 300 lb. ANSI raised face flange | n/a | E64 | E66 | E68 | E60 |
| 2 1/2" 600 lb. ANSI raised face flange | n/a | E74 | E76 | E78 | E70 |

Consult factory for flow lines above 10" or larger flange sizes and installations over Sch. 160 when using flanged Model F10.

PNEUMATIC SWITCH MECHANISM AND ENCLOSURE

| Switch Description | Maximum Supply Pressure | | Maximum Process Temperature | | Bleed Orifice Diameter | | NEMA 1 |
|------------------------|-------------------------|-----|-----------------------------|------|------------------------|-----|--------|
| | psig | bar | ° F | ° C | inches | mm | |
| Series J Bleed Type | 100 | 7 | +400 | +204 | 0.063 | 1.6 | JGF |
| | 60 | 4 | +400 | +204 | 0.094 | 2.4 | JHF |
| | 60 | 4 | +400 | +204 | 0.055 | 1.4 | JJF |
| Series K Non-Bleed | 100 | 7 | +400 | +204 | — | — | KOF |
| | 40 | 3 | +400 | +204 | — | — | — |

ELECTRIC SWITCH MECHANISM AND ENCLOSURE

| Switch Description | Maximum Process Temperature °F (°C) ① | One Set Point | Aluminum Enclosure ② ③ | | |
|--|---------------------------------------|---------------|------------------------------|---------------------------|-------------------|
| | | | FM (US/CA) Groups C&D 1" NPT | FM (US/CA) Group B 1" NPT | ATEX IECEx 1" NPT |
| Series B snap | +250 (+121) | SPDT DPDT | BKB BNB | BKK BNK | BC9 BF9 |
| Series C snap | +450 (+232) | SPDT DPDT | CKB CNB | CKK CNK | CC9 CF9 |
| Series D snap for DC current applications | +250 (+121) | SPDT DPDT | DKB DNB | DKK DNK | DC9 DF9 |
| Series HS 5 amp hermetically sealed snap with wiring leads | +450 (+232) | SPDT DPDT | HMJ HMS | HMK HMT | n/a n/a |
| Series HS 5 amp hermetically sealed snap with terminal block | +450 (+232) | SPDT DPDT | HM3 HM7 | HM4 HM8 | HA9 HB9 |

① Process temperatures based on +100 °F (+38 °C) ambient.

② Uncontrolled housing heater or drain available in NEMA 4X/7/9 enclosures.

③ Consult factory for NEMA 4X/7/9 cast iron housings.



4.6.2 Model F50

MODEL NUMBER CODE

| | Body | Trim | Magnetic Sleeve | Pressure Ratings |
|-------|---------------------|----------------------------|----------------------------|--|
| F50-1 | Bronze | 300 series stainless steel | 400 series stainless steel | 1100 psi @ +100 °F (75.8 bar @ 38 °C) 750 psi @ +500 °F maximum (51.7 bar @ 260 °C maximum) |
| F50-4 | 316 stainless steel | 316 stainless steel | 316 stainless steel | 1150 psi @ +100 °F (79.2 bar @ 38 °C) 900 psi @ +750 °F maximum (62 bar @ 399 °C maximum) |

| | |
|-----------|--|
| A2 | ¾" pipe size with ¾" NPT connections |
| B2 | 1" pipe size with 1" NPT connections |
| C2 | 1½" pipe size with 1½" NPT connections |
| D2 | 2" pipe size with 2" NPT connections |

ACTUATING FLOW RATE

| Pipe size | Actuating Flow Rate, GPM Water Flow, Increasing and Decreasing Rate | | | | | |
|-----------|---|----------------------------------|----------------------------------|----------------------------------|------------------------------------|------------------------------------|
| | A | B | C | D | E | F |
| ¾" NPT | n/a n/a | 1.1 increasing 0.8 decreasing | 1.6 increasing 1.2 decreasing | 2.3 increasing 1.8 decreasing | 3.4 increasing 2.6 decreasing | 4.9 increasing 3.7 decreasing |
| 1" NPT | 1.0 increasing 0.8 decreasing | 1.7 increasing 1.4 decreasing | 2.5 increasing 2.1 decreasing | 3.7 increasing 3.0 decreasing | 5.5 increasing 4.5 decreasing | 7.1 increasing 5.8 decreasing |
| 1½" NPT | 1.3 increasing 1.1 decreasing | 2.7 increasing 2.3 decreasing | 4.7 increasing 4.0 decreasing | 7.6 increasing 6.5 decreasing | 12.3 increasing 10.3 decreasing | 21.1 increasing 17.9 decreasing |
| 2" NPT | 1.9 increasing 1.6 decreasing | 3.1 increasing 2.7 decreasing | 5.1 increasing 4.3 decreasing | 8.4 increasing 7.1 decreasing | 14.3 increasing 12.1 decreasing | 24.8 increasing 21.0 decreasing |

PNEUMATIC SWITCH MECHANISM AND ENCLOSURE

| Switch Description | Process Temp. °F (°C) | Max. Maximum Supply Pressure ① ② | Bleed Orifice Diameter | Body Material | Pipe Size (NPT) | Flow Rate | NEMA 1 |
|-------------------------|-----------------------|-------------------------------------|------------------------|---------------|-----------------|---------------------|--------|
| Series J bleed type | +550 (+288) | 100 psig (7 bar) | 0.063" (1.6 mm) | Bronze | ¾" or 1" | A thru F | JDG |
| | | | | | 1½" or 2" | A thru D E and F | |
| | | 60 psig (4 bar) | 0.094" (2.4 mm) | Bronze | ¾" thru 2" | A thru F | JDE |
| | | | | | 1½" or 2" | A thru D E and F | |
| Series K non-bleed type | +550 (+288) | 100 psig (7 bar) | n/a | Bronze | 1½" or 2" | E and F | KOE |
| | | | | | Stainless Steel | ¾" thru 2" | |
| | | 40 psig (3 bar) | n/a | Bronze | ¾" thru 1" | A thru F | KOG |
| | | | | | 1½" or 2" | A thru D | |

① Process temperatures based on -40° to +160 °F (-40° to +71 °C).

② Bronze models are rated to a maximum process temperature of +500 °F (+260 °C). Stainless steel models are limited to the maximum temperature of the selected switch mechanism.

③ On steam applications, temperature down-rated to +400 °F (+204 °C) process at +100 °F (+40 °C) ambient.

④ On models with bronze bodies ¾" or 1" NPT pipe sizes, consult factory for HS switches.



4.6.2 Model F50 (continued)

ELECTRIC SWITCH MECHANISM AND ENCLOSURE

| Switch Description | Maximum Process Temperature Range °F (°C) ①② | One Set Point | Body Material | Pipe Size (NPT) | Flow Rate | Aluminum Enclosure | | |
|--|---|--------------------------------|---------------|-----------------|------------|------------------------------|---------------------------|-------------------|
| | | | | | | FM (US/CA) Groups C&D 1" NPT | FM (US/CA) Group B 1" NPT | ATEX/IECEX 1" NPT |
| Series B snap | -40 to +250 (-40 to +121) | SPDT | Bronze | ¾" or 1" | A thru F | BKP | BKT | BAC |
| | | | | 1½" or 2" | A thru D | | | |
| | | | E and F | BKQ | BKS | | | |
| | | Stainless Steel | ¾" thru 2" | | | A thru F | | |
| | | DPDT | Bronze | | | ¾" or 1" | A thru F | BNP |
| | | | | 1½" or 2" | A thru D | | | |
| E and F | BNQ | | BNS | BB9 | | | | |
| Stainless Steel | | ¾" thru 2" | | | A thru F | | | |
| Series C snap | | -40 to +450 (-40 to +232) | | | SPDT | Bronze | ¾" or 1" | A thru F |
| | 1½" or 2" | | A thru D | | | | | |
| | E and F | | CKQ | CKS | | CA9 | | |
| | Stainless Steel | | | | ¾" thru 2" | | A thru F | |
| | DPDT | | | | Bronze | | ¾" or 1" | A thru F |
| | | | 1½" or 2" | A thru D | | | | |
| E and F | | CNQ | CNS | CB9 | | | | |
| Stainless Steel | ¾" thru 2" | | | | A thru F | | | |
| Series D snap for DC current applications | -40 to +250 (-40 to +121) | | | | SPDT | Stainless Steel | ¾" thru 2" | A thru F |
| | | DPDT | DNQ | DNS | DB9 | | | |
| Series F snap | -40 to +750 (-40 to +399) | SPDT | Bronze | ¾" or 1" | A thru F | FKP | FKT | FAC |
| | | | | 1½" or 2" | A thru D | | | |
| | | | E and F | FKQ | FKS | | | |
| | | Stainless Steel | ¾" thru 2" | | | A thru F | | |
| | | DPDT | Bronze | | | ¾" or 1" | A thru F | FNP |
| | | | | 1½" or 2" | A thru D | | | |
| E and F | FNQ | | FNS | FB9 | | | | |
| Stainless Steel | | ¾" thru 2" | | | A thru F | | | |
| Series HS snap 5 amp hermetically sealed w/ wiring leads | | -50 to +550 (-46 to +288) ③ | | | SPDT | Bronze | 1½" thru 2" ④ | A thru F |
| | DPDT | | Bronze | 1½" thru 2" ④ | A thru F | HMF | HET | n/a |
| Series HS snap 5 amp hermetically sealed w/ terminal block | -50 to +550 (-46 to +288) ③ | SPDT | Bronze | 1½" thru 2" ④ | A thru F | HM3 | HM4 | HA9 |
| | | DPDT | Bronze | 1½" thru 2" ④ | A thru F | HM7 | HM8 | HB9 |

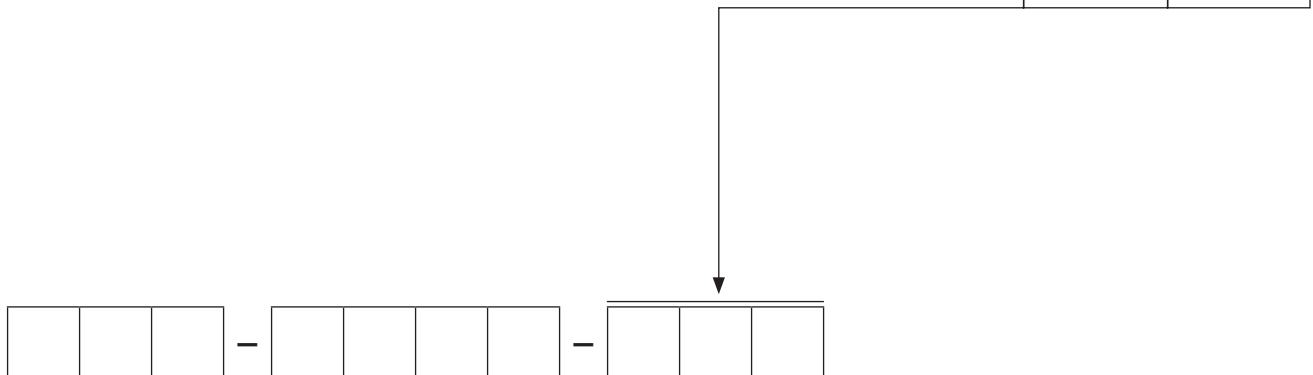

Service Policy

Owners of AMETEK LMS may request the return of a control or any part of a control for complete rebuilding or replacement. They will be rebuilt or replaced promptly. Controls returned under our service policy must be returned by Prepaid transportation. AMETEK LMS will repair or replace the control at no cost to the purchaser (or owner) other than transportation if:

1. Returned within the warranty period; and
2. The factory inspection finds the cause of the claim to be covered under the warranty.

If the trouble is the result of conditions beyond our control; or, is NOT covered by the warranty, there will be charges for labor and the parts required to rebuild or replace the equipment.

In some cases it may be expedient to ship replacement parts; or, in extreme cases a complete new control, to replace the original equipment before it is returned. If this is desired, notify the factory of both the model and serial numbers of the control to be replaced. In such cases, credit for the materials returned will be determined on the basis of the applicability of our warranty.

No claims for misapplication, labor, direct or consequential damage will be allowed.

Return Material Procedure

So that we may efficiently process any materials that are returned, it is essential that a "Return Material Authorization" (RMA) number be obtained from the factory, prior to the material's return. This is available through an AMETEK LMS local representative or by contacting the factory. Please supply the following information:

1. Company Name
2. Description of Material
3. Serial Number
4. Reason for Return
5. Application

Any unit that was used in a process must be properly cleaned in accordance with OSHA standards, before it is returned to the factory.

A Material Safety Data Sheet (MSDS) must accompany material that was used in any media.

All shipments returned to the factory must be by prepaid transportation.

All replacements will be shipped F.O.B. factory.

