

E4 MODULELEVEL®

HART® Installation and Operating Manual for Model E4 Modulelevel®

Liquid Level Displacer Transmitter

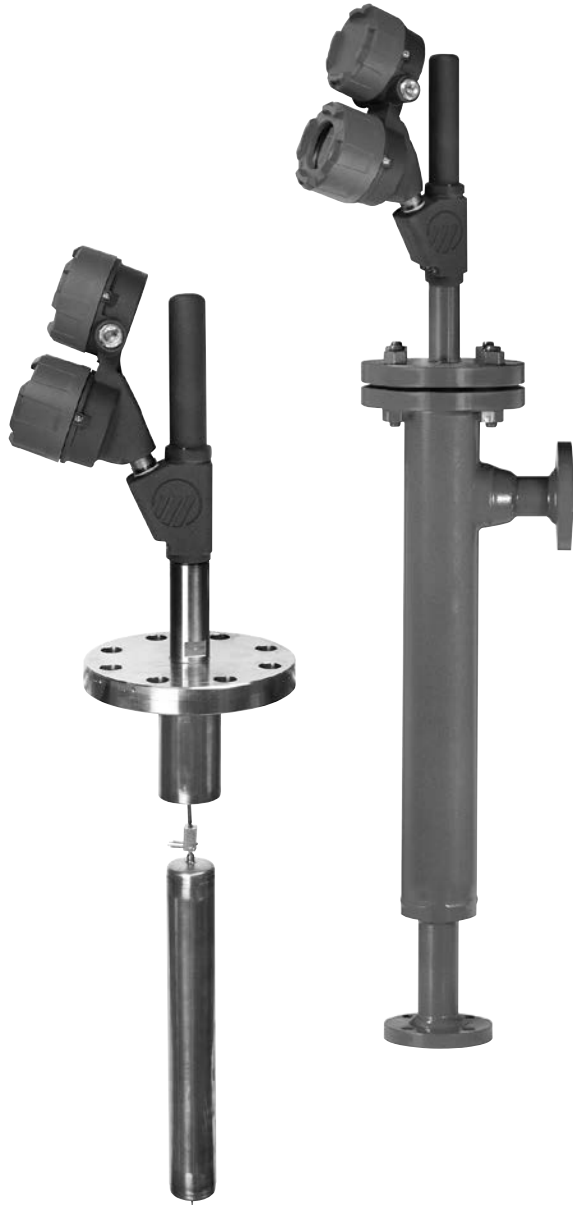

Read this Manual Before Installing

This manual provides information on the E4 Modulelevel® Electronic Transmitters. It is important that all instructions are read carefully and followed in sequence. Detailed installation, wiring and calibration instructions are included in this manual.

If this equipment is used in a manner not specified by this manufacturer, the protection provided by the equipment may be impaired.

Conventions Used in this Manual

Certain conventions are used in this manual to convey specific types of information. General technical material, support data, and safety information are presented in narrative form. The following styles are used for notes, cautions, and warnings.

NOTES

Notes contain information that augments or clarifies an operating step. Notes do not normally contain actions. They follow the procedural steps to which they refer.

Cautions

Cautions alert the technician to special conditions that could injure personnel, damage equipment, or reduce a component's mechanical integrity. Cautions are also used to alert the technician to unsafe practices or the need for special protective equipment or specific materials. In this manual, a caution box indicates a potentially hazardous situation which, if not avoided, may result in minor or moderate injury.

WARNINGS

Warnings identify potentially dangerous situations or serious hazards. In this manual, a warning indicates an imminently hazardous situation which, if not avoided, could result in serious injury or death.

Safety Messages

Follow all standard industry procedures for servicing electrical and computer equipment when working with or around high voltage. Always shut off the power supply before touching any components.

Electrical components are sensitive to electrostatic discharge. To prevent equipment damage, observe safety procedures when working with electrostatic sensitive components.

WARNING! Explosion hazard. Do not connect or disconnect equipment unless power has been switched off or the area is known to be non-hazardous.

Low Voltage Directive

For use in Installation Category I, Pollution Degree 2. If equipment is used in a manner not specified by manufacturer, protection provided by equipment may be impaired.

Warranty

All AMETEK LMS electronic level and flow controls are warranted free of defects in materials or workmanship for eighteen months from the date of original factory shipment.

If returned within the warranty period; and, upon factory inspection of the control, the cause of the claim is determined to be covered under the warranty; then, AMETEK LMS will repair or replace the control at no cost to the purchaser (or owner) other than transportation.

AMETEK LMS shall not be liable for misapplication, labor claims, direct or consequential damage or expense arising from the installation or use of equipment. There are no other warranties expressed or implied, except special written warranties covering some AMETEK LMS products.

Quality Assurance

The quality assurance system in place at AMETEK LMS guarantees the highest level of quality throughout the company. Magnetrol is committed to providing full customer satisfaction both in quality products and quality service.

The AMETEK LMS quality assurance system is certified to ISO 9001, affirming our commitment to internationally recognized quality management standards and continuous improvement.

Copyright © 2026 AMETEK Magnetrol USA, LLC

Performance specifications are effective with date of issue and are subject to change without notice. AMETEK LMS reserves the right to make changes to the product described in this manual at any time without notice. AMETEK LMS makes no warranty with respect to the accuracy of the information in this manual.

E4 Modulelevel® Displacer Level Transmitter

Table of Contents

1.0 QuickStart Installation

1.1 Getting Started	4
1.1.1 Equipment and Tools	4
1.1.2 Configuration Information	4
1.2 QuickStart Mounting	4
1.2.1 Tank Top (E4M – no chamber)	4
1.2.2 External Chamber (E4M – with chamber included)	5
1.3 QuickStart Wiring	5
1.4 QuickStart Configuration	6

2.0 Complete Installation

2.1 Unpacking	8
2.2 Electrostatic Discharge (ESD) Handling Procedure	8
2.3 Before You Begin	9
2.3.1 Site Preparation	9
2.3.2 Equipment and Tools	9
2.3.3 Operational Considerations	9
2.4 Mounting	10
2.4.1 Tank Top Installation (E4M–no chamber)	10
2.4.2 E4M – with chamber included	11
2.4.3 E4T – Transmitter Replacement Only	12
2.4.3.1 Removal of the EZ, ES, ES II or E3 Transmitter Head	12
2.4.3.2 Installation of the E4 Modulelevel Transmitter Head	13
2.5 Wiring	13
2.5.1 General Purpose or Non-Incendive (Cl. I, Div. 2)	14
2.5.2 Intrinsically Safe	15
2.5.3 Explosion Proof / Flameproof	15
2.6 Configuration	17
2.6.1 Menu Traversal and Data Entry	17
2.6.1.1 Navigating the Menu	17
2.6.1.2 Data Selection	18
2.6.1.3 Entering Numeric Data Using Digit Entry	18
2.6.1.4 Entering Numeric Data Using Increment/Decrement	19
2.6.1.5 Entering Character Data	19
2.6.2 Password Protection	20
2.6.3 Calibration Defaults	20
2.6.4 E4 Modulelevel Menu: Step-By-Step Procedure	21

2.6.5 E4 Modulelevel Configuration Menu – Device Setup	22
2.6.5.1 Dry and Wet User Calibration Procedures	24
2.7 Configuration Using HART	25
2.7.1 Connections	25
2.7.2 HART Communicator Display	25
2.7.3 HART Revision Table	25
2.7.4 HART Menu – Model E4	25

3.0 Reference Information

3.1 Description	28
3.2 Theory of Operation	28
3.2.1 Displacer/Range Spring	28
3.2.2 LVDT	28
3.2.3 Interface	29
3.2.4 Specific Gravity	29
3.3 Troubleshooting and Diagnostics	29
3.3.1 Diagnostics (Namur NE 107)	30
3.3.2 Diagnostic Indication Simulation	31
3.3.3 Diagnostic Indicator Table	32
3.3.4 Troubleshooting System Problems	33
3.3.5 Checking the LVDT Winding Resistance	34
3.4 Agency Approvals	34
3.4.1 Special Conditions of Use	35
3.4.2 Agency Drawing	36
3.5 Parts	37
3.5.1 Replacement Transmitter Head Parts	37
3.5.3 Mechanical Replacement Parts	37
3.6 Specifications	39
3.6.1 Functional	39
3.6.2 Performance – Level	40
3.6.3 Performance – Interface Level & Specific Gravity	40
3.6.4 Loop Resistance	41
3.6.5 Transmitter Terminal Voltage	41
3.6.6 Physical – E4 Modulelevel Dimensions	42
3.6.7 Physical – E4 Chamber Dimensions	43
3.7 Model Numbers	44
3.7.1 E4 Transmitter with Displacer Assembly	44
3.7.2 E4 Transmitter Only	46
3.7.3 E4 Connecting Cable	47

1.0 QuickStart Installation

1.1 Getting Started

1.1.1 Equipment and Tools

No special equipment or tools are required to install E4 Modulelevel®. The following items are recommended:

- Wrenches, flange gaskets and flange bolting appropriate for process connection(s)
- Flat-blade screwdriver
- Level
- 1/8" Allen wrench
- Power supply
- Digital multimeter
- 250 to 450 ohm resistor for HART communication

1.1.2 Configuration Information

Some key information is needed to configure the E4 Modulelevel transmitter. Complete the following operating parameters table before beginning configuration.

Display	Question	Answer
Level Units	What units of measurement will be used?	
Process SG	What is the actual SG of the process liquid at operating temperature?	
Operating Temp	What is the actual operating temperature?	
Level Offset	What is the desired level reading when the level is at the calibrated zero reference (typically bottom of the displacer)?	
Lower Range Value	What should the level reading be at the 4 mA set point?	
Upper Range Value	What should the level reading be at the 20 mA set point?	

1.2 QuickStart Mounting

NOTE: Confirm the style and process connection size/type of the E4 Modulelevel transmitter. Ensure it matches the requirements of the installation before continuing with the QuickStart installation.

1.2.1 Tank Top (E4M – no chamber)

1. If applicable, adjust and trim the displacer hanger cable assembly to the required length and mount it between the stem and displacer.

2. Using a level, verify that the vessel mounting flange is level in all directions within 3°.
3. Position the head flange gasket on the vessel flange and gently lower the displacer into the vessel. To prevent damage to the stem/spring assembly, avoid tipping the unit or, in any way, putting lateral forces on the stem.
4. Align the flanges and ensure that the gasket is seated properly.
5. Install the flange bolts and nuts and tighten alternating nuts in a star pattern. Flange bolting torque specifications are listed on page 10.

1.2.2 External Chamber (E4M - with chamber included)

1. Remove the shipping strap and wire assembly which secures the displacer in the chamber during shipment. This assembly must be removed through the bottom connection or drain.
2. Using a level, verify that the vessel mounting flanges are level in all directions within 3°.
3. Align the Modulelevel process connections with those on the vessel and attach accordingly, based upon the connection type. Appropriate gaskets and bolting will be required for flanged connections. Install the flange bolts and nuts and tighten alternating nuts in a star pattern. Flange bolting torque specifications are listed on page 10.

1.3 QuickStart Wiring

WARNING! Explosion hazard. Do not connect or disconnect equipment unless power has been switched off or the area is known to be non-hazardous.

NOTE: Ensure that the electrical wiring to the E4 transmitter is complete and in compliance with all regulations and codes.

1. Remove the cover of the upper wiring compartment of the transmitter.
2. Attach a conduit fitting and mount the conduit plug in the spare opening. Pull the power supply wire through the conduit fitting.
3. Connect an earth ground to the nearest green ground screw. See Figure 1. Use a minimum 18 AWG rated up to 85 °C.
4. Connect the positive supply wire to the (+) terminal and the negative supply wire to the (-) terminal. For Explosion Proof Installations, see *Wiring, Section 2.5.3*.
5. Replace the cover and tighten.

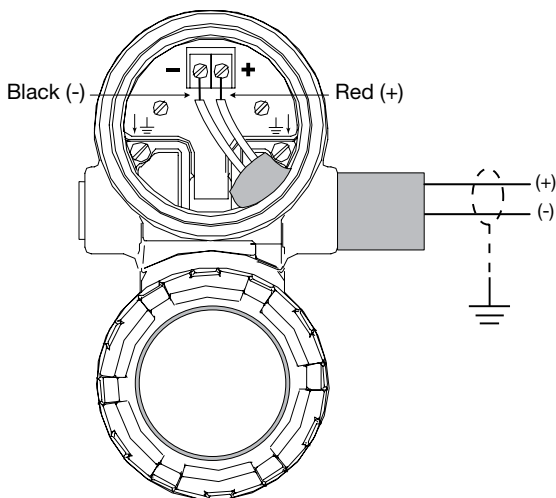

Figure 1
Integral Transmitter Wiring

1.4 QuickStart Configuration

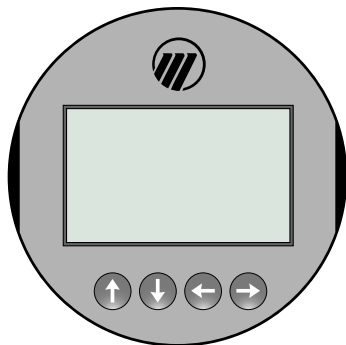

Figure 2
Transmitter Keypad & Display

The E4 Modulelevel transmitter comes configured with default values from the factory but can be reconfigured in the shop. The minimum configuration instructions required for using the QuickStart menu follow. Use the information from the operating parameters table in *Section 1.1.2* before proceeding with the configuration.

The QuickStart menu offers a very simple two screen overview showing the basic parameters required for typical 'Level' operation.

1. Apply power to the transmitter.

The graphic LCD display can be programmed to change every 2 seconds to show pertinent Measured Values on the Home Screen. For example: Level, Percent Range, and Loop Current can all be displayed on a rotating screen.

The LCD can also be programmed to always show just one of the Measured Variables at all times. For example: Level can be the only value displayed on the screen.

2. Remove the lower electronic compartment cover.
3. The push buttons offer multiple forms of functionality for menu navigation and data entry. (See *Section 2.6* for complete explanation.)

⇧ UP moves up through the menu or increases a displayed value.

⇩ DOWN moves down through the menu or decreases a displayed value.

⇐ BACK exits a branch of the menu or exits without accepting entered value.

⇨ ENTER enters a branch of the menu or accepts a displayed entry.

NOTE: Holding down ENTER when any menu or parameter is highlighted will show help text in reference to that item.

The default User Password = 0. (If a password is requested, enter it at that time.)

The following configuration entries are the minimum required for a QuickStart configuration.

4. Press any key at the Home Screen to access the Main Menu.
5. Press ⇨ ENTER with the DEVICE SETUP menu item highlighted.
6. Press ⇨ ENTER with the QUICK START menu item highlighted.

The QuickStart shows the basic parameters, with the present value of the highlighted parameter shown at the bottom of the screen.

One can now quickly and easily scroll through the QuickStart configuration items, changing those parameters required. Process SG and Operating Temp are the minimum required for configuration:

- Scroll to the parameter to be changed.
- Press \rightarrow ENTER at the highlighted parameter.
- Scroll to the desired option, then press \rightarrow ENTER.
- Scroll to next parameter or press \leftarrow BACK when finished to exit the QuickStart menu.

7. After making all of the necessary changes in the QuickStart menu, press the BACK button three times to return to the Home Screen.

8. The QuickStart configuration is complete. If properly configured, the Model E4 transmitter is measuring level and is ready for service.

The following parameters are available in the QuickStart menu if the default values are not satisfactory. Process SG and Operating Temp are the minimum required to configure for proper measurement.

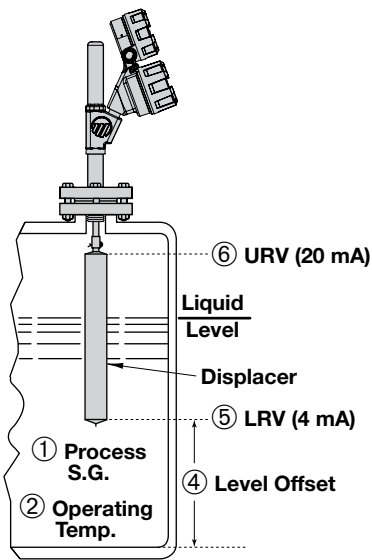

Figure 3
Tank Top Mounted Installation

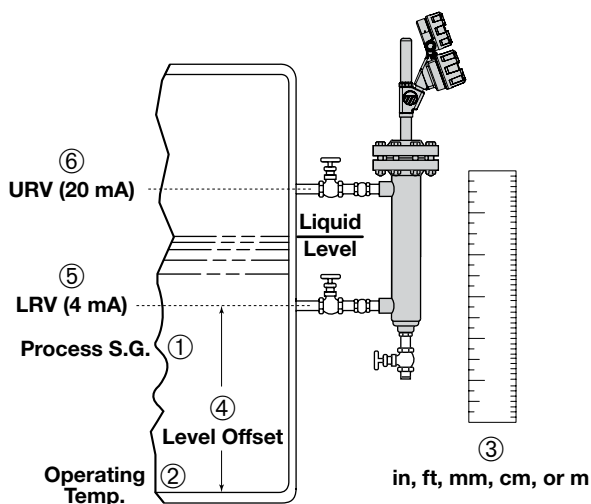

Figure 4
External Chamber Installation
Side-Side Process Connections

- | | | |
|---|-------------------|---|
| ① | Process SG | Enter the actual specific gravity of the process liquid at operating temperature (N/A for Interface or Density). |
| ② | Operating Temp | Enter the actual operating temperature of the process (temperature units automatically change with selected level units). |
| ③ | Level Units | Select the desired level units of measure (inches, feet, millimeters, centimeters, meters; default is inches). |
| ④ | Level Offset | Enter the desired level reading when level is at the calibrated zero reference (typically bottom of the displacer; default is 0). |
| ⑤ | Lower Range Value | Enter the level value (0%-point) for the 4 mA point (default is 0 for level and interface). |
| ⑥ | Upper Range Value | Enter the level value (100%-point) for the 20 mA point (default is full level range). |

2.0 Complete Installation

2.1 Unpacking

Unpack the instrument carefully. Take care not to bend the displacer stem or enclosing tube. Ensure all components have been removed from the packing material. Check all the contents against the packing slip and report any discrepancies to the factory.

Before proceeding with the installation, do the following:

- Inspect all components for damage. Report any damage to the carrier within 24 hours.
- On chambered units, remove the shipping strap and wire assembly holding the displacer in place. This assembly must be removed through the bottom chamber connection before start-up.

Caution: If reshipping to another location, the displacer must again be secured using the same strap and wire assembly.

- Check that the model number on the nameplate matches the packing slip and purchase order.
- Record the model and serial numbers for future reference when ordering parts.

Model Number

Serial Number

2.2 Electrostatic Discharge (ESD) Handling Procedure

Magnetrol® electronic instruments are manufactured to the highest quality standards. These instruments use electronic components which may be damaged by static electricity present in most work environments.

The following steps are recommended to reduce the risk of component failure due to electrostatic discharge.

- Ship and store circuit boards in anti-static bags. If an anti-static bag is not available, wrap the board in aluminum foil. Do not place boards on foam packing materials.
- Use a grounding wrist strap when installing and removing circuit boards. A grounded workstation is recommended.
- Handle circuit boards only by the edges. Do not touch components or connector pins.
- Ensure that all electrical connections are completely made and that none are partial or floating. Ground all equipment to a good, earth ground.



2.3 Before You Begin

2.3.1 Site Preparation

Each E4 Modulelevel transmitter is built to match the physical specifications of the required installation. Ensure that the process connection(s) on the vessel matches the Modulelevel process connection(s). See *Mounting, Section 2.4*.

Ensure that the wiring between the power supply and Modulelevel transmitter are complete and correct for the type of installation. See *Wiring, Section 2.5*.

When installing the Modulelevel transmitter in a general purpose or hazardous area, local, state and federal regulations and guidelines must be observed. See *Wiring, Section 2.5*.

2.3.2 Equipment and Tools

No special equipment or tools are required to install the Electronic Modulelevel. The following items are recommended:

- Wrenches, flange gaskets and flange bolting appropriate for process connection(s)
- Flat-blade screwdriver
- Level
- 1/8" Allen wrench
- Power supply
- Multimeter
- 250 to 450 ohm resistor for transmitters with HART communication

2.3.3 Operational Considerations

The Modulelevel transmitter should be located for easy access for service, configuration, and monitoring. There should be sufficient headroom to allow installation and removal of the transmitter head and, in cases of tank top configuration, the displacer. Special precautions should be made to prevent exposure to corrosive atmosphere, excessive vibration, shock, or physical damage.

The operating temperature range for the transmitter electronics is -40 to +176 °F (-40 to +80 °C). The operating temperature range for the digital display is -5 to +160 °F (-20 to +70 °C).

Caution: Operation of all buoyancy type level devices should be done in such a way as to minimize the action of dynamic forces on the float or displacer sensing element. Good practice for reducing the likelihood of damage to the control is to equalize pressure across the device very slowly.

2.4 Mounting

The E4 Modulelevel transmitter can be mounted to a tank using a variety of configurations and process connections. Generally, either a threaded, welded or flanged connection is used with an external cage. A flanged connection is always used on a tank top model. For information about the sizes and types of connections available, see *Section 3.7, Model Numbers*.

Ensure all mounting connections are in place on the tank and properly sized for the specific unit being installed. Compare the model on the nameplate with the product information to ensure the Modulelevel transmitter is correct for the intended installation.

If the Modulelevel must be insulated, DO NOT insulate the transmitter head, e-tube or finned extensions.

Torque Specifications for Flange Bolting (with spiral wound gaskets) and Enclosing Tubes

Model	Flange Bolting	Enclosing tube
E4M - tank top (no chamber)	n/a	200 – 225 ft-lbs
External Chamber – 150#	110–120 ft-lbs	
External Chamber – 300#	180–200 ft-lbs	
External Chamber – 600#	180–200 ft-lbs	
External Chamber – 900#	370–400 ft-lbs	
External Chamber – 1500#	400–450 ft-lbs	
External Chamber – 2500#	675–725 ft-lbs	

2.4.1 Tank Top Installation (E4M – no chamber)

Figure 5 illustrates a typical tank top installation.

Before installing, ensure that:

- There is adequate headroom for the installation of the Modulelevel head and displacer and that it has unobstructed entry into the vessel.
- Using a level, the mounting flange is level within 3° in all directions.
- If the adjustable hanger assembly (P/N 32-3110-001) is used, it is cut to the required length and attached to the displacer stem.

NOTE: The adjustable hanger assembly is used when the top of the displacer and, therefore, the top of the measurement range must be positioned in the vessel more than 7.31" below the mounting flange for 0.55–2.20 SGs (up to 600#) and more than 9.31" below the mounting flange for all other SGs and all pressures greater than 600#. The standard hanger cable length is 2.5 meters (8 feet). Consult factory for longer cable.

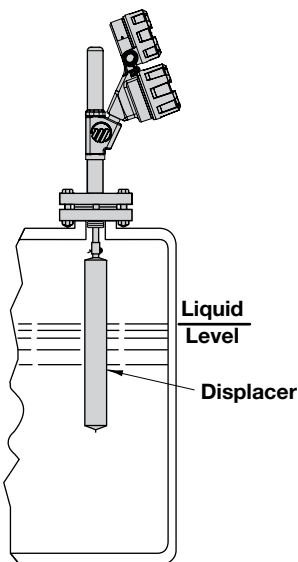

Figure 5
Tank Top Mounted Installation

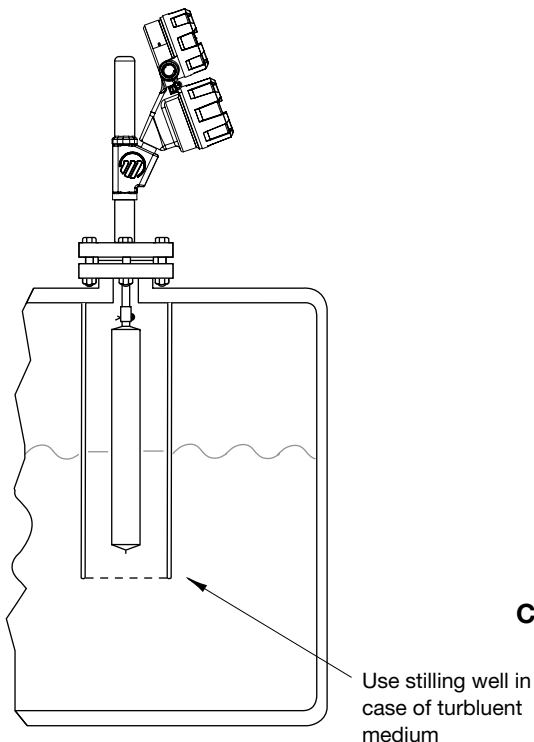

Figure 6
Tank Top Mounted
with Stilling Well

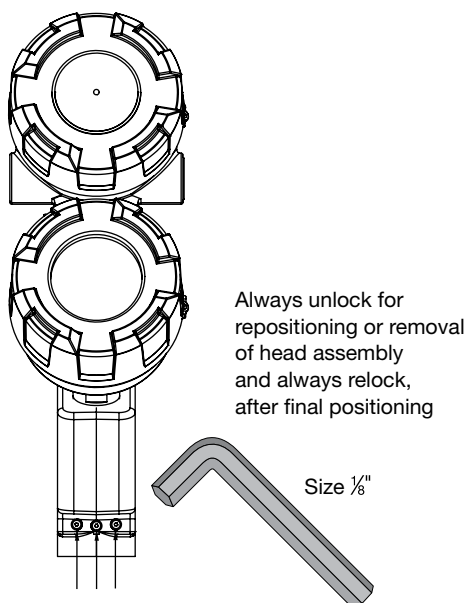

Figure 7
Transmitter Head
Lock Screws

- A stilling well is installed for applications where continuous agitation is present. The stilling well must be vertically level so as not to restrict displacer movement. See Figure 6 for a typical stilling well installation.
- The process temperature, pressure and specific gravity are within the unit's specifications for installation. See *Specifications, Section 3.6*.

To install:

1. Position the head flange gasket on the vessel flange and gently lower the displacer into the vessel. To prevent damage to the stem/spring assembly, avoid tipping the unit or, in any way, putting lateral forces on the stem.
2. Align the flanges and ensure that the gasket is seated properly.
3. Install the flange bolts and nuts and tighten alternating nuts in a star pattern. Flange bolting torque specifications are listed on page 10.

Caution: All Modulelevel units are shipped from the factory with the enclosing tube tightened and the transmitter head set screws locked to the enclosing tube. Failure to loosen the set screws prior to repositioning the supply and output connections may cause the enclosing tube to loosen, resulting in the possible leakage of the process liquid or vapor.

4. Loosen the transmitter head lock screws (socket type) and position conduit outlet in the desired direction. See Figure 7.
5. Retighten lock screws.

NOTE: Since the transmitter head is rotatable through 360°, it is important to make certain that the controller locking screws are tight before making electrical connections.

2.4.2 E4M – with chamber included

The chamber type Modulelevel is mounted on the side of the vessel with either a side/side or side/bottom connection, as furnished. Figure 8 on page 12 illustrates a typical chamber type installation.

Before installing, ensure that:

- There is adequate room for installation of the Modulelevel.
- Using a level, the vessel mounting connections are level within 3° in all directions.
- The process temperature, pressure and specific gravity are within the unit's specifications for installation. See *Specifications, Section 3.6*.
- If not already done, remove the shipping strap and wire assembly holding the displacer in place in the chamber. This assembly must be removed through the bottom chamber connection or drain before start-up.

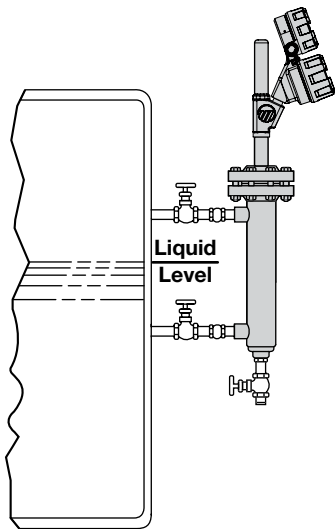

Figure 8
Chamber Type Installation
Side-Side Process Connections

To install:

1. Align the Modulelevel process connections with those on the vessel and attach accordingly, based upon the connection type. Appropriate gaskets and bolting will be required for flanged connections. Install the flange bolts and nuts and tighten alternating nuts in a star pattern. Flange bolting torque specifications are listed on page 10.

NOTE: It is recommended that shut-off valves be installed in each equalizing line to the chamber, along with a drain valve (refer to Figure 8). Equalizing lines should be sized at least as large as the connections provided at the chamber.

2. Make sure that the chamber is vertically level within 3° in each direction to ensure frictionless operation of the internal displacer.

Caution: All Modulelevel units are shipped from the factory with the enclosing tube tightened and the transmitter head set screws locked to the enclosing tube. Failure to loosen the set screws prior to repositioning the supply and output connections may cause the enclosing tube to loosen, resulting in the possible leakage of the process liquid or vapor.

3. Loosen the transmitter head lock screws (socket type) and position conduit outlet in the desired direction. See Figure 7.
4. Re-tighten lock screws.

NOTE: Since the transmitter head is rotatable through 360°, it is important to make certain that the controller locking screws are tight before making electrical connections.

2.4.3 E4T – Transmitter Replacement Only

Users have the option to retain existing Modulelevel displacer assemblies and convert only the electronics. This procedure is to convert Models EZ, ES, or E3 electronics to the E4T transmitter without interrupting the process.

2.4.3.1 Removal of the EZ, ES, ES II, or E3 Transmitter Head

1. Remove the power from the old Modulelevel.
2. Remove the transmitter and wiring housing covers.
3. Disconnect the field wiring in the wiring housing.
4. Remove the C-ring on the enclosing tube above the LVDT by using snap ring pliers.
5. Loosen the set screws in the hub of the housing base, and carefully lift the entire transmitter head assembly off the enclosing tube.
6. Set aside.

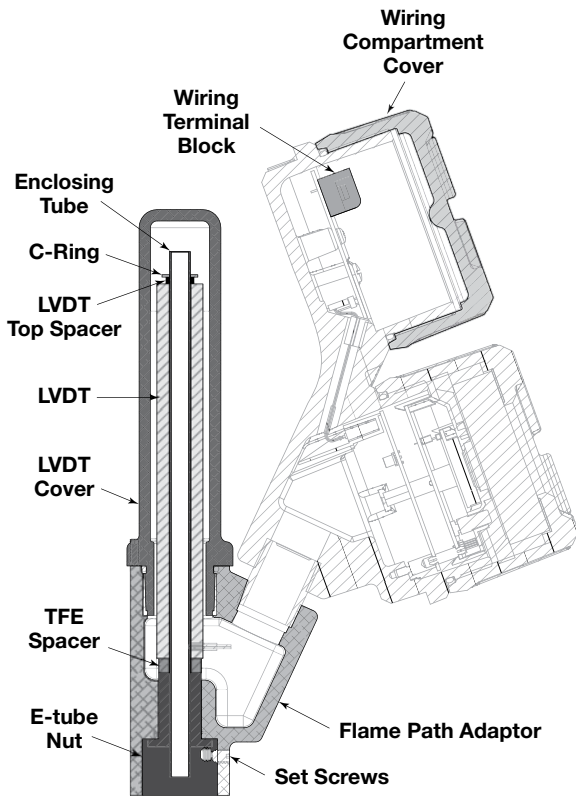

Figure 9
E4T Transmitter Replacement

2.4.3.2 Installation of the E4 Modulelevel Transmitter Head

1. Remove the wiring compartment and LVDT covers from the new E4 transmitter head assembly.
2. Remove the C-ring on the dummy enclosing tube above the LVDT by using snap ring pliers. Remove the LVDT top spacer.
3. Loosen the set screws at the base of the flame path adaptor, and carefully remove the dummy e-tube.
4. Lower the E4 transmitter head assembly onto the e-tube of the existing unit, being careful not to bend the e-tube.
5. Ensure that the flame path adaptor is seated all the way down on the e-tube nut.
6. Ensure that the TFE spacer is properly seated on the e-tube nut, inside the flame path adaptor.
7. Ensure that the LVDT assembly slides onto the e-tube and is seated all the way down on the TFE spacer.
8. Replace the LVDT top spacer and replace the C-ring on the e-tube above the LVDT by using snap ring pliers.
9. Rotate the transmitter head to the customer-preferred position and tighten the set screws at the base of the flame path adaptor.
10. Connect field wiring to the wiring board.
11. Replace wiring compartment and LVDT covers.
12. Apply power and check for output signal.
13. Calibrate the new transmitter. Refer to *Section 2.6.5.1, Dry and Wet User Calibration Procedures*.

2.5 Wiring

Caution: All versions of the E4 Modulelevel transmitter operate at voltages of 11–36 VDC. Higher voltage will damage the transmitter.

Wiring between the power supply and the E4 Modulelevel transmitter should be made using minimum of 18 AWG shielded twisted pair instrument cable. Wiring must be suitable for temperatures up to at least +85 °C. Within the transmitter enclosure, connections are made to the terminal strip and the ground connections. When installing a remote mount E4 transmitter, refer to Figures 12 & 13 for wiring connections.

The directions for wiring the E4 transmitter depend on the application:

- General Purpose or Non-incendive (CI I, Div. 2)
- Intrinsically Safe • Explosion Proof

2.5.1 General Purpose or Non-Incendive (CI I, Div. 2)

A general purpose installation does not have flammable media present. Areas rated non-incendive (CI I, Div. 2) have flammable media present only under abnormal conditions. No special electrical connections are required so standard installation methods may be followed.

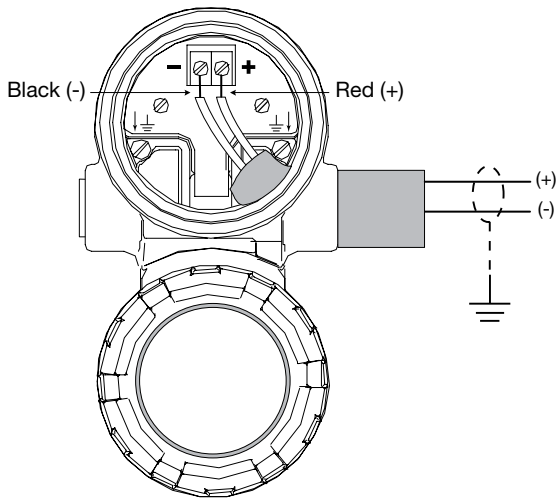

Figure 10
Wiring Diagram

To install General Purpose or Non-Incendive wiring:

1. Remove the cover to the wiring compartment of the transmitter. Install the conduit plug in the unused opening. Use PTFE tape/sealant to ensure a liquid-tight connection.
2. Install a conduit fitting and pull the supply wires.
3. Connect shield to an earth ground at power supply.
4. Connect an earth ground wire to the nearest green ground screw. Use a minimum 18 AWG rated up to 85 °C.
5. Connect the positive supply wire to the (+) terminal and the negative supply wire to the (-) terminal.
6. Replace the cover to the wiring compartment of the transmitter.

To install Remote Mount wiring:

1. Install conduit from the remote mounted head to the integral conduit connection of the E4 transmitter (refer to local plant or facility procedures).
2. Remove the cover of the remote transmitter, terminal board housing and of the integral terminal board housing.
3. Connect one end of the six conductor cable (P/N 037-3226-xxx or 037-3227-xxx) to the integral terminal block and the other end to the terminal block within the remote terminal board housing. Be sure to match the six discrete numbered wires with the numbers on each terminal block. See Figures 12 & 13.
4. Connect shield to an earth ground at the power supply.
5. Connect an earth ground wire to the nearest green ground screw per local electrical code (not shown in illustration).
6. Connect the positive supply wire to the (+) terminal and the negative supply wire to the (-) terminal.
7. Replace the covers to the wiring compartment of the transmitter and to both terminal board housings. Ensure that all covers are completely tightened down before applying power.

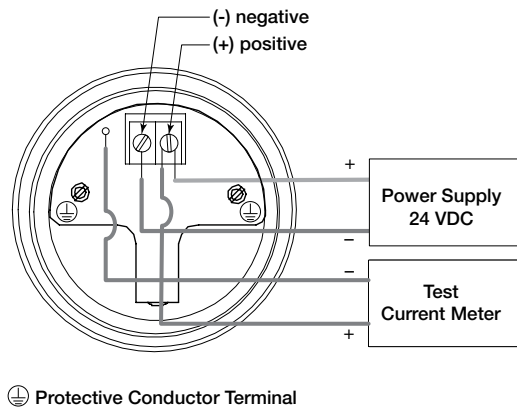

Figure 11
G.P./I.S./Explosion Proof Model

2.5.2 Intrinsically Safe

An intrinsically safe (IS) installation potentially has flammable media present. An approved IS barrier must be installed in the non-hazardous (safe) area. See agency drawing in *Section 3.4.2*.

To install Intrinsically Safe wiring:

1. Make sure the IS barrier is properly installed in the safe area (refer to local plant or facility procedures). Complete the wiring from the barrier to the E4 transmitter.
2. Remove the cover to the wiring compartment of the transmitter. Install the conduit plug in the unused opening. Use PTFE tape/sealant to ensure a liquid-tight connection.
3. Install a conduit fitting and pull the supply wires.
4. Connect shield to an earth ground at power supply.
5. Connect an earth ground wire to the nearest green ground screw.
6. Connect the positive supply wire to the (+) terminal and the negative supply wire to the (-) terminal.
7. Replace the cover to the wiring compartment of the transmitter.

2.5.3 Explosion Proof / Flameproof

Explosion Proof (XP) is a method of designing equipment for installation in hazardous areas. A hazardous location is an area in which flammable gases or vapors are, or may be, present in the air in quantities sufficient to produce explosive or ignitable mixtures. The wiring for the transmitter must be contained in Explosion Proof conduit extending into the safe area. See *Agency Approvals, Section 3.4*.

To install Explosion Proof wiring – Integral mount:

An Explosion Proof conduit fitting (EY seal) is required between the hazardous and safe areas.

1. Install Explosion Proof conduit from the safe area to the conduit connection of the E4 transmitter (refer to local plant or facility procedures).
2. Remove the cover to the wiring compartment of the transmitter.
3. Connect shield to an earth ground at the power supply.
4. Connect an Earth ground wire to the nearest green ground screw per local electrical code. Use a minimum 18 AWG rated up to 85 °C.
5. Connect the positive supply wire to the (+) terminal and the negative supply wire to the (-) terminal.
6. Replace the cover to the wiring compartment of the transmitter before applying power.

NOTE: When operated from a 24 VDC source, the maximum allowable loop resistance is 591 ohms for E4 Modulelevel units. When using HART, a loop resistance of 250 to 450 ohms must be placed in series with the E4 Modulelevel. See Figure 21 on page 41.

WARNING: DO NOT OPEN WHEN ENERGIZED

WARNING:
POTENTIAL ELECTROSTATIC CHARGING HAZARD – SEE INSTRUCTIONS

WARNING:
DO NOT OPEN WHEN AN EXPLOSIVE GAS ATMOSPHERE IS PRESENT. KEEP ASSEMBLY TIGHTLY CLOSED WHEN IN OPERATION. COVER JOINTS MUST BE CLEANED BEFORE REPLACING COVER.

AVERTISSEMENT:
NE PAS OUVRIR LORSQU'IL EST ÉNERGÉTIQUE

AVERTISSEMENT:
ÉLECTROSTATIQUE POTENTIEL RISQUE DE CHARGE – VOIR LES INSTRUCTIONS

AVERTISSEMENT:
NE PAS OUVRIR LORSQU'UN L'ATMOSPHÈRE DES GAZ EXPLOSIFS EST PRÉSENT. GARDEZ L'ASSEMBLAGE HERMÉMENT FERMÉ EN FONCTIONNEMENT. LES JOINTS DE COUVERCLE DOIVENT ÊTRE NETTOYÉS AVANT DE REMPLACER LE COUVERCLE.

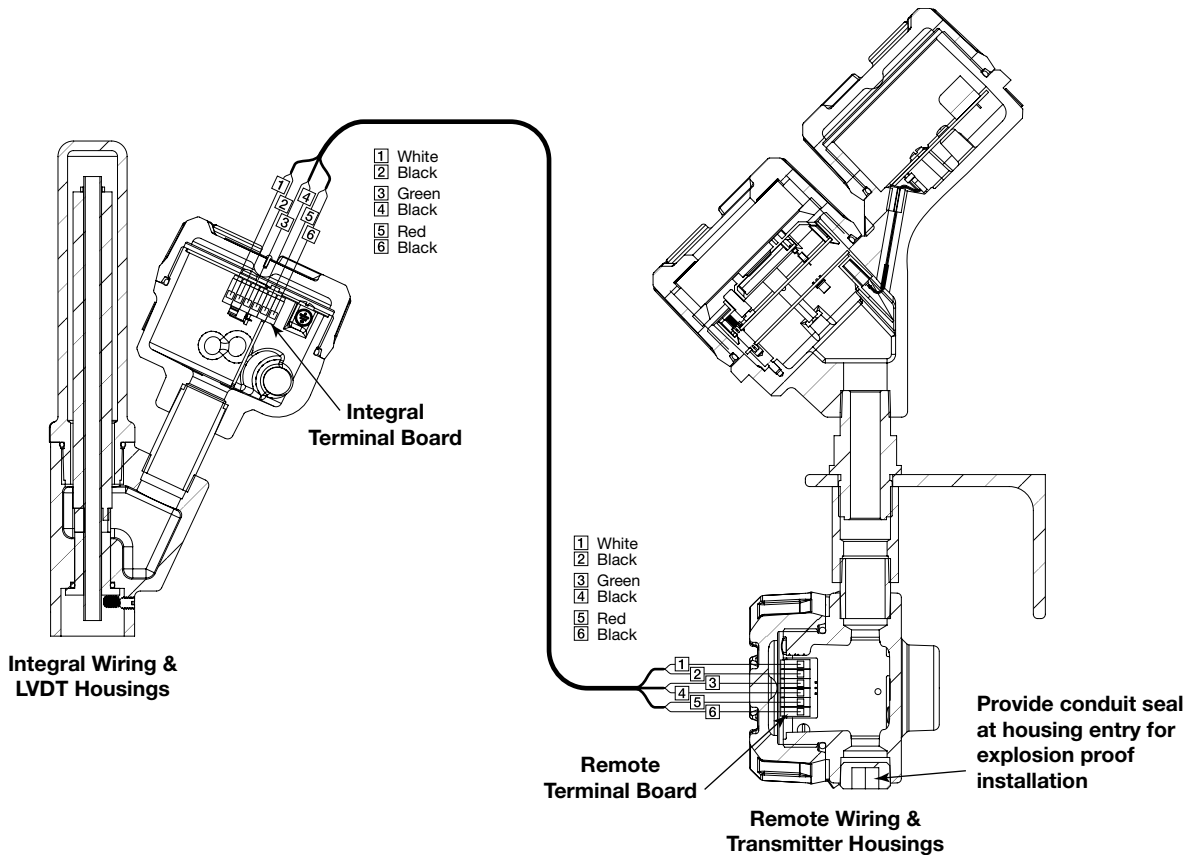

Figure 12
Remote Mount Wiring Connections

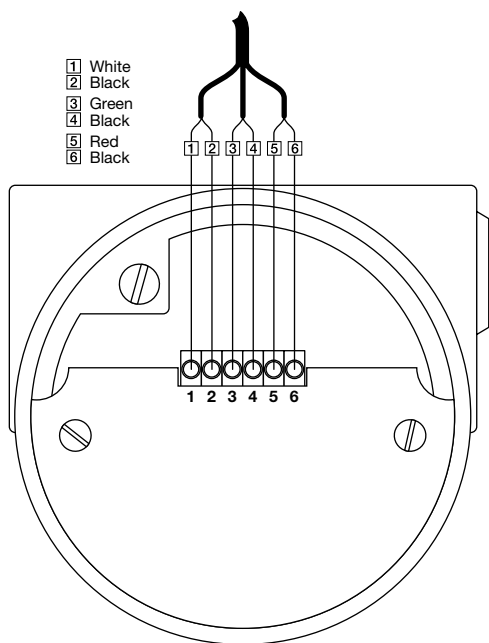

Figure 13
Integral & Remote Terminal Boards

To install Explosion Proof wiring – Remote mount:

1. Install Explosion Proof conduit from the remote mounted E4 transmitter head to the integrally mounted terminal housing at the LVDT. An Explosion Proof conduit fitting (EY seal) is required at the enclosure entry of the remote mounted transmitter head wiring housing (see figure 12). Follow steps 2 through 7 of Remote Mount wiring procedure on page 14.

2.6 Configuration

The E4 Modulelevel transmitter can be easily configured in the shop or at the installation using the local LCD/Keypad or PACTware/DTM. Bench configuration provides a convenient and efficient way to set up the transmitter before going to the tank site to complete the installation.

Before configuring any transmitter, collect all operating parameters information (refer to *Section 1.1.2*).

Apply power to the transmitter and follow the step-by-step procedures in this section for the menu-driven transmitter display.

Some key information is needed to configure the E4 transmitter. Complete the configuration information table. See *Section 1.1.2, Configuration Information*.

2.6.1 Menu Traversal and Data Entry

The four push buttons offer various forms of functionality for navigation and data entry.

The E4 Modulelevel user interface is hierarchical in nature, best described as a tree structure. Each level in the tree contains one or more items. Items are either menu labels or parameter names.

- Menu labels are presented in all capital letters
- Parameters are capital words

2.6.1.1 Navigating the Menu

- ⇧ UP moves to the previous item in the menu branch.
- ⇩ DOWN moves to the next item in the menu branch.
- ⇐ BACK moves back one level to the previous (higher) branch item.
- ⇒ ENTER enters into the lower level branch or switches to the entry mode. Holding the ENTER down on any highlighted menu name or parameter will show help text for that item.

2.6.1.2 Data Selection

This method is used for selecting configuration data from a specific list.

↑ UP and ↓ DOWN to navigate the menu and highlight the item of interest.

↵ ENTER allows modification of that selection.





↑ UP and ↓ DOWN to choose new data selection.

↵ ENTER to confirm selection.

Use ↵ BACK (Escape) key at any time to abort the procedure and escape to previous branch item.

2.6.1.3 Entering Numeric Data Using Digit Entry

This method is used to input numeric data, e.g., set values for LRV (4 mA) and URV (20 mA).





Push Button		Keystroke Action
	Up	Moves up to the next highest digit (0,1,2,3,....,9 or decimal point). If held down the digits scroll until the push button is released.
	Down	Moves down to the next lowest digit (0,1,2,3,....,9 or decimal point). If held down the digits scroll until the push button is released.
	Back	Moves the cursor to the left and deletes a digit. If the cursor is already at the leftmost position, then the screen is exited without changing the previously saved value.
	Enter	Moves the cursor to the right. If the cursor is located at a blank character position, the new value is saved.

All numeric values are left-justified, and new values are entered from left to right. A decimal point can be entered after the first digit is entered, such that .9 is entered as 0.9.

Some configuration parameters can have a negative value. In this case, the leftmost position is reserved for the sign (either “-” for a negative value, or “+” for a positive value).

2.6.1.4 Entering Numeric Data Using Increment/Decrement





Use this method to input the following data into parameters such as Damping and Failure Alarm.

Push Button		Keystroke Action
	Up	Increments the displayed value. If held down the digits scroll until the push button is released. Depending on which screen is being revised, the increment amount may increase by a factor of 10 after the value has been incremented 10 times.
	Down	Decrements the displayed value. If held down the digits scroll until the push button is released. Depending on which screen is being revised, the decrement amount may increase by a factor of 10 after the value has been decremented 10 times.
	Back	Returns to the previous menu without changing the original value, which is immediately redisplayed.
	Enter	Accepts the displayed value and returns to the previous menu.

2.6.1.5 Entering Character Data

This method is used for parameters requiring alphanumeric character entry, such as for entering tags.

General Menu Notes:

Push Button		Keystroke Action
	Up	Moves to the previous character (Z...Y...X...W). If held down, the characters scroll until the push button is released.
	Down	Moves to the next item character (A...B...C...D). If held down, the characters scroll until the push button is released.
	Back	Moves the cursor back to the left. If the cursor is already at the leftmost position, then the screen is exited without changing the original tag characters.
	Enter	Moves the cursor forward to the right. If the cursor is at the rightmost position, then the new tag is saved.

2.6.2 Password Protection

The E4 Modulelevel transmitter has three levels of password protection to restrict access to certain portions of the menu structure that affect the operation of the system. The user password can be changed to any numerical value up to 59999. When the transmitter is programmed for password protection, a password is required whenever configuration values are changed.

User Password

The User Password allows the customer to limit access to the basic configuration parameters.

The default User Password installed in the transmitter at the factory is 0. With a password of 0, the transmitter is no longer password protected and any value in the basic user menus can be adjusted without entering a confirming password.

NOTE: If a User Password is not known or has been misplaced, the menu item New Password in the DEVICE SETUP/ADVANCED CONFIG menu displays an encrypted value representing the present password. Contact Technical Support with this encrypted password to retrieve the original User Password.

Advanced Password

Certain portions of the menu structure that contain more advanced parameters are further protected by an Advanced Password.

This password will be provided, when necessary, by Factory technical support.

Factory Password

Calibration-related and other factory settings are further protected by a Factory Password.

2.6.3 Calibration Defaults

The E4 Modulelevel transmitter comes pre-calibrated from the factory. The default configuration is set up such that the level range is the length of the displacer with the 4 mA set point (LRV) at the bottom of the range and the 20 mA set point (URV) at the top. Field calibration is not required, but each unit must be configured for the process operating conditions. Level measurement applications require that the operating temperature and operating specific gravity be entered. For Interface and Specific Gravity measurement applications, only the operating temperature must be entered.

Additional calibration methods are made available to the user. This is accomplished through the User Calibration procedures found in *Section 2.6.5.1*.

2.6.4 E4 Modulelevel Menu: Step-By-Step Procedure

The following tables provide a complete explanation of the software menus displayed by the Modulelevel transmitter. The menu layout is similar between the local Keypad/LCD interface, the DD, and the DTM. Screens available for viewing may vary based on configuration settings.

Use these tables as a step-by-step guide to configure the transmitter based on desired measurement type from the following selections:

- **Level**
- **Interface Level**
- **Specific Gravity**

HOME SCREEN

The Home Screen consists of a 'slide show' sequence of Measured Values screens which are rotated at 2-second intervals. Each Home Measured Value screen can present up to four information items:

- **HART® Tag**
- **Measured Value**
Label, Numerical Value, Units
- **Status**
Will be displayed as text or optionally with NAMUR NE 107 symbol
- **Primary Value Bar Graph (shown in %)**

The Home Screen presentation can be customized by viewing or hiding some of these items. See DISPLAY CONFIG under the DEVICE SETUP menu in *Section 2.6.5, Configuration Menu*.

At left is an example of a Home Screen for a Model E4 configured for a Level application.



Up Down Back Enter

Figure 14

2.6.5 E4 Modulelevel Configuration Menu – Device Setup

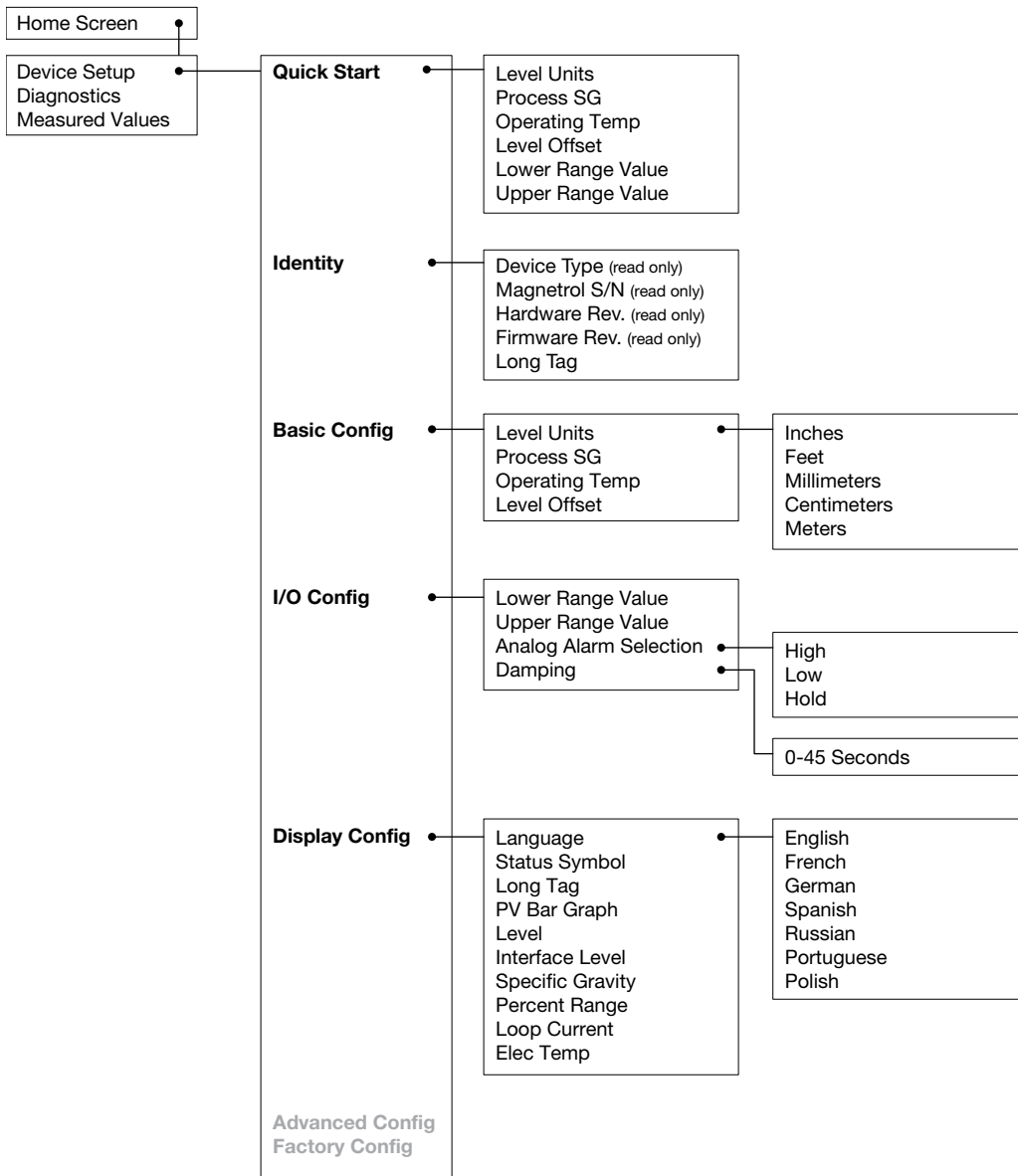

2.6.5 E4 Modulelevel Configuration Menu – Device Setup

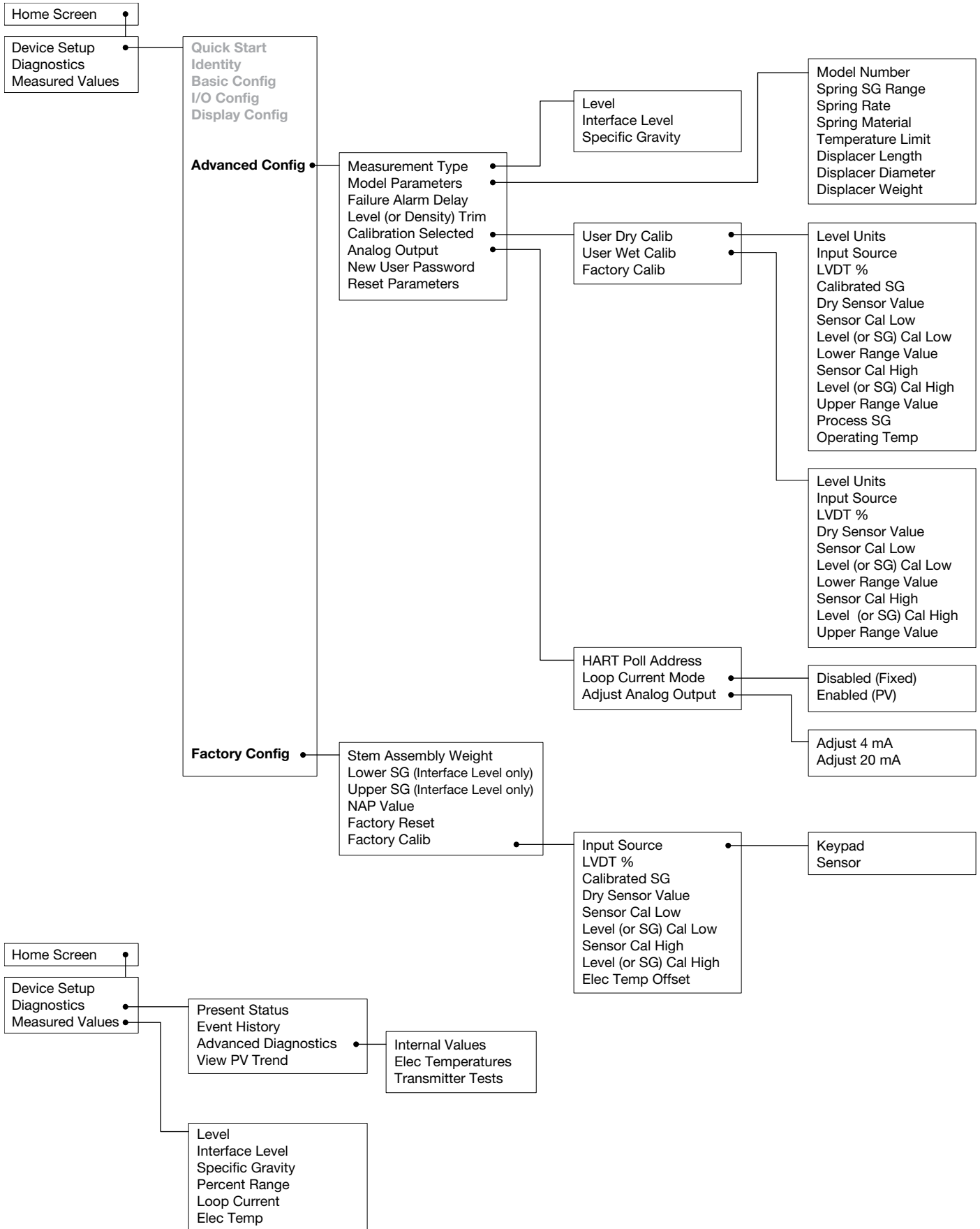

2.6.5.1 Dry and Wet User Calibration Procedures

The E4 Module level is calibrated at the factory and typically only requires basic configuration prior to operation. Should the E4 require replacement of parts in the field (i.e., electronic module, LVDT, range spring, stem assembly, or displacer), a user calibration must be performed. The following procedure should be followed when performing either a dry or wet user calibration in the field in the **Advanced Configuration** menu. It should be noted that this will override the factory calibration parameters.

User Dry Calibration – calibration option in the instrument shop using weights or displacer assemblies

1. If changes were made to the displacer from original application, go into Model Parameters and adjust displacer length/diameter/weight fields accordingly.
2. In the **Calibration Selected** field, select **User Dry Calib**
3. In User Dry Calib, select level units
4. Select input source for whether calibration will be performed with manual entry (keypad) or by capturing values and pressing Enter (sensor)
5. Place appropriate weight for dry and low level condition, which will be the same weight—users have the option of performing their own weight calculation using the process SG or by using the calibration SG from the table with the provided weight values
6. Capture sensor calibration low value (LVDT%)
7. Input specific gravity used for dry calibration
8. Input level value during low level condition (default is 0)
9. Input LRV (4 mA)
10. Adjust weights or displacer assembly for a desired high level condition
11. Capture sensor calibration high value (LVDT%)
12. Input level value during high level condition (default is displacer length)
13. Input URV (20 mA)
14. Input process/operating specific gravity
15. Input process/operating temperature
16. Resume operation

User Wet Calibration – performed under normal operating conditions in the process

1. If changes were made to the displacer from original application, go into **Model Parameters** and adjust displacer length/diameter/weight fields accordingly.
2. In the **Calibration Selected** field, select **User Wet Calib**
3. In User Wet Calib, select level units
4. Select input source for whether calibration will be performed with manual entry (keypad) or by capturing values and pressing Enter (sensor)

5. Input or capture dry sensor value in the process
6. Move level to low level condition (0%) and input or capture sensor calibration low value (LVDT%)
7. Input level value during low level condition (default is 0)
8. Input LRV (4 mA)
9. Move level to high level condition (100%) and input or capture sensor calibration high value (LVDT%)
10. Input level value during high level condition (default is displacer length)
11. Input URV (20 mA)
12. Resume operation

E4 Model Number Digit				CAL S.G.	LRV CAL (oz)	LRV CAL (g)	URV CAL (oz)	URV CAL (g)
12th	10th	12th	15th					
A, B, C, D, E, F, G, H	0	3, 4, 5, K, A, C, D, E, W, Z	A	0.5	43	1219	31.4	890
			B	0.5	43	1219	32.0	909
			C	0.5	43	1219	32.3	917
			D	0.5	43	1219	32.6	925
			E	0.5	44	1247	31.6	895
			F	0.5	44	1247	33.4	947
			G	0.5	44	1247	31.9	904
			H	0.5	44	1247	34.6	982
			I	0.5	44	1247	33.6	953
A, B, C, D, E, F, G, H	1	3, 4, 5, K, A, C, D, E, W, Z	A	1	43	1219	19.8	562
			B	1	43	1219	21.1	598
			C	1	43	1219	21.7	615
			D	1	43	1219	22.3	631
			E	1	44	1247	19.1	542
			F	1	44	1247	22.8	646
			G	1	44	1247	19.8	560
			H	1	44	1247	25.3	717
			I	1	44	1247	23.2	658
A, B, C, D, E, F, G, H	2	3, 4, 5, K, A, C, D, E, W, Z	A	2	58	1644	11.6	330
			B	2	58	1644	14.2	402
			C	2	58	1644	15.4	436
			D	2	58	1644	16.5	468
			E	2	58	1644	8.2	233
			F	2	58	1644	15.6	442
			G	2	58	1644	9.5	270
			H	2	58	1644	20.6	583
			I	2	58	1644	16.4	465
A, B, C, D, E, F, G, H	1	6, 7, 8, F, G, H, J, L, M, N	A	1	75.5	2140	54.6	1547
			B	1	75.5	2140	53.7	1522
			C	1	75.5	2140	54.2	1538
			D	1	79	2240	58.3	1653

2.7 Configuration Using HART

A HART (Highway Addressable Remote Transducer) remote unit, such as a HART communicator, can be used to provide a communication link to the E4 Module level transmitter. When connected to the control loop, the same system measurement readings shown on the transmitter are also shown on the communicator. The communicator can also be used to configure the transmitter.

The HART communicator may need to be updated to include the E4 Module level software (Device Descriptions). Refer to your HART Communicator Manual for update instructions.

One can also access configuration parameters using PACTware and the Model E4 DTM, or using the AMS with EDDL.

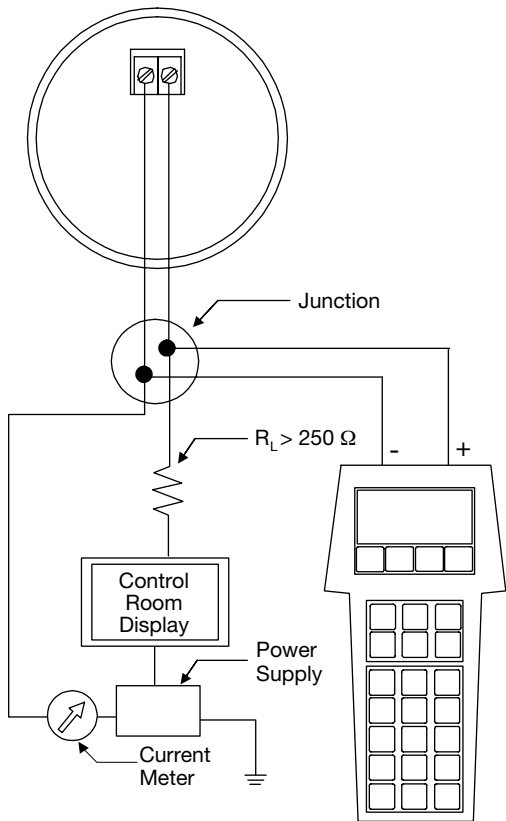

Figure 15

2.7.1 Connections

A HART communicator can be operated from a remote location by connecting it to a remote junction or by connecting it directly to the terminal block in the wiring compartment of the Model E4 transmitter.

HART uses the Bell 202 frequency shift keying technique of high-frequency digital signals. It operates on the 4–20 mA loop and requires 250 Ω load resistance. A typical connection between a communicator and the transmitter is shown at left.

2.7.2 HART Communicator Display

A typical communicator display is an 8-line by 21-character LCD. When connected, the top line of each menu displays the model and its tag number or address. For detailed operating information, refer to the instruction manual provided with the HART communicator.

2.7.3 HART Revision Table

E4 Module level

HART Version	HCF Release Date	Compatible with Software
Dev Rev 1, DD Rev 1	2023	Version 1.0a and later

2.7.4 HART Menu – Model E4

The E4 transmitter HART menu trees are shown in the following pages. Open the menu by pressing the alphanumeric key 4, then Device Setup, to display the second-level menu.

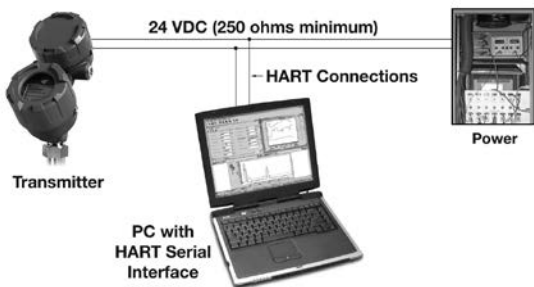
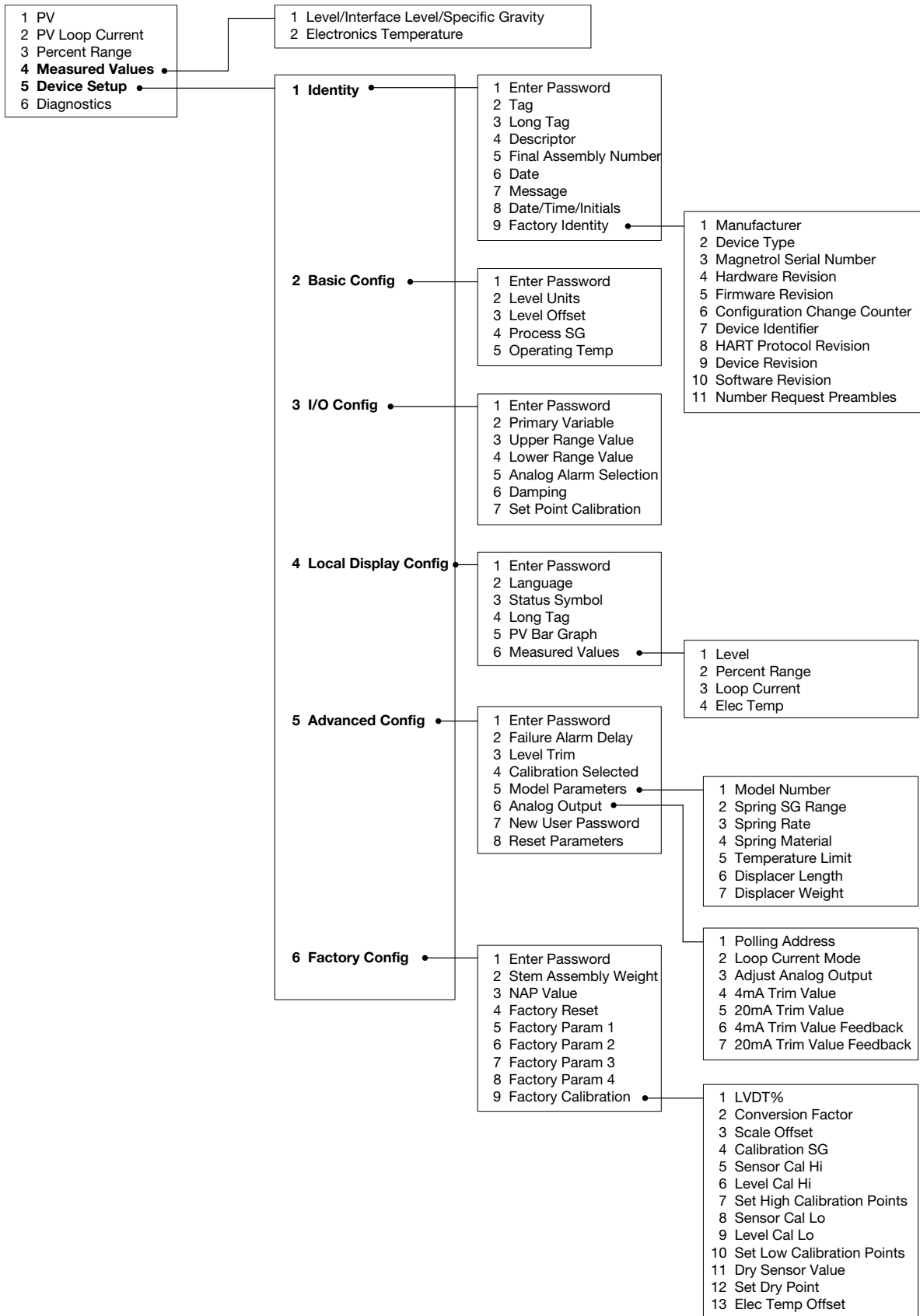
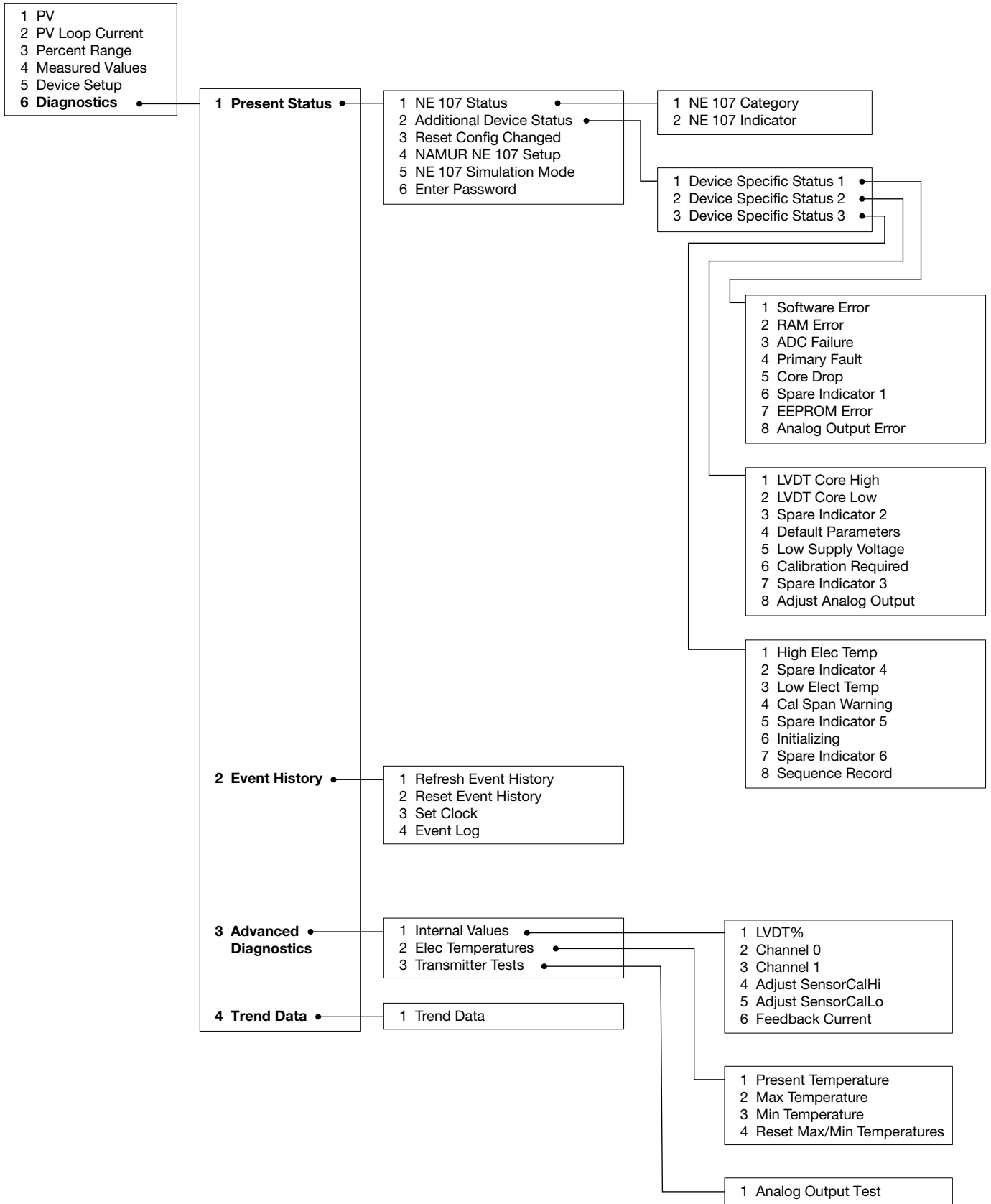

Figure 16

2.7.4 HART Menu (E4 Modulelevel®)



2.7.4 HART Menu (E4 Modulelevel®)



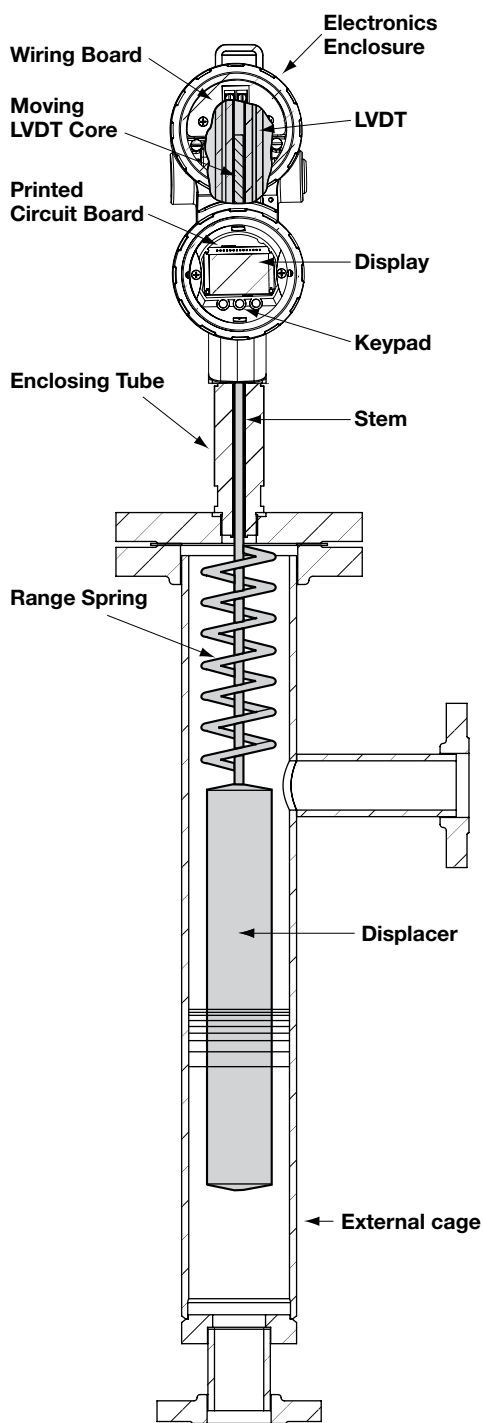

Figure 17
Electronic Modulelevel®
Components

3.0 Reference Information

This section presents an overview of the operation of the E4 Electronic Modulelevel Displacer Level Transmitter, information on troubleshooting common problems, listings of agency approvals, lists of replacement and recommended spare parts, and detailed physical, functional, and performance specifications.

3.1 Description

The E4 Modulelevel is a loop-powered, two-wire, 24 VDC level transmitter which utilizes simple buoyancy principles in combination with a precision range spring and a highly accurate LVDT (linear variable differential transformer) to detect and convert liquid level movement into a stable 4–20 mA output signal. The electronics are housed in an ergonomic, dual-compartment enclosure which is angled for ease of wiring and calibration.

3.2 Theory of Operation

The Electronic Modulelevel Displacer Level Transmitter relies on the principles of buoyancy to convert mechanical movement to an electronic output. See Figure 17.

3.2.1 Displacer/Range Spring

According to Archimedes' principle, the buoyancy force acting on an object immersed in liquid is equal to the weight of the liquid displaced. As the level changes, the volume of displacer submerged in the liquid changes, thus varying the buoyancy force acting on the displacer. This change is detected by the precision range spring from which the displacer hangs, causing it to elongate or compress. The change in spring length causes movement of a special LVDT core which is mounted on a rigid stem attached to the spring.

3.2.2 LVDT

E4 Modulelevel utilizes highly precise LVDT technology to convert the movement of the LVDT core within the LVDT to a stable 4–20 mA output signal. The position of the core with respect to a primary and two secondary windings within the LVDT, induces a voltage in each winding. The comparison of the induced voltages within the microprocessor of the E4 results in very accurate level output.

3.2.3 Interface

E4 Modulelevel is capable of tracking the interface level of two immiscible liquids with different densities. Each unit is custom-made with a displacer specially designed for the user's application. This allows it to detect the position of a clean interface or an emulsion layer and convert it into a stable 4–20 mA signal. Contact the factory for assistance in specifying an E4 for interface service. Note that for proper interface detection, the entire displacer must always be immersed in liquid.

3.2.4 Specific Gravity

Yet another capability of E4 Modulelevel is to track the changing density of a liquid over a known density range and convert that into a stable 4–20 mA output signal. As the density of the liquid changes, so does the mass of the liquid displaced by the specially designed displacer. The resulting change in buoyancy force on the displacer causes the movement of the LVDT core necessary to convert the density change to the 4–20 mA signal.

3.3 Troubleshooting and Diagnostics

The E4 Modulelevel transmitter is designed and engineered for trouble-free operation over a wide range of operating conditions. The transmitter continuously runs a series of internal self-tests and displays helpful messages on the large graphic liquid crystal display (LCD) when attention is required.

The combination of these internal tests and diagnostics messages offer a valuable proactive method of troubleshooting. The device not only tells the user what is wrong, but also, and more importantly, offers suggestions on how to solve the problem.

All of this information can be obtained directly from the transmitter on the LCD, or remotely by using a HART communicator or PACTware and the DTM.

PACTware™ PC Program

The E4 Modulelevel offers the ability to perform more advanced diagnostics using a PACTware DTM. This is a powerful troubleshooting tool that can aid in the resolution of any diagnostic indicators that may appear.

3.3.1 Diagnostics (NAMUR NE 107)

The E4 Modulelevel transmitter includes an exhaustive list of Diagnostic Indicators which follow the NAMUR NE 107 guidelines.

NAMUR is an international user association of automation technology in process industries, whose goal is to promote the interest of the process industry by pooling experiences among its member companies. In doing so, this group promotes international standards for devices, systems, and technologies.

The objective of NAMUR NE 107 was essentially to make maintenance more efficient by standardizing diagnostics information from field devices. This was initially integrated via Foundation fieldbus, but the concept applies regardless of the communication protocol.

According to the NAMUR NE107 recommendation, "Self Monitoring and Diagnosis of Field Devices," fieldbus diagnostic results should be reliable and viewed in the context of a given application. The document recommends categorizing internal diagnostics into four standard status signals:

- Failure
- Function Check
- Out of Specification
- Maintenance required

These categories are shown by both symbols and colors, depending on the display capability.

In essence, this approach ensures that the right diagnostic information is available to the right person-at the right time. In addition, it allows diagnostics to be applied, as most appropriate, for a particular plant application (such as process control engineering or asset management maintenance). Customer specific mapping of diagnostics to these categories allows for flexible configuration depending on the user's requirements.

From an external Model E4 transmitter perspective, diagnostic information includes measurement of process conditions, in addition to detection of internal device or system anomalies.

As mentioned above, the indicators can be assignable (via the DTM or host system) by the user to any (or none) of the NAMUR recommended Status Signal categories: Failure, Function Check, Out of Specification, and Maintenance Required.

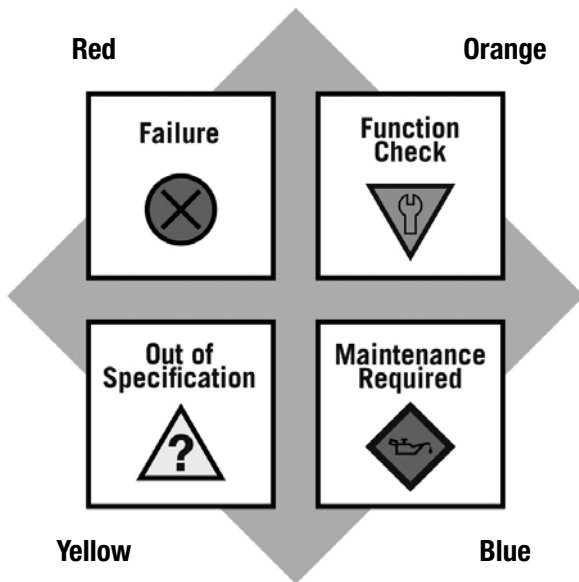

Indicators that are mapped to the Failure category will normally result in a current loop alarm output. The alarm state for HART transmitters is configurable as high (22 mA), Low (3.6 mA), or Hold (last value).

Users will not have the ability to unassign certain indicators from the Failure signal category as the Model E4 user interfaces will prohibit or reject such re-assignment entries). This is to ensure that current loop alarms are asserted in situations where the device is not able to provide measurements due to critical failures. (For example, if the alarm selection has not been set to Hold, or a fixed current mode is in effect.)

A default mapping of all diagnostic indicators will be applied initially, and can be re-applied through use of a reset function.

Refer to the table on the following pages for a complete listing of the Model E4 diagnostic indicators, along with their explanations, default categories, and recommended remedies.

- NOTES: 1. The remedies shown in this table can also be seen on the transmitter LCD by viewing the present status screen when the device is in a diagnostic condition.
2. Those indicators showing failure as the default result in an alarm condition.

3.3.2 Diagnostic Indication Simulation

The DD and DTM allow for the ability to manipulate diagnostic indicators. Intended as a means to verify the configuration of the diagnostic parameters and connected equipment, a user can manually change any indicator to and from the active state.

3.3.3 Diagnostic Indicator Table

Below is a listing of the E4 Module level diagnostic indicators, showing their priority, descriptions and recommended remedies. (Priority 1 is highest priority.)

Priority	Indicator Name	Default Category	Description	Remedy
1	Software Error	Failure	Incorrect instruction sequence or other software malfunction	Contact Technical Support
2	RAM Error	Failure	Run-time volatile memory test failed	Contact Technical Support
3	ADC Error	Failure	Run-time analog to digital test failed.	Contact Technical Support
4	Primary Fault	Failure	LVDT Primary circuit open condition	Check LVDT winding resistance; replace LVDT if values are out of range
5	Core Drop	Failure	Core too far out	Check for lost or damaged LVDT core; check LVDT winding resistance
6	Spare Indicator1	None	None	
7	EEPROM Error	OK	Non-volatile parameter storage failing	Contact Technical Support
8	Analog Output Error	Failure	Measured loop current differs from commanded value	Perform loop trim operation
9	LVDT Core High	Failure	A/D readings from LVDT secondary windings not in expected range – Core position too high	Check for missing displacer; check LVDT winding resistance
10	LVDT Core Low	Failure Out of Spec [Interface] ①	A/D readings from LVDT secondary windings not in expected range – Core position too low	Check for broken spring or leaking displacer; check LVDT winding resistance
11	Spare Indicator2	None	None	
12	Default Parameters	Failure	Some parameters reset to default values	Perform complete device setup
13	Low Supply Voltage	Out of Spec	Power supply voltage inadequate to prevent brownout or reset	Verify adequate power supply; verify loop resistance is < 591 ohms
14	Calibration Required	Out of Spec	Calibration Required	Perform user calibration or contact Technical Support
15	Spare Indicator3	None	None	
16	Adjust Analog Out	Out of Spec	Loop trim parameters are at default values	Perform loop trim operation
17	High Elec Temp	Out of Spec	Present electronics temperature above maximum	Controlled external cooling may be required or change to remote mount transmitter
18	Spare Indicator4	None	None	
19	Low Elec Temp	Out of Spec	None	Controlled external heating may be required or change to remote mount transmitter
20	Cal Span Warning	Out of Spec	Span of sensor calibration points is below minimum required	Recalibrate or reconfigure with longer span
21	Spare Indicator5	None	None	
22	Initializing	Function Check	System warming up, distance measurement not yet valid	Wait for up to 10 seconds
23	Spare Indicator6	None	None	
24	Sequence Record	No effect	Instruction execution followed a valid but unexpected sequence	

① If Measurement Type is Interface Level, LVDT Core Low category will be Out of Spec, otherwise it will be Failure.

3.3.4 Troubleshooting System Problems

Symptom	Problem	Solution
No loop current.	Power supply not turned on.	Turn on power.
	Insufficient source voltage.	E4 requires a minimum of 11 VDC at the wiring board. Verify supply voltage.
	Improperly wired or damaged wiring.	Check wiring and connections.
	Defective electronics.	Replace PC board assembly or wiring board as required.
LEVEL, % OUTPUT and LOOP values are all inaccurate.	Basic configuration data is questionable.	Verify Level Offset values. If using factory calibration, verify that Process SG and Operating Temperature values are accurate. Verify/confirm that Model Parameters are accurate. Confirm set points are as expected.
Transmitter does not track level.	Model incompatible with process liquid	Verify model in use is appropriate for process liquid SG.
	Possible damage to unit.	Check displacer, spring, stem and enclosing tube for damage. Replace all damaged parts.
	Possible material buildup	Check displacer, spring, stem, enclosing tube and displacer for buildup of process material. Clean any fouled parts.
	Displacer, spring or stem dragging on inside of chamber, e-tube.	Verify proper and level installation (within 3 degrees of plumb in all directions).
Level reading on display is correct, but loop value is stuck at 4 mA.	Invalid poll address.	Set poll address to 0 if not using multi-drop. Ensure Loop Current Mode is set to Enabled.
LEVEL, % OUTPUT and LOOP values fluctuate.	Liquid turbulence.	Increase damping until output stabilizes or install stilling well.
	Power supply unstable.	Repair or replace power supply.
	Electrical interference (RFI).	Consult factory for assistance.
HART device only: Handheld will only read Universal Commands	Most current Device Descriptors are not installed in handheld.	Download latest DD per the HART section of the manual.
Cannot set high level to 20 mA	Incorrect power supply.	Check power supply.
	Excessive loop resistance	Increase power supply voltage or decrease loop resistance
Loop current less than 4 mA	Liquid level less than 0%.	No action required.
	Supply voltage out of limits at transmitter.	Adjust power supply or reduce loop resistance.
4 mA output does not match display	4 mA may need to be trimmed.	Use Trim 4 mA to adjust output to match display.
Loop current exceeds 20 mA	Liquid level greater than 100%.	No action required.
	Supply voltage out of limits at transmitter.	Adjust power supply or reduce loop resistance.
	Wired incorrectly.	Check power supply (+) and (-) for reverse wiring.
	Active failure driving mA high	Consult factory for assistance.
20 mA output does not match display	20 mA may need to be trimmed.	Use Trim 20 mA to adjust output to match display.
Output jumps quickly over wide range	Bent stem impeding smooth core movement	Review Event History. Inspect stem and replace if damaged.
Non-linear output.	Excessive loop resistance.	Increase power supply voltage or decrease loop resistance.
	Displacer hanging up.	Verify proper and level installation (within 3 degrees of plumb in all directions.)
	Bent stem.	Check stem. Replace if damaged.
	Possible material buildup	Check displacer, spring, stem, enclosing tube and displacer for buildup of process material. Clean any fouled parts.

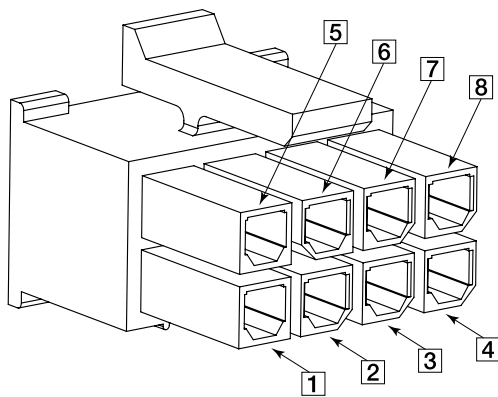

Figure 18
LVDT Eight-Pin Connector

3.3.5 Checking the LVDT Winding Resistance

WARNING! To prevent ignition of explosive atmospheres, disconnect power before servicing.

1. Remove power from the unit.
2. Remove the electronics housing cover and the electronics bezel assembly.
3. Disconnect the eight-pin connector J1 from the back of the PC board assembly.
4. Using a multimeter, check the primary winding by verifying that pins 6 and 7 of the eight-pin connector have approximately 75 to 105 ohms resistance.
5. Check the secondary winding by verifying that pins 1 and 5 or pins 4 and 8 of the eight-pin connector have approximately 70 to 100 ohms resistance.
6. If the winding resistance is out of range, replace LVDT.

3.4 Agency Approvals



These devices are in compliance with the RED-directive 2014/53/EU, the EMC directive 2014/30/EU, the PED-directive 2014/68/EU, the ATEX directive 2014/34/EU and RoHS directive 2011/65/EU.

Explosion Proof

US/Canada – FM23US0028X/FM23CA0021X:

Class I, Div 1, Group B, C and D, T5
SINGLE SEAL
Ta = -40°C to +80°C
Type 4X, IP66, IP67

Flame Proof

ATEX – FM23ATEX0017X/FM23UKEX0024X:

II 2 G Ex db IIC T6...T1 Ga/Gb
Ta = -40°C to +70°C
IP66, IP67

IEC – IECEx FMG 23.0009X:

Ex db IIC T6...T1 Ga/Gb
Ta = -40°C to +70°C
IP66, IP67

Intrinsically Safe

US/Canada – FM23US0028X/FM23CA0021X

Class I, II, III, Div 1, Group A, B, C, D, E, F, G, T4
Ta = -40°C to + 80°C
Type 4X, IP66, IP67

ATEX – FM23ATEX0017X/FM23UKEX0024X:

II 1 G Ex ia IIC T4 Ga
Ta = -40°C to +70°C
IP66, IP67

ATEX – FM23ATEX0025X/FM23UKEX0028X:

II 3 G Ex ic IIC T4 Gc
Ta = -40°C to +70°C
IP66, IP67

IEC – IECEx FMG 23.0009X:

Ex ia IIC T4 Ga
Ex ic IIC T4 Gc
Ta = -40°C to +70°C
IP66, IP67

Non- Incendive

US/Canada – FM23US0028X/FM23CA0021X:

US: Class I, II, III, Division 2, Group A, B, C, D, E, F, G, T4
Canada: Class I, Division 2, Group A, B, C, D
SINGLE SEAL
Ta = -40°C to +70°C
Type 4X, IP66, IP67

Dust Ignition Proof

US/Canada – FM23US0028X/FM23CA0021X:

Class II, III, Division 1, Group E, F and G, T5
SINGLE SEAL
Ta = -40°C to +80°C
Type 4X, IP66, IP67

On remote electronics housing only, seal is required at the enclosure.

See appropriate Installation & Operating Manual for entity parameters for IS installation.

Entity Parameters:

$V_{\max} = 28.6 \text{ V}$ $P_{\max} = 1 \text{ W}$ $L_i = 2.7 \text{ } \mu\text{H}$
 $I_{\max} = 140 \text{ mA}$ $C_i = 4.4 \text{ nF}$

3.4.1 Special Conditions of Use

1. Some of the enclosures contains aluminum and are considered to present a potential risk of ignition by impact or friction. Care must be taken during installation and use to prevent impact or friction.
2. The installer must ensure the process temperature must not increase the ambient temperature above 80°C for Division rating and 70°C for Zone rating.
3. Refer to the manufacturer's instructions to reduce the potential of an electrostatic charging hazard on the equipment enclosure.
4. The flamepaths of the equipment are not intended to be repaired. Consult the manufacturer if repair of the flamepath joints is necessary.
5. For installation with ambient temperature of 70 °C, refer to the manufacturer's instruction for guidance on proper selection of conductors.
6. Partition wall material shall not be subject to environmental conditions which might adversely affect the partition wall integrity.
7. Model E4T Modulelevel Transmitter can only be retrofitted onto EZ, ES, E3 or E4 Models marked with US, Canadian, ATEX and IECEx Hazardous Locations certification.
8. Temperature class for the process temperatures is defined by the following table:

Temperature Class Value (Gas)	T-Max (Process)
T6	+80 °C
T5	+95 °C
T4	+130 °C

Temperature Class Value (Gas)	T-Max (Process)
T3	+195 °C
T2	+295 °C
T1	+445 °C

3.4.2 Agency Drawing

HAZARDOUS LOCATION

MODULE LEVEL TRANSMITTER

INTRINSICALLY SAFE FOR:
 CLASS I, DIV I GROUPS A, B, C, D
 CLASS II, DIV I GROUPS E, F, G
 CLASS III
 II 1 G Ex ia IIC T4 Ga
 Ex ia IIC T4 Ga
 II 3 G Ex ic IIC Gc
 Ex ic IIC Gc

ENTITY
 $V_{max}/U_i = 28.6V$
 $I_{max}/I_i = 140mA$
 $P_{max}/P_i = 1W$
 $C_i = 4.4nF$
 $L_i = 2.7\mu H$

MODEL E4X-5XXX-XXX

TRANSMITTER
INSTRUMENT

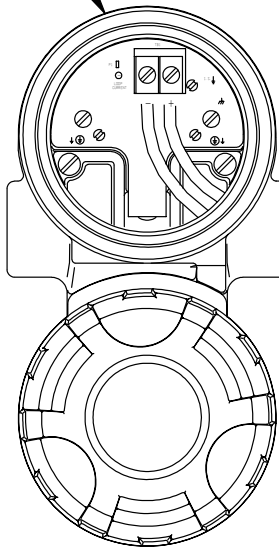

NON-HAZARDOUS LOCATION

LIMITING VALUES

ENTITY
 $V_{oc} \leq 28.6V$ $C_a \geq 4.4nF$
 $I_{sc} \leq 140mA$ $L_a \geq 2.7\mu H$
 $P_o \leq 1W$

THE VOLTAGE (V_{max}) AND CURRENT (I_{max}), WHICH THE TRANSMITTER CAN RECEIVE MUST BE EQUAL TO OR GREATER THAN THE MAXIMUM OPEN CIRCUIT VOLTAGE (V_{oc} OR V_+) AND THE MAXIMUM SHORT CIRCUIT CURRENT (I_{sc} OR I_E), WHICH CAN BE DELIVERED BY THE SOURCE DEVICE. IN ADDITION, THE MAXIMUM CAPACITANCE (C_i) AND INDUCTANCE (L_i) OF THE LOAD AND THE CAPACITANCE AND INDUCTANCE OF THE INTERCONNECTING WIRING, MUST BE EQUAL TO LESS THAN THE CAPACITANCE (C_a) OR THE INDUCTANCE (L_a), WHICH CAN BE DRIVEN BY THE SOURCE DEVICE.

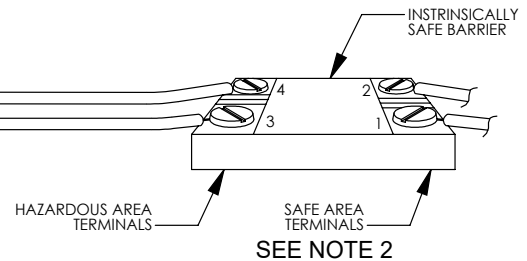

NOTES:

1. MANUFACTURER'S INSTALLATION INSTRUCTIONS SUPPLIED WITH THE PROTECTIVE BARRIER AND THE NEC AND ANSI/ISA RP 12.6 [FOR FMRC] MUST BE FOLLOWED WHEN INSTALLING THIS EQUIPMENT. BARRIER MUST BE FM APPROVED FOR U.S. INSTALLATION.
2. CONTROL EQUIPMENT CONNECTED TO PROTECTIVE BARRIERS MUST NOT USE OR GENERATE MORE THAN 250 VDC OR VRMS. RESISTANCE BETWEEN INTRINSICALLY SAFE GROUND AND EARTH GROUND MUST BE LESS THAN 1.0 OHM.
3. NRTL LISTED DUST-TIGHT SEALS MUST BE USED WHEN TRANSMITTER IS INSTALLED IN CLASS II & III ENVIRONMENTS.
4. NO REVISIONS TO THIS DRAWING WITHOUT FMRC APPROVAL.
5. WARNING - EXPLOSION HAZARD - SUBSTITUTION OF COMPONENTS MAY IMPAIR SUITABILITY FOR HAZARDOUS LOCATIONS.
6. FOR SUPPLY CONNECTIONS, USE WIRE SUITABLE FOR THE OPERATING TEMPERATURE. FOR 80° C AMBIENT, USE WIRE WITH A MINIMUM TEMPERATURE RATING OF 85° C.
7. THE TRANSMITTER CAN ALSO BE INSTALLED IN:
 CLASS I, DIVISION 2, GROUPS A, B, C & D
 CLASS II, DIVISION 2, GROUPS E, F & G
 CLASS III, DIVISION 2, HAZARDOUS LOCATIONS AND DOES NOT REQUIRE CONNECTION TO A PROTECTIVE BARRIER WHEN INSTALLED PER THE NEC/CEC AND WHEN CONNECTED TO A POWER SOURCE NOT EXCEEDING 30 VDC. FIELD WIRING MUST BE INSTALLED IN CONDUIT PER THE NEC/CEC.
8. WARNING: TO PREVENT IGNITION OF FLAMMABLE OR COMBUSTIBLE ATMOSPHERES DISCONNECT POWER BEFORE SERVICING.
9. USE THIS DEVICE ONLY AS SPECIFIED IN THE INSTALLATION AND OPERATING MANUAL.
10. FM CERTIFIED BARRIERS WITH LINEAR OUTPUT CHARACTERISTICS **MUST BE USED**.

099-5085-A

3.5 Parts

3.5.1 Replacement Transmitter Head Parts

1a	Electronic Module HART	Z31-2883-001
1b	Display Module	Z31-2850-001
2	Wiring Board	
	HART	Z30-9180-001
3	Transmitter Housing O-rings (2 required)	012-2201-237
4	Transmitter Housing Cover Kits – Contains parts 4a and 4b (Consult Factory)	
4c	Terminal Junction Box Covers (2 required) (Consult Factory)	
5	LVDT Kit – Contains parts 5, 8, 9, and 10	
	Low Temperature (9th digit A, B, D, G)	089-7827-011*
	Mid Temperature (9th digit C, E)	089-7827-012*
	High Temperature (9th digit F, H, J)	089-7827-013*
6	LVDT Housing Cover Kits (Consult Factory)	
7	LVDT Cover O-ring	012-2222-123
11	Remote Terminal Boards (2 required)	030-9824-001
12	Remote Transmitter Jumper Cable	037-7917-002

* Field replacement of this part requires a user calibration of the repaired unit.

3.5.2 Mechanical Replacement Parts

Pressure Rating	Process Temperature (9th Digit)	Spring SG Range	E-tube Kits ⁽¹³⁾	Stem Kit* ⁽¹⁴⁾	Spring Kits* ⁽¹⁵⁾
			CSA, FM, ATEX, IEC, 316 SS		Inconel®
150#, 300# & 600# ANSI	B, C	0.23 – 0.54	089-5958-006	089-5565-004	089-5340-002
		0.55 – 1.09			089-5340-005
		1.10 – 2.20			089-5340-008
	G	0.23 – 0.54	089-5958-008	089-5565-008	089-5340-003
		0.55 – 1.09			089-5340-006
		1.10 – 2.20			089-5340-009
	A	0.23 – 0.54	089-5958-001	089-5565-002	089-5340-002
		0.55 – 1.09			089-5340-005
		1.10 – 2.20			089-5340-008
	D, E	0.23 – 0.54	089-5958-003	089-5565-006	089-5340-002
		0.55 – 1.09			089-5340-005
		1.10 – 2.20			089-5340-008
H	0.23 – 0.54	089-5958-007	089-5565-006	089-5340-003	
	0.55 – 1.09			089-5340-006	
	1.10 – 2.20			089-5340-009	
900# ANSI	B, C	0.55 – 1.09	089-5958-014	089-5565-004	089-5340-010
	G		089-5958-016	089-5565-008	
	A		089-5958-013	089-5565-002	
	D, E		089-5958-015	089-5565-006	
1500# & 2500# ANSI	B, C	0.55 – 1.09	n/a	089-5565-004	
	G			089-5565-008	
	A			089-5565-002	
	D, E			089-5565-006	

* Field replacement of this part requires a user calibration of the repaired unit.

Cage Pressure Rating	Head Flange Size	⑩ Head Flange Kit	
		Carbon Steel	316 SS
150# ANSI	3"	89-4242-001	89-4242-017
	4"	89-4242-005	89-4242-021
	6"	89-4242-011	89-4242-027
300# ANSI	3"	89-4242-002	89-4242-018
	4"	89-4242-006	89-4242-022
	6"	89-4242-012	89-4242-028
600# ANSI	3"	89-4242-003	89-4242-019
	4"	89-4242-007	89-4242-023
	6"	89-4242-013	89-4242-029
900# ANSI	3"	89-4242-004	89-4242-020
	4"	89-4242-008	89-4242-024
	6"	89-4242-014	89-4242-030
1500# ANSI	4"	89-4242-009	89-4242-025
	6"	89-4242-015	89-4242-031
2500# ANSI	4"	89-4242-010	89-4242-026
	6"	89-4242-016	89-4242-032

⑪ Displacer Kits *			
	150, 300, 600#		High Pressure 900, 1500, 2500#
	S.G. Range		S.G. Range
	0.23 – 0.54 & 0.55 – 1.09	1.10 – 2.2	0.55 – 1.09
14"	89-6125-001	89-6126-001	89-6125-010
32"	89-6125-002	89-6126-002	89-6125-011
48"	89-6125-003	89-6126-003	89-6125-012
60"	89-6125-004	89-6126-004	89-6125-013
72"	89-6125-005	89-6126-005	n/a
84"	89-6125-006	89-6126-006	n/a
96"	89-6125-007	89-6126-007	n/a
108"	89-6125-008	89-6126-008	n/a
120"	89-6125-009	89-6126-009	n/a

⑫ Displacer Kits *	
14"	89-6126-001

Kit Definitions

Head flange kit includes: head flange, studs, nuts and gasket (top mounting units) or head flange only (chambered unit)

E-tube kits include: E-tube, E-tube extension(s) and gasket

Stem kits include: stem assembly, stem extension, LVDT core

Spring kits include: spring assembly, screws and lockwashers

Displacer kits include: displacer and cotter pins

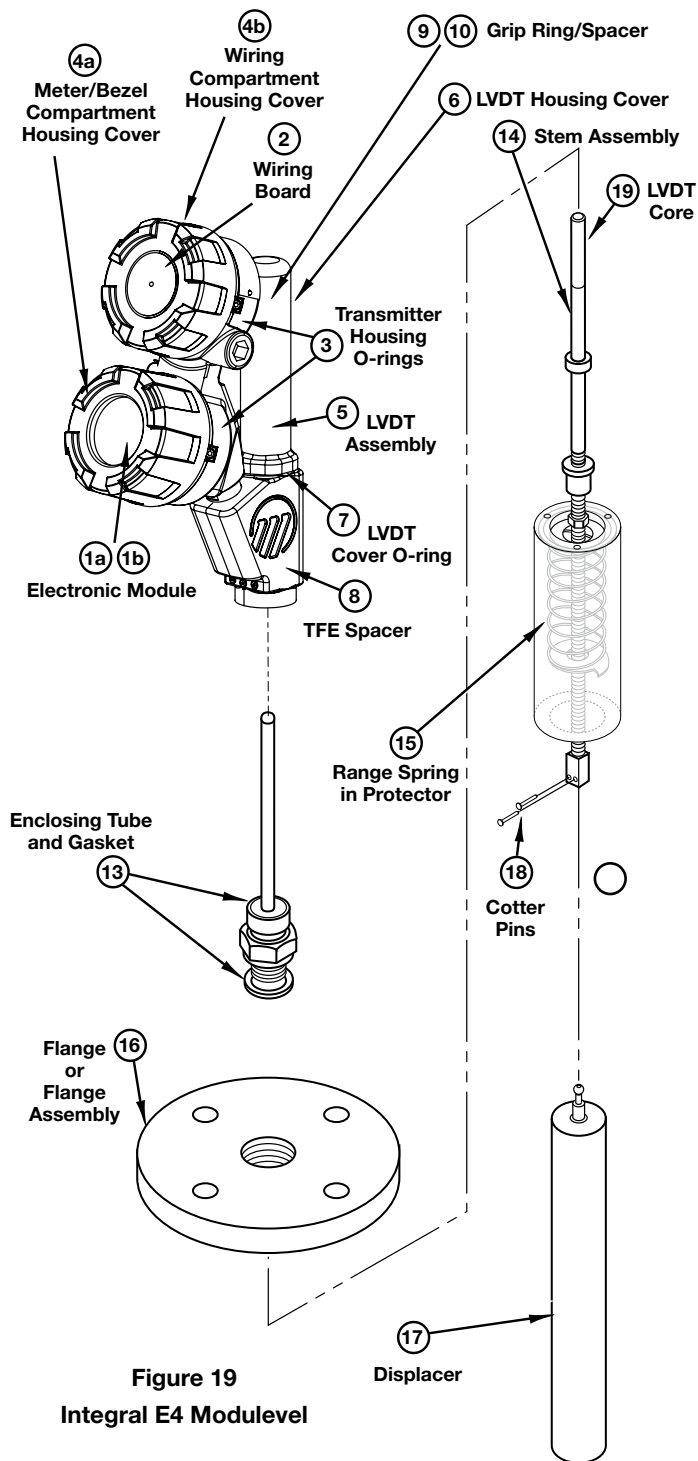

Figure 19
Integral E4 Modulelevel

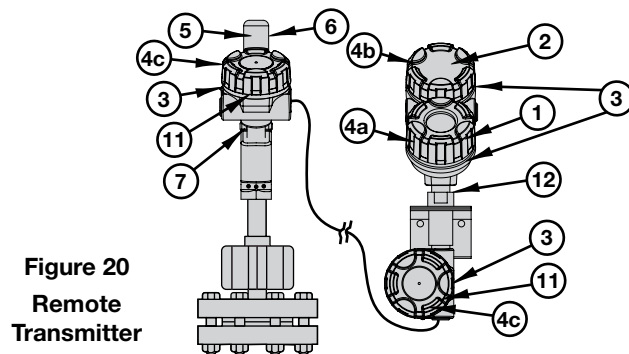

Figure 20
Remote Transmitter

3.6 Specifications

3.6.1 Functional

System Design

Measurement Principle Buoyancy – continuous displacement utilizing a precision range spring

Input

Measured Variable Level, determined by LVDT core movement affected by buoyancy force changes on continuous displacer
Physical Range Up to 300 cm (120") based on displacer length

Output

Type 4 to 20 mA with HART: 3.8 to 20.5 mA usable (per NAMUR NE 43)
Resolution 0.01 mA
Digital Display: 1 mm
Loop Resistance (maximum) 591 ohms @ 24 VDC and 22 mA (see loop resistance chart)
Diagnostic Alarm 3.6, 22 mA or HOLD last output (per NAMUR NE 43)
Damping Adjustable 0-45 seconds

User Interface

Keypad 4-button menu-driven data entry
Display Graphic Liquid Crystal Display
Digital Communication HART Version 7 - with Field Communicator, AMS, or FDT DTM (PACTware), EDDL
Menu Languages Transmitter LCD options: English, French, German, Spanish, Russian, Portuguese, Polish
HART DD options: English, French, German, Spanish, Russian, Portuguese, Polish, Chinese

Power

Voltage (Measured at Instrument Terminals) 11–36 VDC under certain conditions (see transmitter terminal voltage table)

Housing

Material Die-cast aluminum A413 (< 0.4% copper); optional stainless steel
Cable Entry ½" NPT or M20
SIL (Safety Integrity Level) SIL 2 Certified as 1oo1 in accordance with IEC 61508

Displacer Assembly Materials

Flange Carbon steel or 316/316L stainless steel (selectable)
Enclosing tube 316/316L stainless steel
Stem 316/316L stainless steel
Displacer 316/316L stainless steel
Spring Inconel (specific alloy is based on process conditions and model selection)

Process Conditions

Process Temperature Range ① Steam applications: -29 to +260 °C (-20 to +500 °F)
Non-steam applications: -29 to +445 °C (-20 to +835 °F) ②
Process Pressure Range 348 bar @ +38 °C (5050 psig @ +100 °F)

① Maximum process temperatures are based on ambient temperatures less than or equal to +49 °C (+120 °F). Higher ambient temperatures require reduced process temperatures.

② Consult factory for low temperature applications down to -200 °C (-330 °F).

3.6 Specifications

3.6.1 Functional (continued)

Environment

Electronics Operating Temperature	-40 to +80 °C	(-40 to +176 °F)
Display Function Operating Temperature	-20 to +70 °C	(-5 to +160 °F)
Storage Temperature	-40 to +85 °C	(-50 to +185 °F)
Humidity	0-99%, non-condensing	
Electromagnetic Compatibility	Meets CE Requirement: EN 61326	
Surge Protection	Meets CE Requirements EN 61326	
Shock Class	ANSI/ISA-S71.03 Class SA1 ③	
Vibration Class	ANSI/ISA-S71.03 Class VC2 ③	
Altitude	≤2000 m	
Pollution Degree	2	

③ With aluminum housing only. Does not apply to models with 316 SS transmitter housings.

3.6.2 Performance – Level

Reference Conditions	Water @ +21 °C (+70 °F) with 356 mm (14") displacer; wet calibration	
Linearity	±0.50% of full span	
Repeatability	±0.20% of full span	
Ambient temperature effect	Maximum zero shift is 0.017%/°F over ambient temperature range	
Operating Temp. range:	-40 to +80 °C (-40 to +176 °F)	
LCD Temp. Range:	-20 to +70 °C (-5 to +160 °F)	
Hysteresis	±0.20% of full span	
Response Time	<1 second	
Initialization Time	<5 seconds	

3.6.3 Performance – Interface Level & Specific Gravity ④

Linearity	±0.70% of full span	
Repeatability	±0.40% of full span	
Ambient Temperature Effect	Maximum zero shift is 0.017%/°F over ambient temperature range	

④ The displacer must always be completely immersed in process liquid when the E4 is used in interface or density service. Top mounted models require liquid level to exceed the top of the displacer by 51 mm (2") at all times to ensure optimal performance.

3.6.4 Loop Resistance

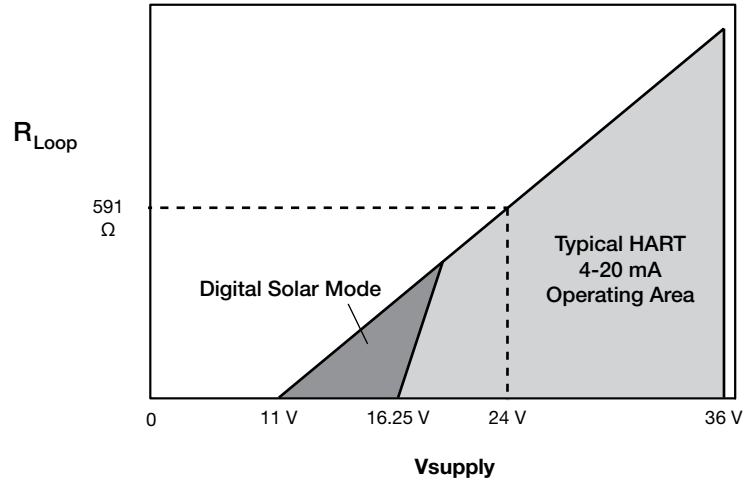

Figure 21
Safe Operating Area

3.6.5 Transmitter Terminal Voltage

Operational Mode	Current Consumption	Vmin	Vmax
HART			
General Purpose	4mA 20mA	16.25V 11V	36V 36V
Intrinsically Safe	4mA 20mA	16.25V 11V	28.6V 28.6V
Explosion Proof	4mA 20mA	16.25V 11V	36V 36V
Fixed Current-Solar Power Operation (PV transmitted via HART)			
General Purpose	10mA ①	11V	36V
Intrinsically Safe	10mA ①	11V	28.6V
HART Multi-Drop Mode (Fixed Current)			
Standard	4mA ①	18V ②	36V
Intrinsically Safe	4mA ①	18V ②	28.6V

① Start-up current 12 mA minimum.

② Allows for loop resistance of at least 250 ohms.

3.6.6 Physical – E4 Module Level Dimensions – Inches (mm)

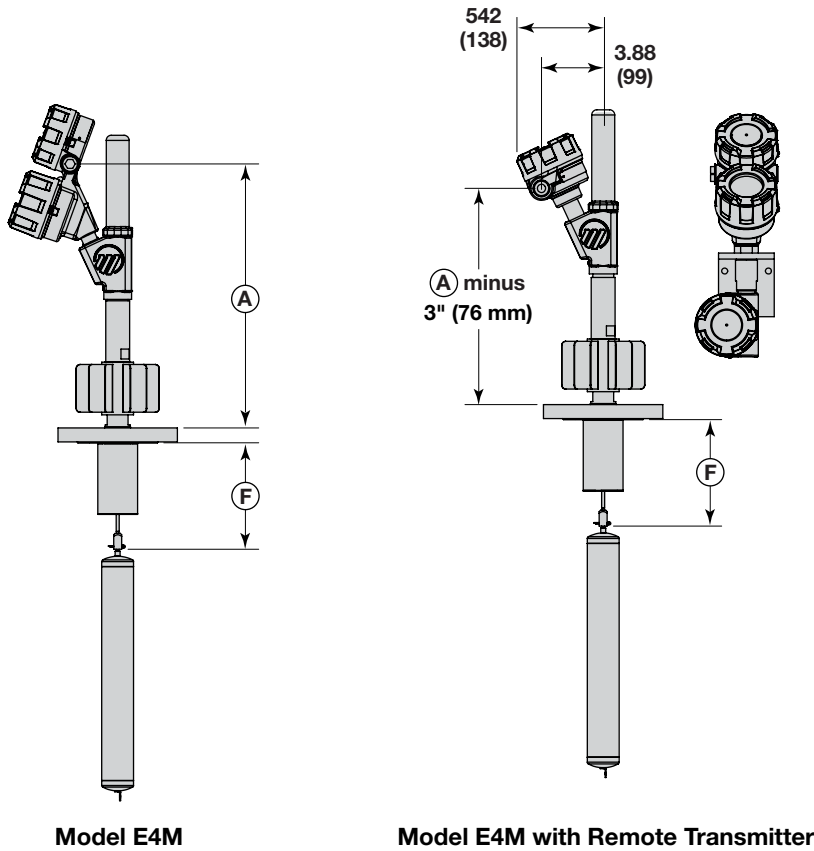

Digit 9	Dim A
A	12.58 (319.5)
B, C	16.58 (421.1)
D, E, H	20.58 (522.7)
F, G, J	24.58 (624.3)

Digits			Dim F
10th	12th	15th	
0	3, 4, 5, K, A, C, D, E W, Z	A	8.69 (220.7)
		B	8.88 (226.6)
		C	9.25 (235)
		D	9.25 (235)
		E	9.19 (233.4)
		F	9.19 (233.4)
		G	9.19 (233.4)
		H	9.38 (238.3)
		I	9.38 (238.3)
1	3, 4, 5, K, A, C, D, E W, Z	A	6.69 (169.9)
		B	6.88 (174.8)
		C	7.25 (184.2)
		D	7.25 (184.2)
		E	7.19 (182.6)
		F	7.19 (182.6)
		G	7.19 (182.6)
		H	7.38 (187.5)
		I	7.38 (187.5)
2	3, 4, 5, K, A, C, D, E W, Z	A	6.69 (169.9)
		B	6.88 (174.8)
		C	7.25 (184.2)
		D	7.25 (184.2)
		E	7.19 (182.6)
		F	7.19 (182.6)
		G	7.19 (182.6)
		H	7.38 (187.5)
		I	7.38 (187.5)
3	6, 7, 8, F, G, H, J, L, M, N	A	8.81 (223.8)
		B	8.94 (227.1)
		C	8.94 (227.1)
		D	8.94 (227.1)

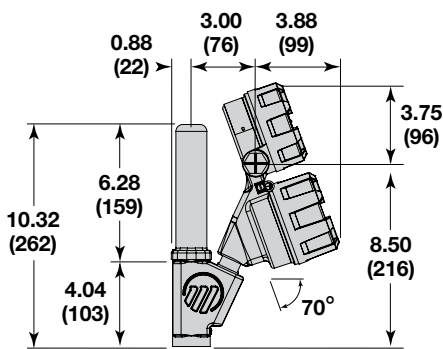

Integral Transmitter Head

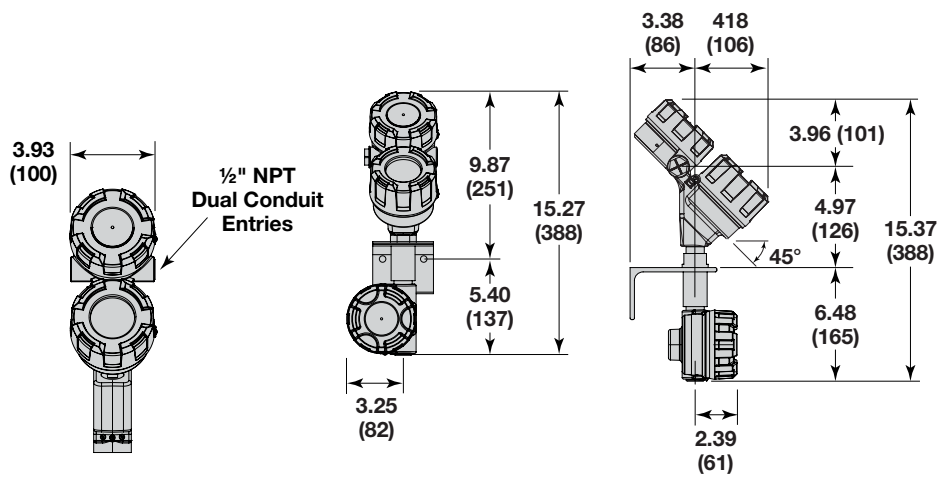

Remote Transmitter Head

3.6.7 Physical – E4 Chamber Dimensions – inches (mm)

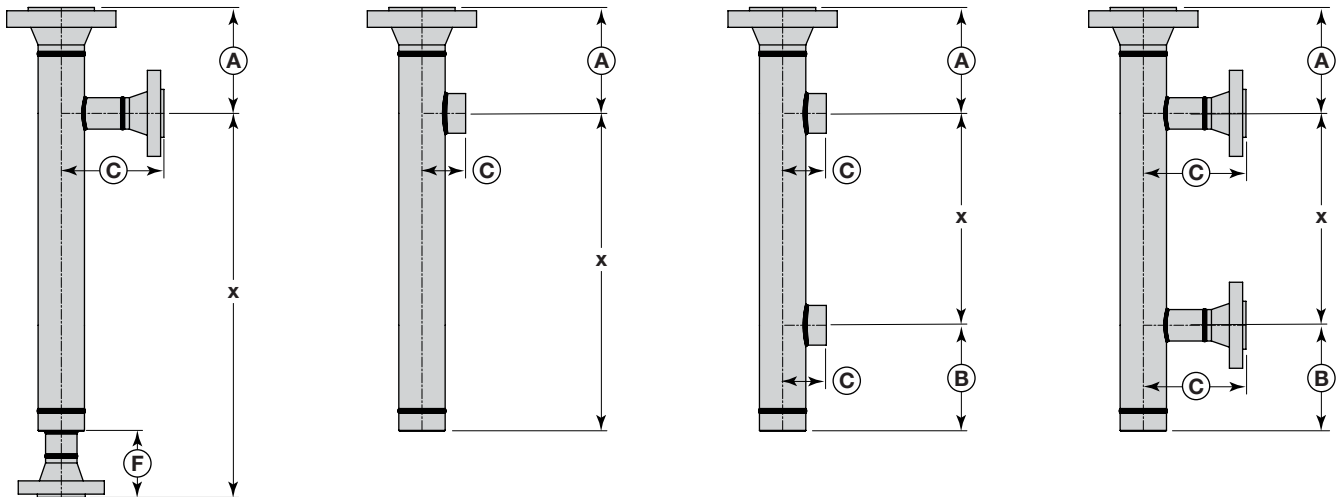

Dim		150#	300#	600#	900#	1500#	2500#
		PN25	PN40	PN100	PN160	PN250	PN320
A	Digit 16 = 'R'	7.31 (186)	7.31 (186)	7.31 (186)	N/A	N/A	N/A
	Digit 16 = 'S'	9.31 (236)	9.31 (236)	9.31 (236)	9.31 (236)	9.31 (236)	9.31 (236)
	Digit 16 = 'T'	12.62 (321)	12.62 (321)	12.62 (321)	12.62 (321)	12.62 (321)	12.62 (321)
B	Side/side only	6.00 (152)	6.00 (152)	6.00 (152)	6.00 (152)	6.00 (152)	6.00 (152)
C	Flanged (SO)	6.12 (155)	6.12 (155)	6.12 (155)	6.12 (155)	6.12 (155)	N/A
	Flanged (WN) - 1½"	6.27 (159)	6.52 (166)	6.83 (173)	6.64 (169)	7.33 (186)	8.46 (215)
	Flanged (WN) - 2"	6.33 (161)	6.58 (167)	6.96 (177)	7.58 (193)	8.27 (210)	9.27 (235)
	Flanged (WN) - DN40	5.60 (142)	5.60 (142)	6.27 (159)	5.66 (144)	6.98 (177)	7.30 (185)
	Flanged (WN) - DN50	5.69 (145)	5.69 (145)	6.51 (165)	6.28 (160)	7.37 (187)	7.96 (202)
	NPT-F 1½"	2.98 (76)	2.98 (76)	2.98 (76)	3.19 (81)	3.19 (81)	C/F
	NPT-F 2"	2.96 (75)	2.96 (75)	2.96 (75)	3.19 (81)	3.19 (81)	C/F
	SW 1½"	3.36 (85)	3.36 (85)	3.36 (85)	3.19 (81)	3.19 (81)	C/F
SW 2"	3.71 (94)	3.71 (94)	3.71 (94)	3.19 (81)	3.19 (81)	C/F	
F	Flanged Side/bottom	6.00 (152)	6.00 (152)	6.00 (152)	8.00 (203)	8.00 (203)	10.00 (254)
	NPT/SW Side/bottom	0.00	0.00	0.00	0.00	0.00	0.00

X for SIDE/SIDE = Level Range

X for SIDE/BOTTOM = Level Range + 4.00" + 'DIM F'

3.7 Model Number

3.7.1 E4 Transmitter with Displacer Assembly

DESIGN TYPE

E 4 M	E4 Modulelevel — Liquid Level Displacer Transmitter
--------------	---

POWER

5	24 VDC, Two-Wire
----------	------------------

SIGNAL OUTPUT

1	4–20 mA with HART, SIL 2 Certified
----------	------------------------------------

ACCESSORIES

0	No Digital Display or Keypad; No other accessories included
1	No Digital Display or Keypad; Adjustable displacer hanger cable included (8' / 2.5m standard)
2	No Digital Display or Keypad; External Chamber included ① ②
A	Digital Display and Keypad included; No other accessories included
B	Digital Display and Keypad included; Adjustable displacer hanger cable included (8' / 2.5m standard)
C	Digital Display and Keypad included; External Chamber included ① ②

① Hanger cable is not necessary for planned installation into external chamber.

② Select chamber model number separately. See Universal Chamber bulletin 41-143.

CLASSIFICATION

0	General Purpose, Weatherproof (IP66 & IP67)
1	Intrinsically Safe (Ex ia & Ex ic)
3	Explosion Proof / Flameproof (Ex db)
C	Non-Incendive
D	Dust Ignition Proof

HOUSING / CONDUIT CONNECTION ③

0	Integral Aluminum enclosure; ½" NPT
1	Integral Aluminum enclosure; M20 × 1.5
2	Integral SST enclosure; ½" NPT
3	Integral SST enclosure; M20 × 1.5
A	Remote Aluminum enclosure; ½" NPT ④
B	Remote Aluminum enclosure; M20 × 1.5 ④
C	Remote SST enclosure; ½" NPT ④
D	Remote SST enclosure; M20 × 1.5 ④

③ Sunshade available and sold separately.

④ Remote transmitter cable sold separately.

PROCESS TEMPERATURE

For Non-Steam (Non-Condensing) Applications	
A	Up to 150 °C; no heat extension
B	Up to 200 °C; 4" finned heat extension
D	Up to 230 °C; 4" plain + 4" finned heat extension
G	Up to 290 °C; 8" plain + 4" finned heat extension
H	Up to 315 °C; 4" plain + 4" finned heat extension
J	Up to 445 °C; 8" plain + 4" finned heat extension ⑤
For Steam (Condensing) Applications	
A	Up to 150 °C; no heat extension
C	Up to 200 °C; 4" finned heat extension
E	Up to 230 °C; 4" plain + 4" finned heat extension
F	Up to 260 °C; 8" plain + 4" finned heat extension

⑤ Remote enclosure only; Available only with Digit 10 = 1 (0.55-1.09 S.G.)

E	4	M	—	5	1			—				—				
----------	----------	----------	---	----------	----------	--	--	---	--	--	--	---	--	--	--	--

3.7 Model Number

3.7.1 E4 Transmitter with Displacer Assembly

SPECIFIC GRAVITY – LIQUID

0	0.23–0.54 ⑥
1	0.55–1.09
2	1.10–2.20 ⑥
9	Custom

⑥ Up to 600# / PN 100 pressure class

PROCESS CONNECTION – HEAD FLANGE ⑦

ASME FLANGES

5 3	3"	150# ASME RF
5 4	3"	300# ASME RF
5 5	3"	600# ASME RF
5 6	3"	900# ASME RF
5 7	3"	1500# ASME RF
5 K	3"	600# ASME RTJ
5 L	3"	900# ASME RTJ
5 M	3"	1500# ASME RTJ

6 3	4"	150# ASME RF
6 4	4"	300# ASME RF
6 5	4"	600# ASME RF
6 6	4"	900# ASME RF
6 7	4"	1500# ASME RF
6 8	4"	2500# ASME RF
6 K	4"	600# ASME RTJ
6 L	4"	900# ASME RTJ
6 M	4"	1500# ASME RTJ
6 N	4"	2500# ASME RTJ

7 3	6"	150# ASME RF
7 4	6"	300# ASME RF
7 5	6"	600# ASME RF
7 6	6"	900# ASME RF
7 7	6"	1500# ASME RF
7 8	6"	2500# ASME RT
7 K	6"	600# ASME RTJ

EN FLANGES

E D	DN 80, PN 63	EN 1092-1 TYPE B2
E E	DN 80, PN 100	EN 1092-1 TYPE B2
E F	DN 80, PN 160	EN 1092-1 TYPE B2
E G	DN 80, PN 250	EN 1092-1 TYPE B2
E H	DN 80, PN 320	EN 1092-1 TYPE B2
E W	DN 80, PN 16	EN 1092-1 TYPE B1
E Z	DN 80, PN 25/40	EN 1092-1 TYPE B1
F D	DN 100, PN 63	EN 1092-1 TYPE B2
F E	DN 100, PN 100	EN 1092-1 TYPE B2
F F	DN 100, PN 160	EN 1092-1 TYPE B2

F G	DN 100, PN 250	EN 1092-1 TYPE B2
F H	DN 100, PN 320	EN 1092-1 TYPE B2
F J	DN 100, PN 400	EN 1092-1 TYPE B2
F W	DN 100, PN 16	EN 1092-1 TYPE B1
F Z	DN 100, PN 25/40	EN 1092-1 TYPE B1
G D	DN 150, PN 63	EN 1092-1 TYPE B2
G E	DN 150, PN 100	EN 1092-1 TYPE B2
G W	DN 150, PN 16	EN 1092-1 TYPE B1
G Z	DN 150, PN 25/40	EN 1092-1 TYPE B1

⑦ If installing Modulevel into Magnetrol/Orion external chamber, select 3" (DN 80) up to 1500# (PN 250) construction & 4" (DN 100) up to 2500# (PN 400)

CONSTRUCTION CODES

0	Industrial
K	ASME B31.1
L	ASME B31.3
M	ASME B31.3 & NACE MR0175/MR0103
N	NACE MR0175/MR0103

MATERIAL OF CONSTRUCTION (E-TUBE/FLANGE/STEM/DISPLACER/HANGER CABLE)

A	316 SST flange, e-tube, stem, displacer and cable assembly (if applicable) ⑧
R	Carbon Steel flange; 316 SST e-tube, stem, displacer and cable assembly (if applicable)

⑧ Consult factory for 1500# (PN 250) construction or greater.

LEVEL RANGE/ DISPLACER LENGTH mm (inches)

All Pressures	
A	356 (14)
B	813 (32)
C	1219 (48)
D	1524 (60)
≤600# (PN 100)	
E	1829 (72)
F	2134 (84)
G	2438 (96)
H	2743 (108)
I	3048 (120)

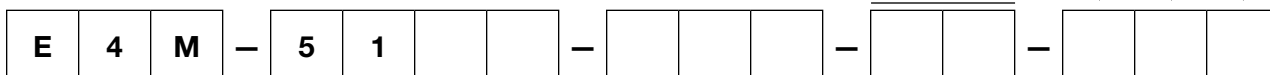

3.7 Model Number

3.7.2 E4 Transmitter Only

DESIGN TYPE

E 4 T	E4 Modulelevel – Transmitter Only
--------------	-----------------------------------

POWER

5	24 VDC, Two-Wire
----------	------------------

SIGNAL OUTPUT

1	4–20 mA with HART, SIL 2 Certified
----------	------------------------------------

ACCESSORIES

0	No Digital Display or Keypad
A	Digital Display and Keypad included

CLASSIFICATION

0	General Purpose, Weatherproof (IP66 & IP67)
1	Intrinsically Safe (Ex ia & Ex ic)
3	Explosion Proof / Flameproof (Ex db)
C	Non-Incendive
D	Dust Ignition Proof

HOUSING / CONDUIT CONNECTION ^①

0	Integral Aluminum enclosure; ½" NPT
1	Integral Aluminum enclosure; M20 × 1.5
2	Integral SST enclosure; ½" NPT
3	Integral SST enclosure; M20 × 1.5
A	Remote Aluminum enclosure; ½" NPT ^②
B	Remote Aluminum enclosure; M20 × 1.5 ^②
C	Remote SST enclosure; ½" NPT ^②
D	Remote SST enclosure; M20 × 1.5 ^②

^① Sunshade available and sold separately.

^② Remote transmitter cable sold separately.

PROCESS TEMPERATURE ^③

For Non-Steam (Non-Condensing) Applications	
G	Up to 290 °C
J	Up to 445 °C
For Steam (Condensing) Applications	
A	Up to 150 °C
E	Up to 230 °C
F	Up to 260 °C

^③ Actual maximum temperature is based on existing field installation, including heat extensions and integral or remote electronics. Reference E4M Process Temperature digits to verify transmitter meets application requirement.

SPECIFIC GRAVITY – LIQUID

0	0.23–0.54
1	0.55–1.09
2	1.10–2.20
9	Custom

E	4	T	-	5	1			-			
----------	----------	----------	---	----------	----------	--	--	---	--	--	--

3.7 Model Number

3.7.3 E4 Connecting Cable

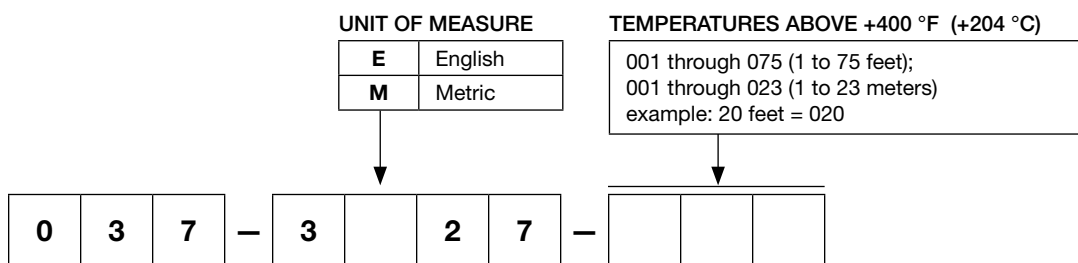
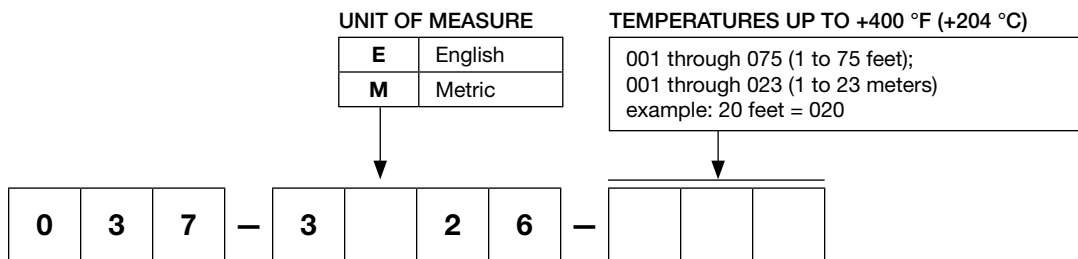

Service Policy

Owners of AMETEK LMS controls may request the return of a control or any part of a control for complete rebuilding or replacement. They will be rebuilt or replaced promptly. Controls returned under our service policy must be returned by Prepaid transportation. Magnetrol will repair or replace the control at no cost to the purchaser (or owner) other than transportation if:

1. Returned within the warranty period; and
2. The factory inspection finds the cause of the claim to be covered under the warranty.

If the trouble is the result of conditions beyond our control; or, is NOT covered by the warranty, there will be charges for labor and the parts required to rebuild or replace the equipment.

In some cases it may be expedient to ship replacement parts; or, in extreme cases a complete new control, to replace the original equipment before it is returned. If this is desired, notify the factory of both the model and serial numbers of the control to be replaced. In such cases, credit for the materials returned will be determined on the basis of the applicability of our warranty.

No claims for misapplication, labor, direct or consequential damage will be allowed.

Return Material Procedure

So that we may efficiently process any materials that are returned, it is essential that a "Return Material Authorization" (RMA) number be obtained from the factory, prior to the material's return. This is available through an AMETEK LMSlocal representative or by contacting the factory. Please provide the following information:

1. Company Name
2. Description of Material
3. Serial Number
4. Reason for Return
5. Application

Any unit that was used in a process must be properly cleaned in accordance with OSHA standards, before it is returned to the factory.

A Material Safety Data Sheet (MSDS) must accompany material that was used in any media.

All shipments returned to the factory must be by prepaid transportation.

All replacements will be shipped F.O.B. factory.

NOTE: See Electrostatic Discharge Handling Procedure on page 8.

NOTE: If unit needs to be returned, the displacer must be secured to prevent damage in transit.

