

# F50

## Globe valve type flow switch

### INSTRUCTION MANUAL AND PARTS LIST

#### DESCRIPTION

The model F50 control is a globe valve type flow switch designed for installation in 3/4" through 2" horizontal pipelines.

#### UNPACKING

Unpack the instrument carefully. Inspect all units for damage. Report any concealed damage to the carrier within 24 hours. Check the contents of the packing slip and purchase order and report any discrepancies to the factory. Check and record the serial number for future reference when ordering parts.

#### MODEL IDENTIFICATION

F50 is identified by a ten digit alpha-numeric part number system. The part number specifies exact unit configuration, material, pipe size and other options.



#### SELECTION DATA

A complete F50 flow switch, consists of 1 order code:

F 5 0	Mechanical globe valve type switch.
-------	-------------------------------------

#### MATERIALS OF CONSTRUCTION & PIPE LINE SIZE

1	Bronze body with 300 SST trim and 400 SST magnetic sleeve.
4	316 SST body with 316 SST trim and magnetic sleeve.

#### PIPE SIZE CONNECTION

A 2	3/4" NPT
B 2	1" NPT
C 2	1 1/2" NPT
D 2	2" NPT

#### ACTUATING FLOW RATE m<sup>3</sup>/h WATER FLOW

- increasing rate -						Pipe size
A	B	C	D	E	F	NPT
N/A	0.25	0.36	0.52	0.77	1.11	3/4"
0.23	0.39	0.57	0.84	1.25	1.61	1"
0.30	0.61	1.07	1.73	2.79	4.79	1 1/2"
0.43	0.70	1.16	1.91	3.25	5.63	2"
- decreasing rate -						
N/A	0.18	0.27	0.41	0.59	0.84	3/4"
0.18	0.32	0.48	0.68	1.02	1.32	1"
0.25	0.52	0.91	1.48	2.38	4.06	1 1/2"
0.36	0.61	0.98	1.61	2.75	4.77	2"

Switch mechanism & enclosure, refer to switch mechanism bulletin, furnished with your control.

F	5	0							
---	---	---	--	--	--	--	--	--	--

complete order code for F50 flow switch

## PRINCIPLE OF OPERATION

Diagrams A and B illustrate the simple and foolproof Magnetrol operating principle. Switching action is obtained through the use of a magnetic attraction sleeve, actuated by a flow sensing disc, and a switching mechanism. These two basic component assemblies are separated by a non-magnetic, pressure tight enclosing tube. The mercury switch and magnet are assembled to a swinging arm which operates on precision stainless steel pivot pins.

## OPERATING CYCLE

On an increasing flow rate, the flow disc moves the attraction sleeve up within the field of a switch magnet, drawing it in, tightly to the enclosing tube. This causes the mercury switch to tilt, "making" or "breaking" an electrical circuit. When the flow rate drops below the rate for which the flow disc is calibrated, the attraction sleeve is pulled downward until, at a predetermined low flow rate, the switch magnet releases and swings outward away from the enclosing tube. This in turn tilts the mercury switch in an opposite direction, causing a reversal of the switching action.

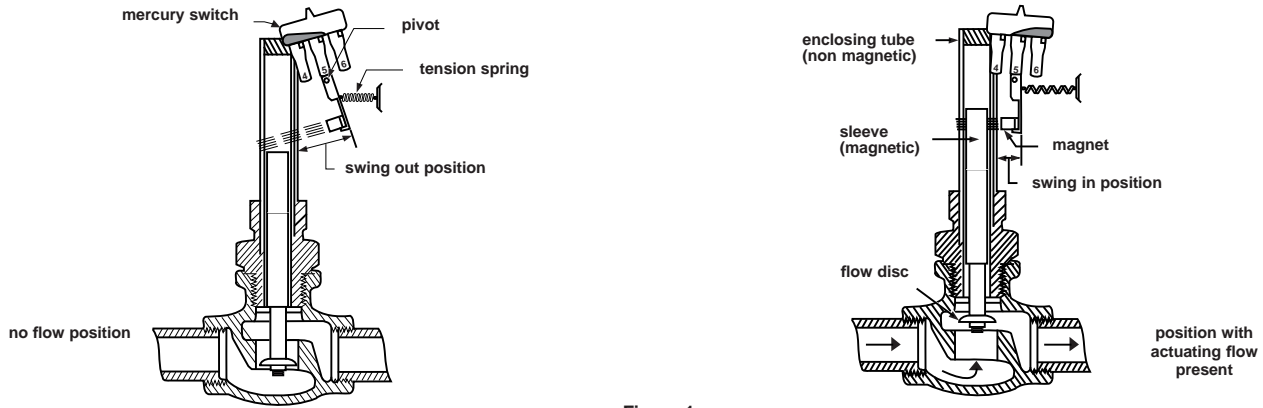

Figure 1

## REPLACEMENT PARTS

Item no.	Description	Bronze body				Stainless steel body			
		3/4"	1"	1 1/2"	2"	3/4"	1"	1 1/2"	2"
1	Housing cover	See bulletin 42-780 for switch housing replacement assemblies. On flow switches with pneumatic switching, consult bulletin on mechanism furnished for special housing base assemblies.							
2	Housing base								
3	Switch mechanism	See bulletin 42-120 for switch mechanism furnished.							
4	Switch								
5	Enclosing tube BASEEFA & CENELEC	32-6325-001				32-6325-002			
		32-6344-002				32-6344-001			
6	E-tube gasket	12-1301-002				12-1204-001			
7	O ring (not shown)	-		12-2201-226		-		12-1204-036	
8	Body adaptor (not shown)	-		04-5386-001		-		04-0481-001	
9	Threaded body	02-5703-003	02-5703-004	02-5705-003	02-5705-004	02-5703-001	02-5703-002	02-5705-001	02-5705-002
10	Flow piston stop	05-5420-121		-		05-5420-121		-	
11	Flow piston ass. ①	32-7127-001	32-7127-003	32-7127-002		32-7108-001	32-7109-001	32-7109-002	
12	Lock nut ②	10-2107-002	10-2107-003			10-2107-002	10-2107-003		
13	Flow disc ③	Specify complete model number.							

① Highly corrosive applications use piston assembly with sheathed attraction sleeve. Consult local representative for ordering assistance.

② Use insoluble adhesive on nut when attaching new flow disc.

③ When actuated flow rate is critical, the entire control MUST be returned to the factory for replacement and recalibration of flow disc.

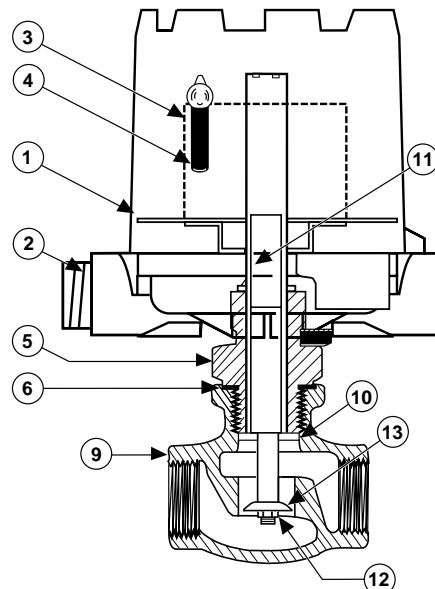

### IMPORTANT:

When ordering, please specify:

- A. Model and serial number of control.
- B. Name and number of replacement part.

# GENERAL INFORMATION

## PIPING

The model F50 flow switch should be located in a horizontal pipe run, with the arrow on the valve body, pointing in the direction of flow. The switch housing must always be above the valve body.

1. When installing, use wrenches on valve body only. Do NOT attempt to tighten or draw-up valve body on the pipe by pulling or pushing on switch housing cover.
2. Adjust pipe alignment as required to bring switch housing to a vertical position above pipeline. Magnetrol flow switches must be mounted within three (3°) degrees of vertical. Three degree slant is noticeable by the eye, but installation should be checked with a level on the side of the switch housing cover, at two places, 90° apart.

*NOTE: On flow switches using pneumatic switch assemblies, consult bulletin on mechanism furnished for air (or gas) piping instructions.*

## WIRING

*NOTE: All model F50 switch housings are designed to allow 360° positioning of the conduit outlet by loosening the set screw(s) located under the housing base.*

1. On high temperature applications [above 120°C (250°F) in pipeline], high temperature insulated wire should be used between the Magnetrol F50 and the first junction box located in a cooler area.
2. To gain access to the switch mechanism, remove switch housing cover.
3. Pull in supply wires (conductors), wrap around enclosing tube underneath the baffle plate and connect to proper terminals. Be certain that excess wire does not interfere with "tilt" of switch and that adequate clearance exists for replacement of switch housing cover.

*NOTE: See switch mechanism bulletin which is furnished with your control, for proper connections.*

Switch mechanism	Series ref.
Standard mercury switches	A, 3
Anti-vibration mercury switch	E, 2
Dry contact switches	B, C, D, U
Hermetically sealed switch	W, X
Bleed type pneumatic switch	J
Non-bleed type pneumatic switch	K

4. Connect power supply to the F50 and test switch actuation by varying flow rate within pipeline.

*NOTE: If the switch mechanism fails to function properly, check vertical alignment of control housing and refer to installation bulletin on mechanism furnished, as listed above.*

5. Replace switch housing cover and place flow switch into service.

## SPECIFIC GRAVITY CORRECTION

To determine the actuating flow rates for liquids, other than water (approximate viscosity of 20 centistokes or less), a specific gravity correction factor must be applied to the water flow rates given in the table.

*Example:* A 2" NPT size model F50, with size 'C' flow disc, actuates with water flow rates of 1.16 m<sup>3</sup>/h (5.1 GPM) increasing flow and 0.98 m<sup>3</sup>/h (4.3 GPM) decreasing flow.

Then, used with a hydrocarbon liquid of 0.60 specific gravity (1.33 multiplication factor), the actuating flow rates are 1.54 m<sup>3</sup>/h (6.8 GPM) increasing and 1.30 m<sup>3</sup>/h (5.7 GPM) decreasing flow.

### Specific gravity correction chart

Specific gravity	Multiplication factor	Specific gravity	Multiplication factor
0.40	1.65	0.95	1.03
0.45	1.55	1.00	1.00
0.50	1.46	1.05	0.97
0.55	1.39	1.10	0.95
0.60	1.33	1.15	0.92
0.65	1.27	1.20	0.90
0.70	1.22	1.25	0.88
0.75	1.17	1.30	0.86
0.80	1.13	1.35	0.84
0.85	1.10	1.40	0.82
0.90	1.06	1.45	0.80

# DIMENSIONS IN mm (inches)

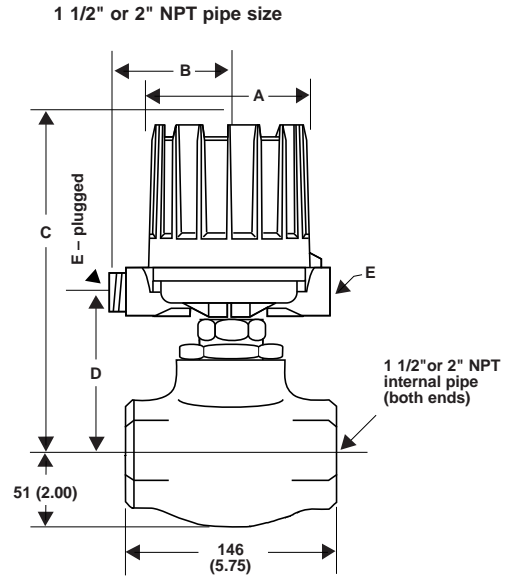
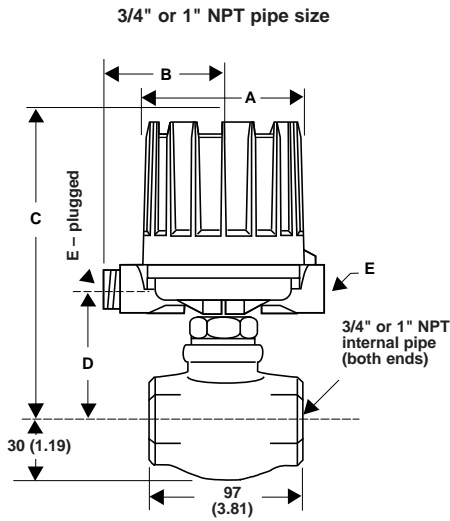

Housing	Outline dimensions					
	A	B	C		D	
			3/4" or 1"	1 1/2" or 2"	3/4" or 1"	1 1/2" or 2"
NEMA 4X (IP 65)	151 (5.93)	109 (4.29)	247 (9.75)	273 (10.75)	91 (3.60)	116 (4.60)
NEMA 7/9 (IP 65)	143 (5.63)	100 (3.94)	243 (9.57)	269 (10.60)	90 (3.54)	116 (4.56)
BASEEFA or CENELEC (IP 66)	143 (5.63)	110 (4.33)	298 (11.73)	324 (12.75)	93 (3.66)	119 (4.68)
NEMA 3R (IP 53)	118 (4.64)	127 (5.00)	214 (8.42)	240 (9.45)	87 (3.45)	113 (4.45)

Electrical connections – E	
<i>Electrical switches:</i>	
NEMA 4X:	1" NPT – M20 x 1,5 – PG 16 (2 entries – 1 plugged)
NEMA 7/9:	1" NPT-F entry
BASEEFA & CENELEC:	M 20 x 1,5 or 3/4" NPT-F entry
<i>Pneumatic switches:</i>	
NEMA 3R: K series	1/4" NPT-F (2 entries)
J series	1/4" NPT-F (1 entry)

**NOTE:** For NEMA 4X/7/9 allow 203 (8.00) overhead clearance for cover removal.

## IMPORTANT

### SERVICE POLICY

Owners of Magnetrol products may request the return of a control; or, any part of a control for complete rebuilding or replacement. They will be rebuilt or replaced promptly. Magnetrol International will repair or replace the control, at no cost to the purchaser, (or owner) **other than transportation cost** if:

- a. Returned within the warranty period; and,
- b. The factory inspection finds the cause of the malfunction to be defective material or workmanship.

If the trouble is the result of conditions beyond our control; or, is **NOT** covered by the warranty, there will be charges for labour and the parts required to rebuild or replace the equipment. In some cases, it may be expedient to ship replacement parts; or, in extreme cases a complete new control, to replace the original equipment before it is returned. If this is desired, notify the factory of both the model and serial numbers of the control to be replaced. In such cases, credit for the materials returned, will be determined on the basis of the applicability of our warranty. No claims for misapplication, labour, direct or consequential damage will be allowed.

### RETURNED MATERIAL PROCEDURE

So that we may efficiently process any materials that are returned, it is essential that a "Return Material Authorisation" (RMA) form will be obtained from the factory. It is mandatory that this form will be attached to each material returned. This form is available through Magnetrol's local representative or by contacting the factory. Please supply the following information:

1. Purchaser Name
2. Description of Material
3. Serial Number
4. Desired Action
5. Reason for Return
6. Process details

All shipments returned to the factory must be by prepaid transportation. Magnetrol **will not accept** collect shipments. All replacements will be shipped FOB factory.

UNDER RESERVE OF MODIFICATIONS

BULLETIN N°: BE 47-603.10  
EFFECTIVE: AUGUST 995  
SUPERSEDES: July 1991



EUROPE

Heikensstraat 6, 9240 Zele Tel. (052) 45.11.11  
e-mail: info.magnetrolbe@ametec.com