

Jupiter[®]

Model JM4

Installation and Operating Manual

Software v1.x

Magnetostrictive Level Transmitter

FOUNDATION fieldbus™

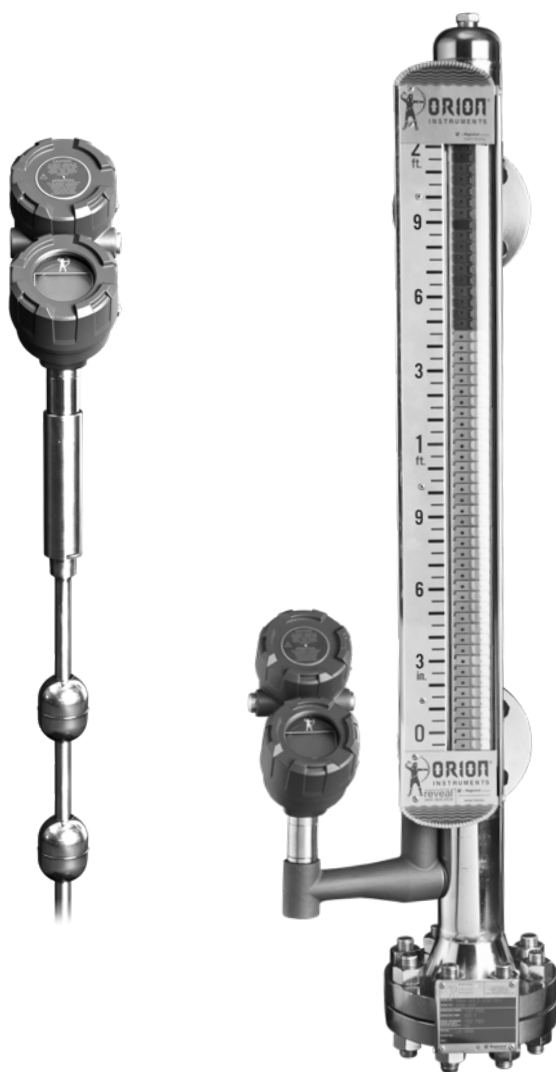
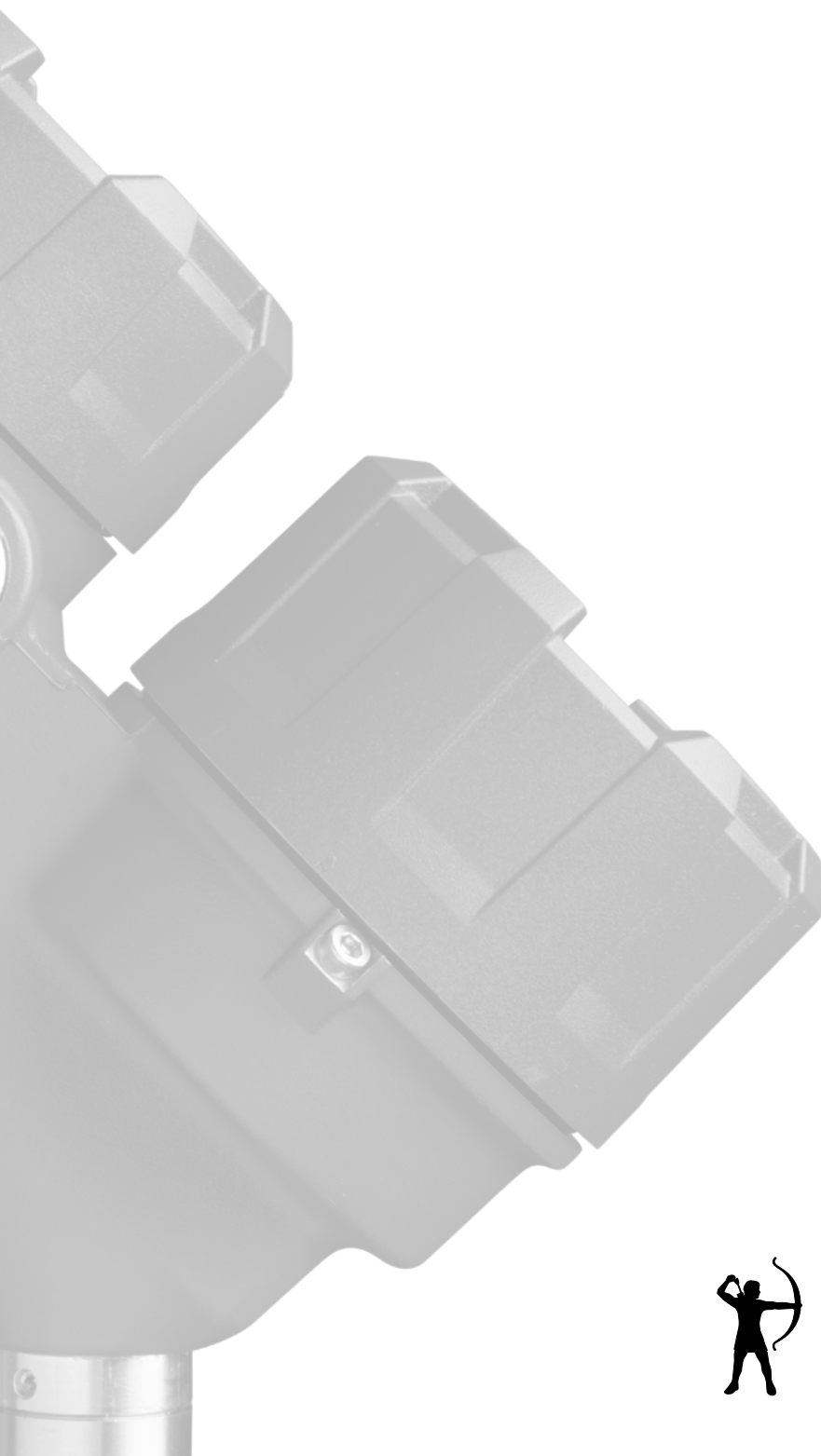

ORION[®]
INSTRUMENTS

AMETEK[®]
LEVEL MEASUREMENT
SOLUTIONS

Read this Manual Before Installing

This manual provides information on the Jupiter® magnetostrictive transmitter. It is important that all instructions are read carefully and followed in sequence. Detailed instructions are included in the Installation section of this manual.

Conventions Used in this Manual

Certain conventions are used in this manual to convey specific types of information. General technical material, support data, and safety information are presented in narrative form. The following styles are used for notes, cautions, and warnings.

Notes

Notes contain information that augments or clarifies an operating step. Notes do not normally contain actions. They follow the procedural steps to which they refer.

Cautions

Cautions alert the technician to special conditions that could injure personnel, damage equipment, or reduce a component's mechanical integrity. Cautions are also used to alert the technician to unsafe practices or the need for special protective equipment or specific materials. In this manual, a caution box indicates a potentially hazardous situation which, if not avoided, may result in minor or moderate injury.

Warnings

Warnings identify potentially dangerous situations or serious hazards. In this manual, a warning indicates an imminently hazardous situation which, if not avoided, could result in serious injury or death.

Safety Messages

Follow all standard industry procedures for servicing electrical equipment when working with or around high voltage. Always shut off the power supply before touching any components.

WARNING! Explosion hazard. Do not connect or disconnect designs rated Explosion proof or Non-incendive unless power has been switched off and/or the area is known to be non-hazardous.

Low Voltage Directive

For use in Installation Category II, Pollution Degree 2. If equipment is used in a manner not specified by the manufacturer, protection provided by the equipment may be impaired.

Warranty

All AMETEK LMS electronic level and flow controls are warranted free of defects in materials or workmanship for eighteen months from the date of original factory shipment.

If returned within the warranty period; and, upon factory inspection of the control, the cause of the claim is determined to be covered under the warranty; then, AMETEK LMS will repair or replace the control at no cost to the purchaser (or owner) other than transportation.

AMETEK LMS shall not be liable for misapplication, labor claims, direct or consequential damage or expense arising from the installation or use of equipment. There are no other warranties expressed or implied, except special written warranties covering some AMETEK LMS products.

Quality Assurance

The quality assurance system in place at AMETEK LMS guarantees the highest level of quality throughout the company. AMETEK LMS is committed to providing full customer satisfaction both in quality products and quality service.

The AMETEK LMS quality assurance system is certified to ISO 9001, affirming our commitment to internationally recognized quality management standards and continuous improvement.

Copyright © 2024 AMETEK Magnetrol USA, LLC

Performance specifications are effective with date of issue and are subject to change without notice. AMETEK LMS reserves the right to make changes to the product described in this manual at any time without notice. AMETEK LMS makes no warranty with respect to the accuracy of the information in this manual.

Jupiter® Model JM4 Magnetostrictive Transmitter with FOUNDATION fieldbus™ Output

Table of Contents

1.0 FOUNDATION fieldbus™ Overview	
1.1 Description	4
1.2 Device Description (DD)	5
1.2.1 FOUNDATION fieldbus™ DD Revision Table	5
1.3 Link Active Scheduler (LAS)	5
1.4 Intrinsic Safety	6
2.0 Installation	
2.1 Installation Prep	6
2.1.1 Factory Mounting & Pre-configuration	6
2.1.2 Unpacking	7
2.1.3 Electrostatic Discharge Handling	7
2.1.4 Site Preparation (Power Supply)	7
2.1.5 Equipment and Tools	7
2.1.6 Remote Mount Transmitter Head	8
2.1.7 Hi-Temp Configurations and Temp Limits	8
2.2 Mounting for External Mount	8
2.2.1 Mounting Transmitter Head	8
2.2.2 Available Configurations	8
2.2.3 Securing the Transmitter to the MLI	9
2.2.4 Installation on Atlas™ vs. Aurora®	10
2.2.5 Insulation	10
2.2.6 Vibration Kit	10
2.3 Mounting for Direct Insertion	11
2.3.1 Available Configurations	11
2.3.2 Float Installation	11
2.3.3 Centering Disc	12
2.4 Wiring	12
2.4.1 General Purpose or Non-Incendive (CI I, Div. 2)	12
2.4.2 Intrinsically Safe	13
2.4.3 Explosion Proof	13
2.5 Configuration	14
2.5.1 Bench Configuration	14
2.5.2 Menu Navigation and Data Entry	14
2.5.2.1 Navigating the Menu	15
2.5.2.2 Data Selection	15
2.5.2.3 Entering Numeric Data Using Digit Entry	15
2.5.2.4 Entering Numeric Data Using Increment/Decrement	16
2.5.2.5 Entering Character Data	16
2.5.3 Password Protection	16
2.5.4 Model JM4 Menu: Step-By-Step Procedure	17
2.5.5 Auto-Configuration/Reset New Probe Diagnostic	19
2.5.6 Configuration Menu — Device Setup	20
3.0 Function Blocks	
3.1 Overview	24
3.1.1 Universal Fieldbus Block Parameters	25
3.2 Resource Block	26
3.2.1 Resource Block Parameters	26
3.2.2 Additional Resource Block Parameters	28
3.3 Transducer Block	30
3.3.1 Transducer Block Parameters	30
3.3.2 Password Parameters	31
3.3.3 Configuration Parameters	31
3.3.4 Device-Specific Configuration Parameters	31
3.4 Analog Input Block	32
3.4.1 AI Block Parameters	32
3.4.2 AI Block Diagnostics	35
3.4.3 Local Display of Analog Input Transducer Block Output	35
3.4.3.1 AI Out Display Screens	36
3.4.4 AI Block Configuration	37
3.4.5 Simulation Feature	38
3.5 PID Block	38
3.5.1 PID Block Parameters	38
4.0 Advanced Function Blocks	
4.1 Integrator Block (IT)	41
4.2 Arithmetic Block (AR)	43
4.3 Input Selector Block (IS)	45
4.4 Signal Characterizer Block (SC)	47
5.0 Reference Information	
5.1 Description	48
5.2 Theory of Operation	48
5.3 Troubleshooting	49
5.3.1 Status Messages	
5.4 Configuration Information	51
5.4.1 Volumetric Capability	51
5.4.1.1 Configuration Using Built-in Vessel Types	51
5.4.1.2 Configuration Using Custom Table	53
5.4.2 Reset Function	54
5.4.3 Additional Diagnostic/Troubleshooting Capabilities	54
5.4.3.1 Event History	54
5.4.3.2 Context-sensitive Help	54
5.4.3.3 Trend Data	54
5.5 Agency Approvals	55
5.5.1 Agency Specifications Drawing	57
5.6 Replacement Parts	58
5.7 Specifications	59
5.7.1 Functional/Physical	59
5.7.2 Physical Specifications – Transmitter	60
5.7.3 Power Supply Requirements	62
5.8 Model Number	63
Appendix A	69

1.0 FOUNDATION fieldbus™ Overview

1.1 Description

FOUNDATION fieldbus™ is a digital communications system that serially interconnects devices in the field. A Fieldbus system is similar to a Distributed Control System (DCS) with two exceptions:

- Although a FOUNDATION fieldbus™ system can use the same physical wiring as an existing 4–20 mA device, Fieldbus devices are not connected point to point, but rather are multidropped and wired in parallel on a single pair of wires (referred to as a segment).
- FOUNDATION fieldbus™ is a system that allows the user to distribute control across a network. Fieldbus devices are smart and actually maintain control over the system.

Unlike 4–20 mA analog installations in which the two wires carry a single variable (the varying 4–20 mA current), a digital communications scheme such as FOUNDATION fieldbus™ considers the two wires as a network. The network can carry many process variables as well as other information. The Jupiter Model JM4 is a FOUNDATION fieldbus™ registered device that communicates with the H1 FOUNDATION fieldbus™ protocol operating at 31.25 kbits/sec. The H1 physical layer is an approved IEC 61158 standard.

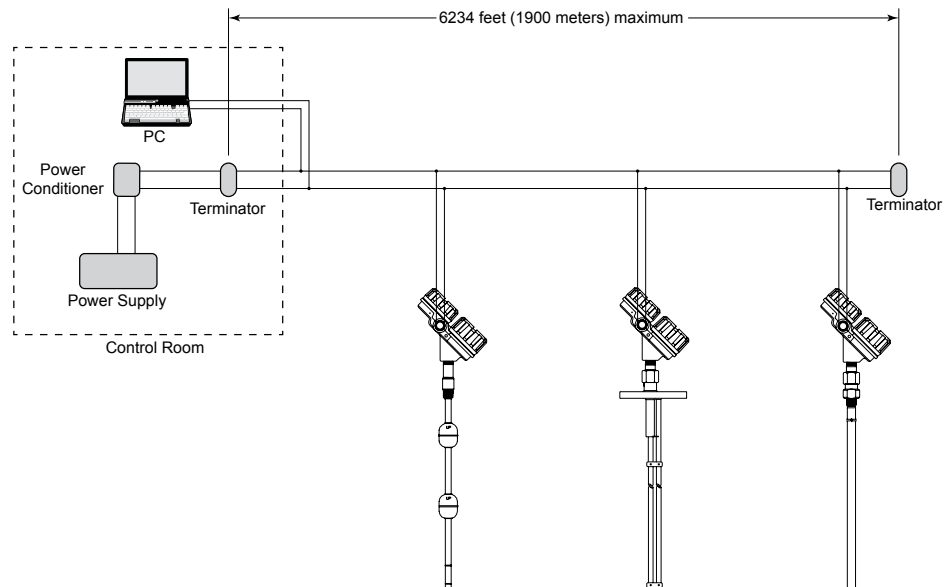

Fig. 1-1. Typical Fieldbus Installation

Details regarding cable specifications, grounding, termination, and other network information can be found in IEC 61158 or the wiring installation application guide AG-140 at www.fieldbus.org.

1.2 Device Description (DD)

An important requirement of Fieldbus devices is the concept of interoperability, defined as “the ability to operate multiple devices in the same system, regardless of manufacturer, without loss of functionality.”

Device Description (DD) technology is used to achieve this interoperability. The DD provides extended descriptions for each object and provides pertinent information needed by the host system. DDs are similar to the drivers that your personal computer (PC) uses to operate peripheral devices connected to it. Any Fieldbus host system can operate with a device if it has the proper DD and Common File Format (CFF) for that device.

The most recent DD and CFF files can be found on the FOUNDATION fieldbus™ web site at www.fieldbus.org or at ametk-measurement.com.

NOTE: Consult your host system vendor for any host-specific files that may be needed.

1.2.1 FOUNDATION fieldbus™ DD Revision Table

Version	Release Date	Compatible with Model JM4 Software
Dev V01 DD V02	February 2015	Version 1.0a or later

1.3 Link Active Scheduler (LAS)

The default operating class of the Jupiter Model JM4FF with FOUNDATION fieldbus™ is a Basic device. However, it is capable of being configured as a Link Active Scheduler (LAS).

The LAS controls all communication on a FOUNDATION fieldbus™ segment. It maintains the “Live List” of all devices on a segment and coordinates both the cyclic and acyclic timing.

The primary LAS is usually maintained in the host system, but in the event of a failure, all associated control can be transferred to a backup LAS in a field device such as the Jupiter® Model JM4 FF.

NOTES:

- 1) The Jupiter Model JM4 is normally shipped from the factory with Device Class set to Basic.
- 2) The operating class can be changed from Basic to LAS using a FOUNDATION fieldbus™ configuration tool.

1.4 Intrinsic Safety

The H1 physical layer supports Intrinsic Safety (IS) applications with bus-powered devices. To accomplish this, an IS barrier or galvanic isolator is placed between the power supply in the safe area and the device in the hazardous area.

H1 also supports the Fieldbus Intrinsically Safe Concept (FISCO) model which allows more field devices in a network. The FISCO model considers the capacitance and inductance of the wiring to be distributed along its entire length. Therefore, the stored energy during a fault will be less and more devices are permitted on a pair of wires. Instead of the conservative entity model, which only allows about 90 mA of current, the FISCO model allows a maximum of 110 mA for Class II C installations and 240 mA for Class II B installations.

FISCO certifying agencies have limited the maximum segment length to 1000 meters because the FISCO model does not rely on standardized ignition curves.

The Jupiter Model JM4 magnetostrictive transmitter is available with entity IS or FISCO IS approvals.

2.0 Installation

Caution: If equipment is used in a manner not specified by manufacturer, protection provided by equipment may be impaired

This section provides detailed procedures for properly installing, wiring, configuring and, if needed, troubleshooting the Jupiter magnetostrictive level transmitter.

In most cases, externally mounted units will be shipped from the factory attached to the Orion Instruments® magnetic level indicator.

2.1 Installation Prep

2.1.1 Factory Mounting & Pre-configuration

All Jupiter Model JM4 transmitters sold with Orion Instruments magnetic level indicators (MLIs) are shipped pre-mounted and pre-configured. The span for 4-20 mA and HART or Foundation fieldbus is set to the span of the process connections on the MLI. For instructions on how to re-configure the transmitter, see Section 2.5 Configuration.

2.1.2 Unpacking

Unpack the instrument carefully. Inspect all units for damage. Report any concealed damage to carrier within 24 hours. Check the contents against the packing slip and purchase order. Check and record the serial number for future reference when ordering parts.

Caution: Do not discard the shipping container until all parts are accounted for and inspected.

2.1.3 Electrostatic Discharge Handling

AMETEK LMS electronic instruments are manufactured to the highest quality standards. These instruments use electronic components that may be damaged by static electricity present in most work environments.

The following steps are recommended to reduce the risk of component failure due to electrostatic discharge.

- Ship and store circuit boards in anti-static bags. If an antistatic bag is not available, wrap the board in aluminum foil. Do not place boards on foam packing materials.
- Use a grounding wrist strap when installing and removing circuit boards. A grounded workstation is recommended.
- Handle circuit boards only by the edges. Do not touch components or connector pins.
- Make sure that all electrical connections are completely made and none are partial or floating. Ground all equipment to a reliable earth ground.

2.1.4 Site Preparation (Power Supply)

Each Jupiter magnetostrictive transmitter is built to match the specifications required within the defined model number. Wiring terminations will need to be made and the configuration will need to be accomplished.

Ensure that the power to be supplied to the instrument is the same voltage (24 VDC) as ordered with the instrument, and that the wiring between the power supply and the Jupiter transmitter is correct for the type of installation.

NOTE: Applying incorrect voltage will damage the unit.

When installing the Jupiter transmitter in a general purpose or hazardous area, all local, state, and federal regulations and guidelines must be observed. See *Wiring, Section 2.4*.

2.1.5 Equipment and Tools

To attach a Jupiter transmitter to an existing MLI or direct insertion model, you may need the following tools:

- $\frac{5}{16}$ " Nut-Driver (for tightening the mounting clamps)



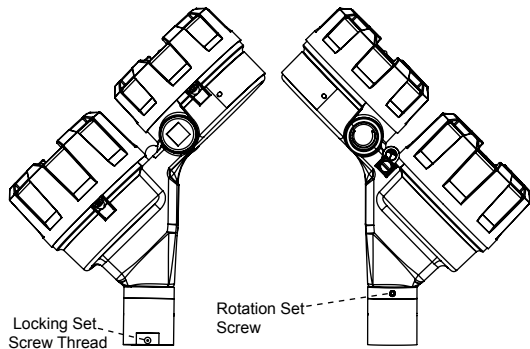

Fig. 2-1. Side Views of Transmitter Head

- Screwdriver and assorted hand tools for making conduit and electrical connections.
- Tape measure or ruler if configuring via Set 4 mA and Set 20 mA display screens.
- Digital multimeter or DVM to troubleshoot supply voltage problems.
- 2.5 mm Allen key to tighten transmitter to probe connection.

2.1.6 Remote Mount Transmitter Head

For applications with possible clearance or transmitter accessibility issues, the JM4 is available with a remote mount transmitter head. This transmitter head comes with a 3 or 12 ft (0.91 or 3.66 m) heavily shielded cable and can be mounted onto nearby objects.

NOTE: Not available for explosion proof units.

2.1.7 Hi-Temp Configurations and Temp Limits

The hi-temp JM4 transmitter is capable of operating in process temperatures between -50 and +800 °F (-46 to +427 °C). Keep in mind that the hi-temp JM4 has a neck extending 9¼" (23.5 cm) from the probe to the transmitter head (as opposed to 5¼" or 13.3 cm for the standard JM4), so height restrictions should be considered before installing.

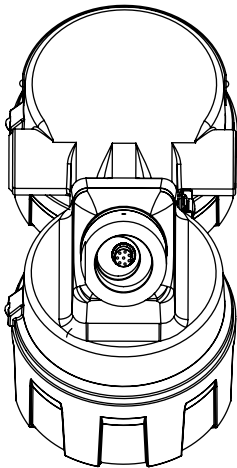

Fig. 2-2. Transmitter Head Connection From Below

2.2 Mounting for External Mount

2.2.1 Mounting Transmitter Head

To attach the JM4 transmitter head to the probe, place the female transmitter connection over the male probe connection, and rotate until the pins slide into place. Use a 2.5 mm Allen key to hand tighten locking set screws (Figure 2-1) to secure the transmitter head in place. Once secured, rotate display until its in the desired position. If transmitter head rotation is not desired, tighten the rotation set screw, also with a 2.5 mm Allen key.

2.2.2 Available Configurations

The externally mounted Jupiter Model JM4 transmitter is available with a variety of configurations and mounting options. These include (in order from left to right in Fig. 2-4) top-mount, top-mount offset, bottom-mount offset. All of these configurations are available with one or two magnetic floats (two floats are necessary to measure total AND interface level).

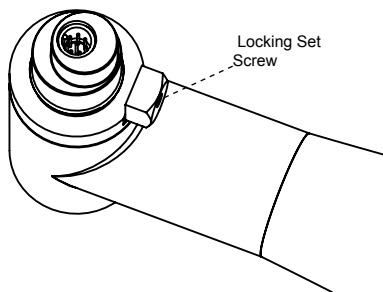

Fig. 2-3. Probe Connection From Above

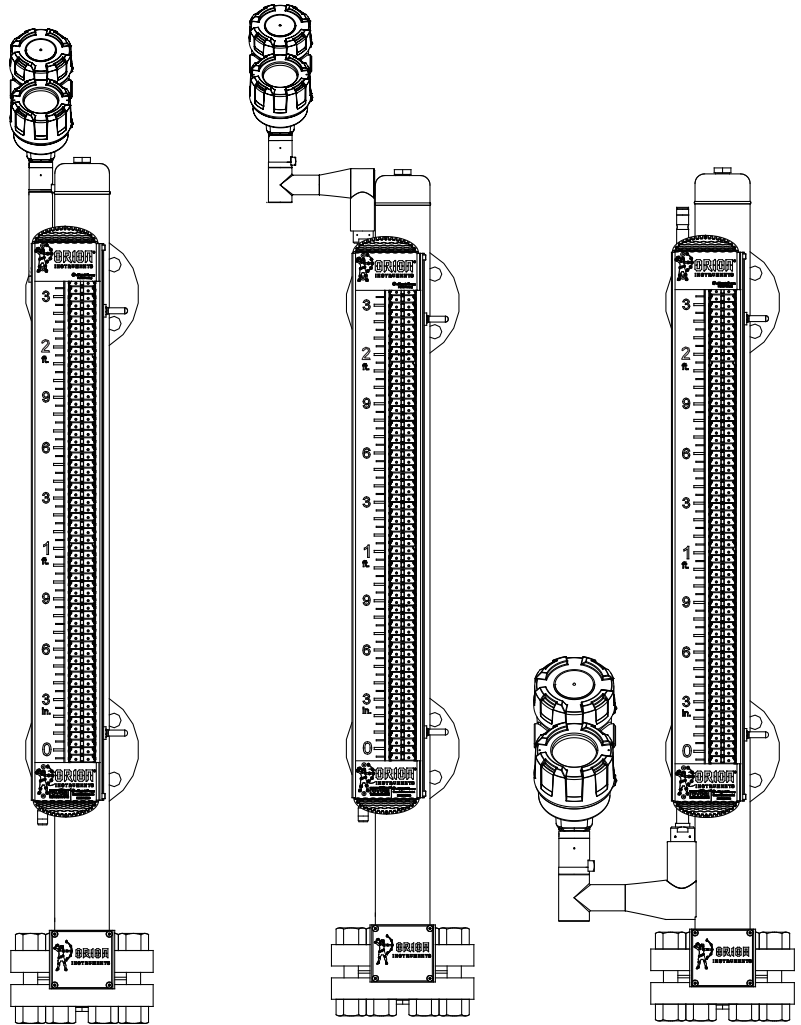

Fig. 2-4a
Top Mount

Fig. 2-4b
Top Mount Offset

Fig. 2-4c
Bottom Mount

2.2.3 Securing the Transmitter to the MLI

Each externally mounted JM4 transmitter is provided with a set of clamps (two or more, depending on probe length) for securing to the MLI chamber. If the JM4 was ordered with an Orion MLI, it will be shipped pre-mounted, but if the transmitter was ordered separately, then it can be secured using the following steps.

1. Place the Jupiter transmitter and mounting clamps in a convenient location.
2. Position the Jupiter transmitter on the side of the MLI where it will be attached. Mark the location and the exact area where the clamps will be attached to hold the Jupiter in place. The probe should extend above and below the process connections to ensure full coverage of the desired measuring span.
3. Attach the lower clamp and tighten so that it remains in place, but loose enough so that there is still room to place the guide tab from the Jupiter between the inside of the clamp and the outer diameter of the MLI chamber.

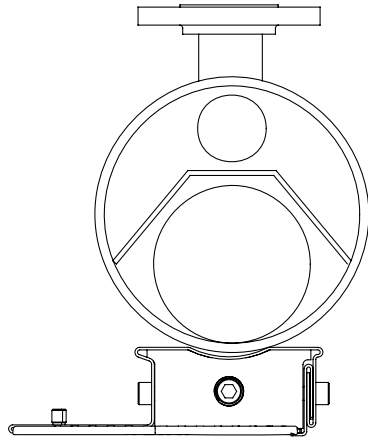

Fig. 2-5a. Aurora Cross-section

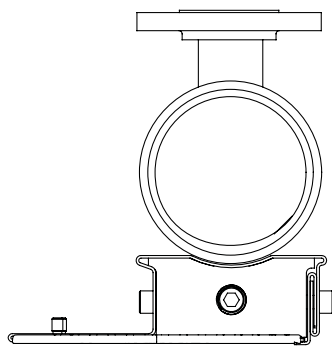

Fig. 2-5b. Atlas Cross-section

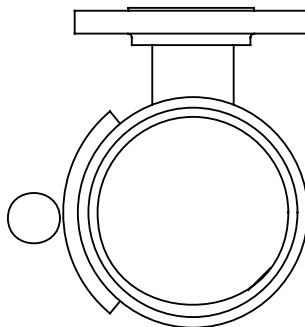

Fig. 2-6a. Insulation Pad

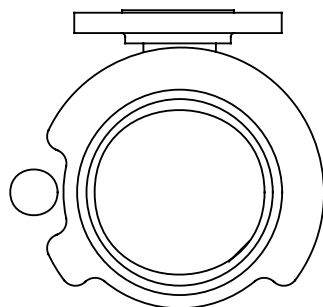

Fig. 2-6b. Insulation Blanket

4. The upper clamp will need to be open to a large enough diameter to be able to mount to the MLI as well as the probe. The upper clamp should be positioned just above the $\frac{3}{4}$ " NPT threads.
5. Mount the Jupiter guide pin in the lower clamp and tighten. If necessary, use strapping tape to temporarily hold in place on the MLI.
6. Position the upper clamp to attach the unit to the MLI and tighten.
7. Discard any tape temporarily holding the Jupiter to the MLI.

2.2.4 Installation on Atlas™ vs. Aurora®

When mounting the Jupiter model JM4 transmitter onto the outside of an MLI, float proximity must be taken into account. For an Orion Atlas MLI, the distance between the float and the chamber wall is the same all around the chamber, so the transmitter could be placed anywhere. However, for an Aurora MLI, the chamber is divided into two sections: the float section and the magnetostrictive probe/gas-bypass section (see Figure 2-5a). Because of this, the transmitter must specifically placed as close to the float section as possible, to ensure proper signal strength.

2.2.5 Insulation

For personnel and equipment protection, high-temperature insulation is available with JM4 transmitters. Insulation pads provide protection for the transmitter only, whereas insulation blankets cover the entire chamber, which can help protect personnel from elevated temperatures.

To install a JM4 with an insulation pad, first secure pad to the chamber, then secure the transmitter over the pad (see Figure 2-6a). To install a JM4 with an insulation blanket, secure the blanket over the chamber, then be sure to place the transmitter in the smaller of the two grooves, leaving the larger groove for visual indication (see Figure 2-6b).

2.2.6 Vibration Kit

For applications in which vibration is an issue, the Jupiter model JM4 is available with a vibration absorption kit.

2.3 Mounting for Direct Insertion

2.3.1 Available Configurations

The direct insertion version of the JM4 transmitter has several available configurations as well. As with external-mount, direction insertion JM4 is available with one or two floats. JM4 can be installed in external chambers or into the main vessel. It is also available with a centering disc and/or stilling well to keep the probe in position.

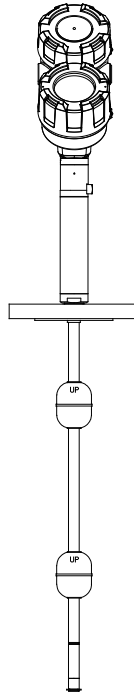

Fig. 2-7a
Direct Insertion, Two Floats

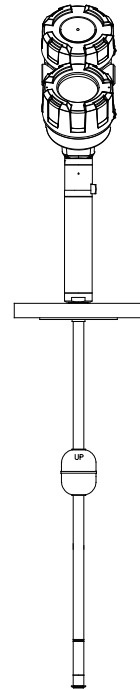

Fig. 2-7b
Direct Insertion, One Float

2.3.2 Float Installation

Use caution when handling probes to ensure probe is not bent during installation. A bend in the probe may prevent float from traveling freely up and down the probe.

1. Verify float will pass through vessel opening, if not, it will be necessary to attach the float after the probe is installed.
2. Carefully insert probe into vessel and thread or bolt to the mating connection as appropriate.
3. The float is held on the probe by a C-clip inserted into a groove machined into the tip of the probe. The float is attached or removed by removing and reinserting the C-clip. To ensure proper float orientation, the float is marked "UP".

NOTE: When placing floats on probe, make sure the side marked "UP" is facing up. If there are two floats, make sure the total level float (the lighter float) is on top, and the interface float (the heavier float) is on the bottom.

2.3.3 Centering Disc

All Jupiter model JM4 transmitters that come with a stilling well are also provided with a centering disc to prevent the probe from making contact with the stilling well.

2.4 Wiring

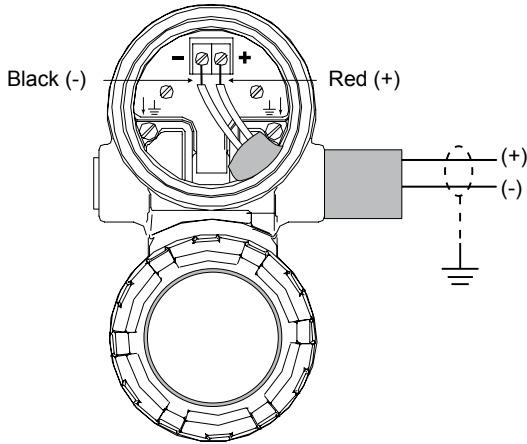

Fig. 2-8. Wiring Diagram

Caution: General purpose FOUNDATION fieldbus version of the JUPITER Model JM4 transmitter operates at 9–32 VDC (FISCO/FNICO 9–17.5 VDC). Higher voltages will damage the transmitter.

Wiring connections between the power supply and the Jupiter Model JM4 transmitter should be made using 18-22 AWG shielded twisted pair instrument cable. Connections are made to the terminal strip and the ground connections within the top enclosure compartment.

The directions for wiring the Jupiter transmitter depend on the applications:

- General Purpose or Non-Incendive (CI I, Div. 2)
- Intrinsically Safe
- Explosion Proof

For more technical details, refer to Fieldbus Foundation.

WARNING! Explosion hazard. Do not disconnect equipment unless power has been switched off or the area is known to be non-hazardous.

2.4.1 General Purpose or Non-Incendive (CI I, Div. 2)

A general purpose installation does not have flammable media present.

Areas rated Non-Incendive (CI I, Div. 2) have flammable media present only under abnormal conditions.

No special electrical connections are required.

Caution: If flammable media is contained in the vessel, the transmitter must be installed per Class I, Div 1 standards of area classification.

To install General Purpose or Non-Incendive wiring:

1. Remove the cover from the wiring compartment of the transmitter. Install the conduit plug in the unused opening and use PTFE tape/sealant to ensure a liquid-tight connection.
2. Install a conduit fitting and pull the supply wires.
3. Connect shield to an earth ground at power supply.
4. Connect an earth ground wire to the nearest green ground screw (not shown in illustration).
5. Connect the positive supply wire to the (+) terminal and the negative supply wire to the (-) terminal.

-
6. Replace and tighten the cover to the transmitter wiring compartment before applying power.

2.4.2 Intrinsically Safe (FISCO)

An Intrinsically Safe (IS) installation potentially has flammable media present. An approved IS barrier must be installed in the non-hazardous (safe) area to limit the available energy out to the hazardous area. *See Agency Approvals, Section 5.5.*

To install Intrinsically Safe wiring:

1. Ensure that the IS barrier is properly installed in the safe area (refer to local plant or facility procedures). Complete the wiring from the power supply to the barrier and from the barrier to the JM4 transmitter.
2. Remove the cover from the wiring compartment of the transmitter. Install the conduit plug in the unused opening and use PTFE tape/sealant to ensure a liquid-tight connection.
3. Install a conduit fitting and pull the supply wires.
4. Connect shield to an earth ground at power supply.
5. Connect an earth ground wire to the nearest green ground screw (not shown in illustration).
6. Connect the positive supply wire to the (+) terminal and the negative supply wire to the (-) terminal.
7. Replace and tighten the cover to the wiring compartment of the transmitter before applying power.

2.4.3 Explosion Proof

Explosion Proof (also referred to as XP or flameproof) is another method of designing equipment for installation into hazardous areas. A hazardous location is an area in which flammable gases or vapors are (or may be) present in the air in quantities sufficient to produce explosive or ignitable mixtures

The wiring for the transmitter must be contained in Explosion Proof conduit extending into the safe area.

- Due to the specialized design of the JM4 transmitter, no Explosion Proof conduit fitting (EY seal) is required within 18" of the transmitter.
- An Explosion Proof conduit fitting (EY seal) is required between the hazardous and safe areas.

To install Explosion Proof transmitter:

1. Install Explosion Proof conduit from the safe area to the conduit connection of the JM4 transmitter (refer to the local plant or facility procedures).
2. Remove the cover from the wiring compartment of the transmitter.
3. Connect shield to an earth ground at the power supply.

4. Connect an Earth ground wire to the nearest green ground screw per local electrical code (not shown in illustration).
5. Connect the positive supply wire to the (+) terminal and the negative supply wire to the (-) terminal.
6. Replace and tighten the cover to the wiring compartment of the transmitter before applying power.

2.5 Configuration

Although the Jupiter Model JM4 transmitter can be delivered pre-configured from the factory, it can also be easily reconfigured in the shop or at the installation using the local LCD/Keypad, HART communicator, or PACTware/DTM. Bench configuration provides a convenient and efficient way to set up the transmitter before going to the tank site to complete the installation.

Before configuring any transmitter, collect all operating parameters information.

Apply power to the transmitter and follow the step-by-step procedures below for the menu-driven transmitter display. See Sections 2.5.2

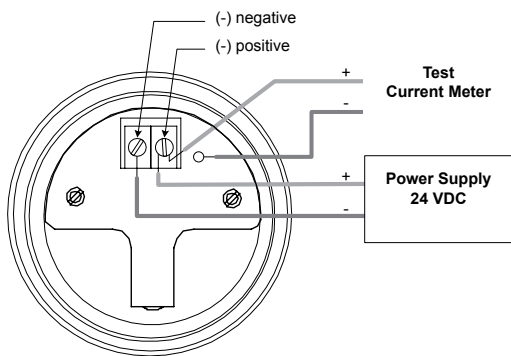

Fig. 2-9. G.P./I.S./Explosion Proof Model

2.5.1 Bench Configuration

The Jupiter Model JM4 transmitter can be easily configured at a test bench by connecting a standard 24 VDC power supply directly to the transmitter terminals as shown. An optional digital multimeter is shown in the event that mA current measurements are desired.

NOTE: Current measurements taken at these test points are an approximate value. Accurate current readings should be taken with the digital multimeter directly in series with the loop.

NOTE: When using a handheld communicator for configuration, a minimum 250-ohm line load resistance is required. Refer to your communicator manual for additional information.

NOTE: The transmitter can be configured without the probe. Please disregard the "No Probe" diagnostic indicator that will appear.

2.5.2 Menu Navigation and Data Entry

The four push buttons offer various forms of functionality for navigation and data entry.

The Model JM4 user interface is hierarchical in nature, best described as a tree structure. Each level in the tree contains one or more items. Items are either menu labels or parameter names.

- Menu labels are presented in all capital letters
- Parameters are capital words

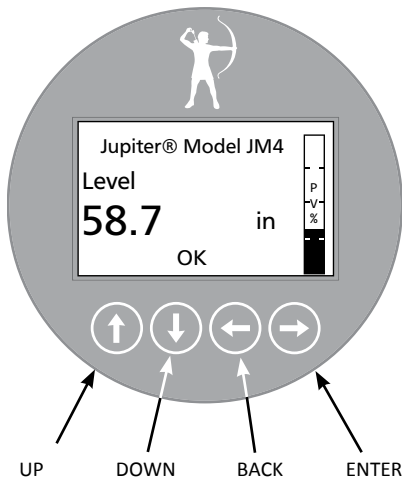

Fig 2-10. Home Screen

2.5.2.1 Navigating the Menu

- ↑ **UP** moves to the previous item in the menu branch.
- ↓ **DOWN** moves to the next item in the menu branch.
- ↶ **BACK** moves back one level to the previous (higher) branch item.
- ↵ **ENTER** enters into the lower level branch or switches to the entry mode. Holding the ENTER down on any highlighted menu name or parameter will show help text for the item.

2.5.2.2 Data Selection

This method is used for selecting configuration data from a specific list.

- ↑ **UP** and ↓ **DOWN** to navigate the menu and highlight the item of interest.
- ↵ **ENTER** allows modification of that selection.
- ↑ **UP** and ↓ **DOWN** to choose new data selection.
- ↵ **ENTER** to confirm selection.

Use ↶ **BACK** (Escape) key at any time to abort the procedure and escape to previous branch item.

2.5.2.3 Entering Numeric Data Using Digit Entry

This method is used to input numeric data, e.g., Probe Length, set 4mA and set 20mA.

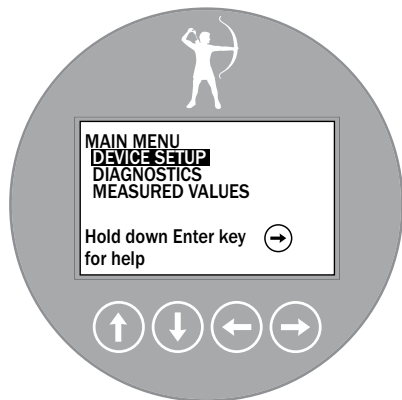

Fig. 2-11. Main Menu





Push Button		Keystroke Action
↑	Up	Moves up to the next highest digit (0,1,2,3,....,9 or decimal point). If held down the digits scroll until the push button is released.
↓	Down	Moves down to the next lowest digit (0,1,2,3,....,9 or decimal point). If held down the digits scroll until the push button is released.
↶	Back	Moves the cursor to the left and deletes a digit. If the cursor is already at the leftmost position, then the screen is exited without changing the previously saved value.
↵	Enter	Moves the cursor to the right. If the cursor is located at a blank character position, the new value is saved.

All numeric values are left-justified, and new values are entered from left to right. A decimal point can be entered after the first digit is entered, such that .9 is entered as 0.9.

Some configuration parameters can have a negative value. In this case, the leftmost position is reversed for the sign (either “-” for a negative value, or “+” for a positive value).

2.5.2.4 Entering Numeric Data Using Increment/Decrement





Use this method to input the following data into parameters such as Damping and Failure Alarm.

Push Button		Keystroke Action
	Up	Increments the displayed value. If held down the digits scroll until the push button is released. Depending on which screen is being revised, the increment amount may increase by a factor of 10 after the value has been incremented 10 times.
	Down	Decrements the displayed value. If held down the digits scroll until the push button is released. Depending on which screen is being revised, the decrement amount may increase by a factor of 10 after the value has been decremented 10 times.
	Back	Returns to the previous menu without changing the original value, which is immediately redisplayed.
	Enter	Accepts the displayed value and returns to the previous menu.

2.5.2.5 Entering Character Data

This method is used for parameters requiring alphanumeric character entry, such as for entering tags, etc.

General Menu Notes:

Push Button		Keystroke Action
	Up	Moves to the previous character (Z...Y...X...W). If held down, the characters scroll until the push button is released.
	Down	Moves to the next item character (A...B...C...D). If held down, the characters scroll until the push button is released.
	Back	Moves the cursor back to the left. If the cursor is already at the leftmost position, then the screen is exited without changing the original tag characters.
	Enter	Moves the cursor forward to the right. If the cursor is at the rightmost position, then the new tag is saved.

2.5.3 Password Protection

The Jupiter Model JM4 transmitter has three levels of password protection to restrict access to certain portions of the menu structure that affect the operation of the system. The user password can be changed to any numerical value up to 59999. When the transmitter is programmed for password protection, a password is required whenever configuration values are changed.

User Password

The User Password allows the customer to limit access to the basic configuration parameters.

The default User Password installed in the transmitter at the factory is 0. With a password of 0, the transmitter is no longer password protected, and any value in the basic user menus can be adjusted without entering a confirming password.

NOTE: If a User is not known or has been misplaced, the menu item New Password in the DEVICE SETUP/ADVANCED CONFIG menu displays an encrypted value representing the present password. Contact Technical Support with this encrypted password to retrieve the original User Password.

Advanced Password

Certain portions of the menu structure that contain more advanced parameters are further protected by an Advanced Password.

This password will be provided when necessary, by Factory technical support.

Factory Password

Calibration-related and other factory settings are further protected by a Factory Password.

2.5.4 Model JM4 Menu: Step-By-Step Procedure

The following tables provide a complete explanation of the software menus displayed by the JM4 transmitter. The menu layout is similar between the local Keypad/LCD interface, the DD, and the DTM.

Use these tables as a step-by-step guide to configure the transmitter based on the desired measurement type from the following selections:

- **Level Only**
- **Interface Only**
- **Interface & Level**
- **Level & Volume**

HOME SCREEN

The Home Screen consists of a “slide show” sequence of Measured Values screens which are rotated at 2-second intervals. Each Home Measured Value screen can present up to four information items:

- Physical Device Tag
- Measured Value Label, Numerical Value, Units
- Status will be displayed as text or optionally with NAMUR NE 107 symbol
- Primary Value Bar Graph (shown in %)

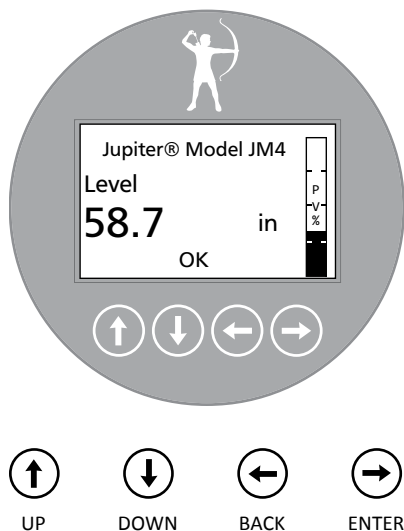

Fig 2-12
Home Screen

The Home Screen presentation can be customized by viewing or hiding some of these items.

Figure 2-12 is an example of a Home Screen for a Model JM4 configured for a Level Only application.

MAIN MENU

Pressing any key on the Home Screen will present the Main Menu, consisting of three basic menu labels shown in all capital letters.

- **DEVICE SETUP**
- **DIAGNOSTICS**
- **MEASURED VALUES**

As shown, the reverse video represents a cursor identifying the selected item, which will appear in reverse video on the LCD. The actions of the keys at this point are:



Fig. 2-13. Device Setup Menu

Push Button		Keystroke Action
	Up	No action, as the cursor is already at the first item in the MAIN MENU
	Down	Moves the cursor to DIAGNOSTICS
	Back	Moves back to HOME SCREEN, the level above MAIN MENU
	Enter	Presents the selected item, DEVICE SETUP

NOTES:

1. Items and parameters that are shown in lower level menus will depend on the Measurement Type chosen. Those parameters not applicable to the present Measurement Type will be hidden.
2. Holding down the Enter key when the cursor is highlighted over a parameter or menu will provide additional information about that item.

DEVICE SETUP

Choosing DEVICE SETUP from the MAIN MENU will result in an LCD presentation as shown at left.

The small down arrow shown at the right hand side of the screen is the indication that more items are available below and can be accessed by pressing the DOWN key.

Section 2.5.6 shows the entire tree menu for the Model JM4 DEVICE SETUP Menu.

MEASURED VALUES

Allows the user to scroll through all of the available measured values for the measurement type chosen.

2.5.5 Auto-Configuration/Reset New Probe Diagnostic ▬

Each JM4 probe has its own set of configuration parameters stored inside. With these parameters, it is possible to auto-configure the transmitter using the following steps.

1. Connect the new probe to the transmitter.
2. The home screen will display a “Device Failure New Probe” message in alternating video on the screen.
3. Pressing any key will bring the user directly to the “Clear New Probe Diagnostic” line in the Device Setup\Advanced Config\Probe Params menu.

NOTE: Clear New Probe Diagnostic will replace current settings with those needed to properly use the newly attached probe. Before executing, consider saving a file containing your current Basic Config, I/O Config, and Local Display Config settings for reference using the DTM or a handheld communicator.

4. Press the Enter key to initiate the clearing process.

2.5.6 Model JM4 Configuration Menu – Device Setup

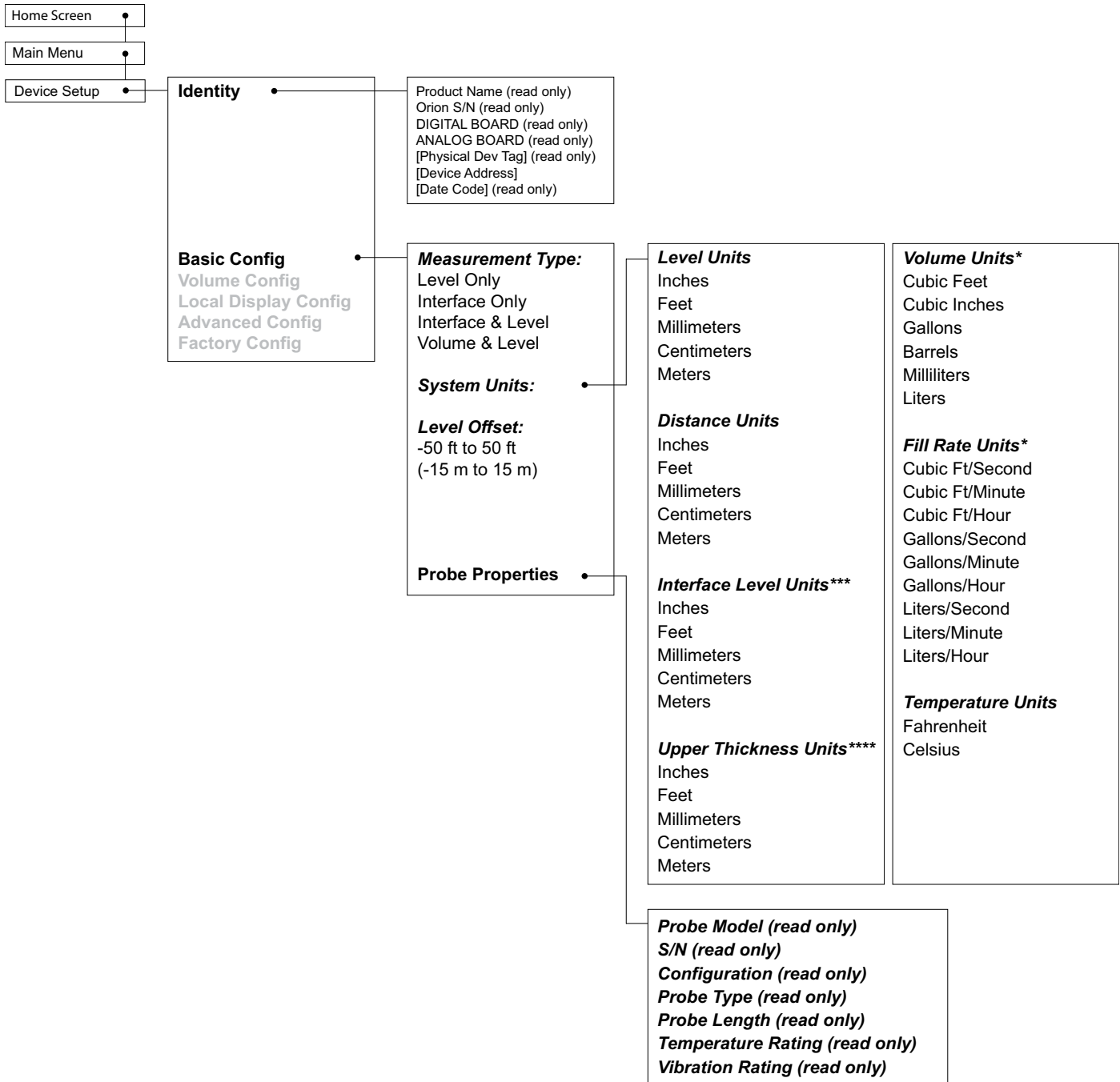

* Only available when Measurement Type = Volume & Level

** Not available when Measurement Type = Interface Only

*** Only available when Measurement Type = Interface Only or Interface & Level

**** Only Available when Measurement Type = Interface & Level

2.5.6 Model JM4 Configuration Menu – Device Setup

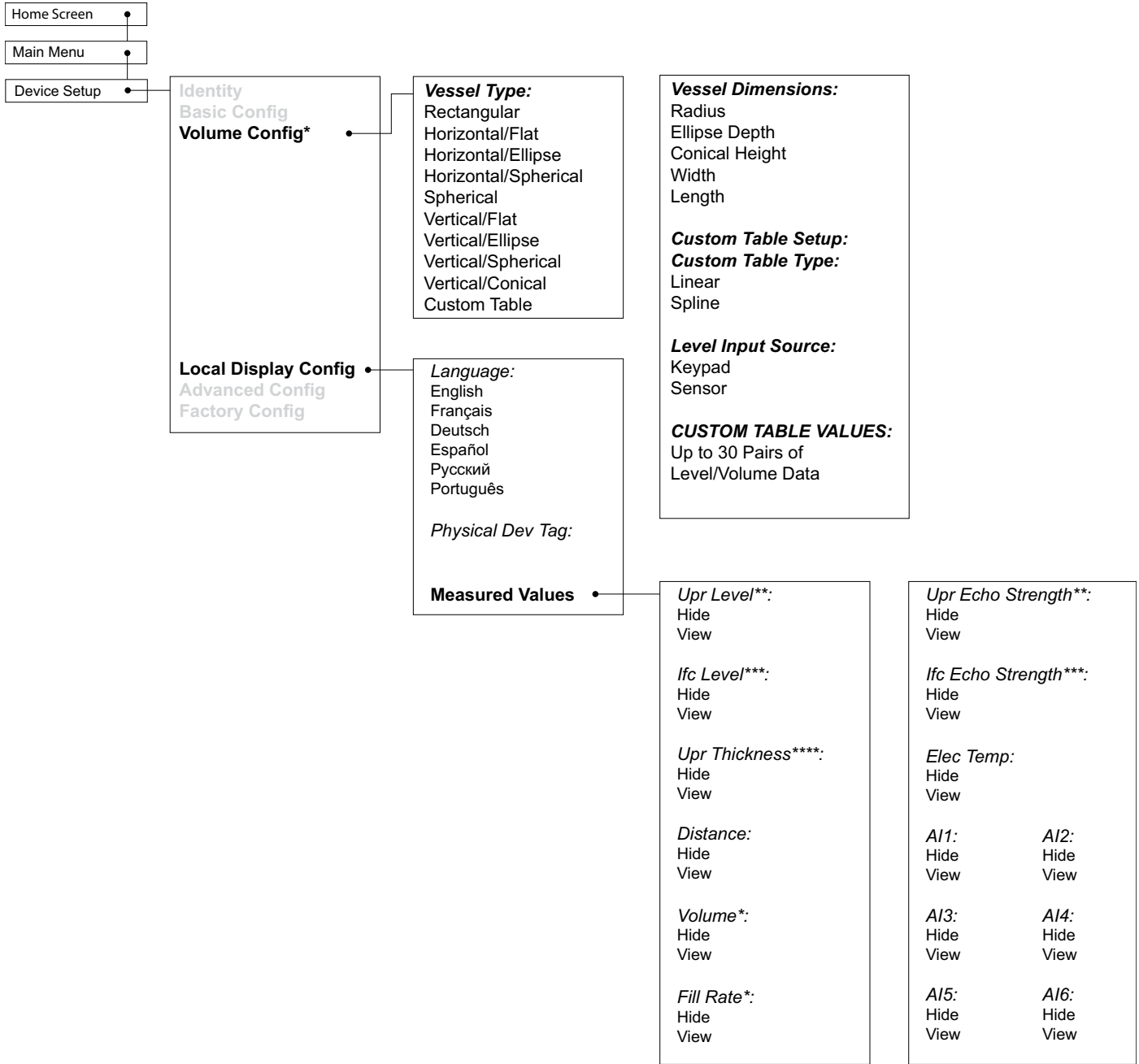

* Only available when Measurement Type = Volume & Level

** Not available when Measurement Type = Interface Only

*** Only available when Measurement Type = Interface Only or Interface & Level

**** Only Available when Measurement Type = Interface & Level

2.5.6 Model JM4 Configuration Menu – Device Setup

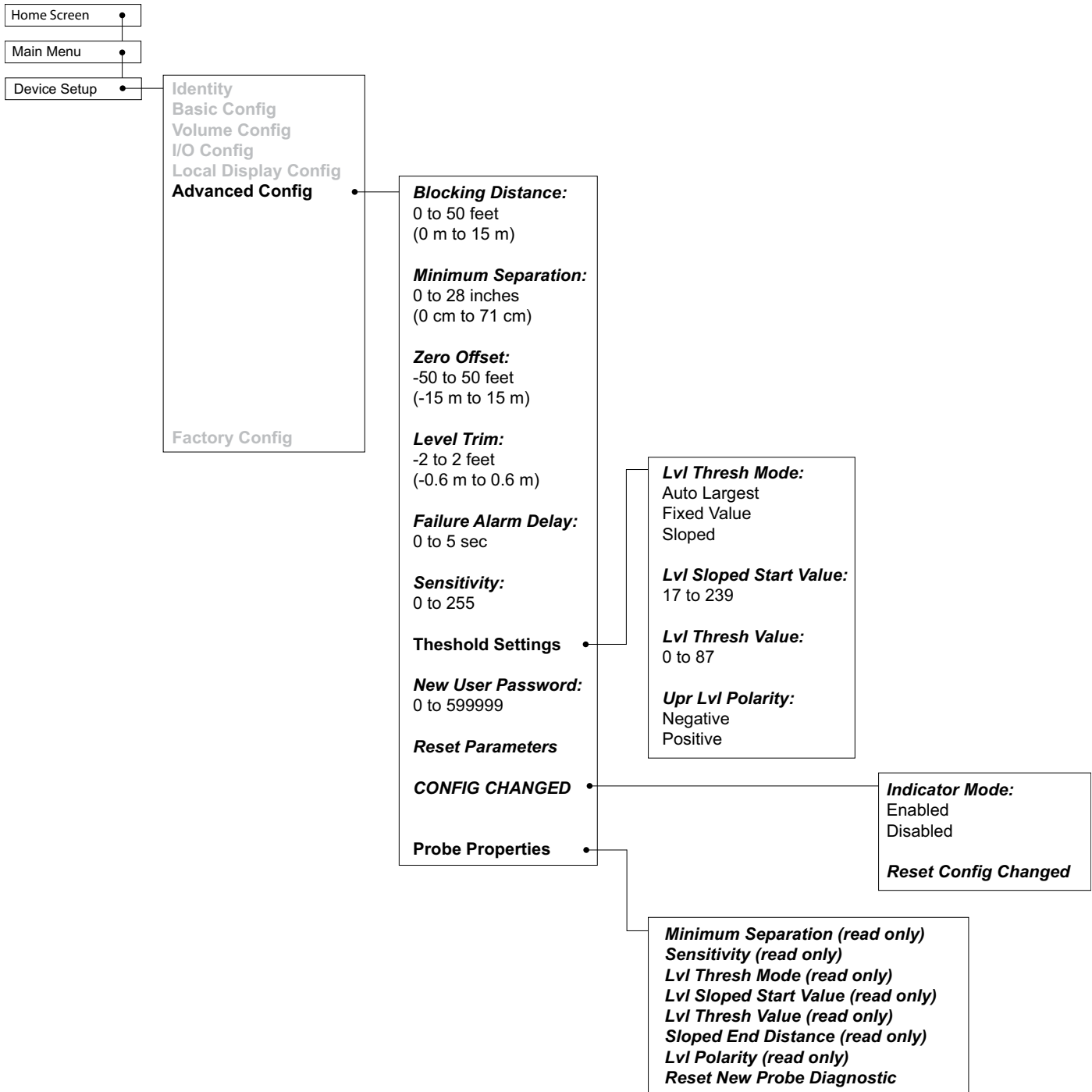

* Only available when Measurement Type = Volume & Level

** Not available when Measurement Type = Interface Only

*** Only available when Measurement Type = Interface Only or Interface & Level

**** Only Available when Measurement Type = Interface & Level

2.5.6 Model JM4 Configuration Menu – Device Setup

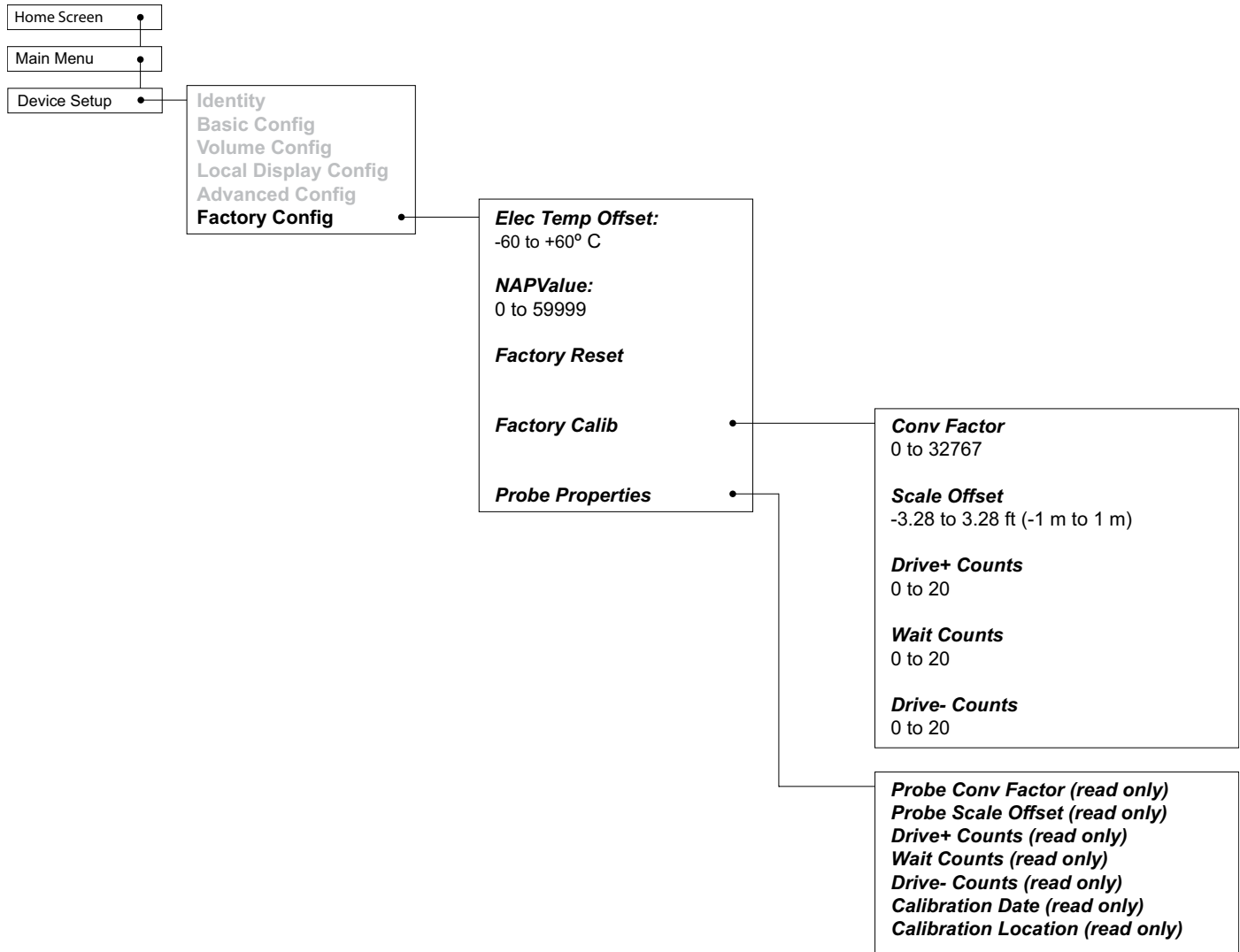

- * Only available when Measurement Type = Volume & Level
- ** Not available when Measurement Type = Interface Only
- *** Only available when Measurement Type = Interface Only or Interface & Level
- **** Only Available when Measurement Type = Interface & Level

3.0 Function Blocks

3.1 Overview

The function of a FOUNDATION fieldbus™ device is determined by the arrangement of a system of blocks defined by the Fieldbus Foundation. The types of blocks used in a typical User Application are described as either Standard or Advanced.

Function Blocks are built into the FOUNDATION fieldbus™ devices as needed to provide the desired control system behavior. The input and output parameters of function blocks can be linked over the Fieldbus and there can be numerous function blocks in a single User Application.

The Jupiter Model JM4FF is a Magnetostrictive level transmitter with the following standard FOUNDATION fieldbus™ Function Blocks:

- One (1) Resource Block (RB)
- Two (2) Custom Transducer Blocks (TB)
- Six (6) Analog Input Function Blocks (AI)
- Two (2) PID Blocks (PID)

With Advanced Function Blocks:

- One (1) Integrator Block (IT)
- One (1) Arithmetic Block (AR)
- One (1) Input Selector Block (IS)
- One (1) Signal Characterizer Block (SC)

The idea of Function Blocks, which a user can customize for a particular application, is a key concept of Fieldbus topology. Function Blocks consist of an algorithm, inputs and outputs, and a user-defined name.

The Transducer Block (TB) output is available to the network through the Analog Input (AI) blocks. Refer to Section 3.3 for additional information on the Transducer Blocks.

The AI blocks take the TB values and make them available as an analog value to other function blocks. The AI blocks have scaling conversion, filtering, and alarm functions.

Refer to Section 3.4 for additional information on the Analog Input Blocks.

The End User needs the Process Variable value as an Analog Input to their fieldbus network.

3.1.1 Universal Fieldbus Block Parameters

The following are general descriptions of the parameters common to all blocks. Additional information for a given parameter is described later in that specific block section.

ST_REV (static data revision): a read only parameter that gives the revision level of the static data associated with the block. This parameter will be incremented each time a static parameter attribute value is written and is a vehicle for tracking changes in static parameter attributes.

TAG_DESC (tag descriptor): a user assigned parameter that describes the intended application of any given block.

STRATEGY: a user assigned parameter that identifies groupings of blocks associated with a given network connection or control scheme.

ALERT_KEY: a user assigned parameter which may be used in sorting alarms or events generated by a block.

MODE_BLK: a structured parameter composed of the actual mode, the target mode, the permitted mode(s), and the normal mode of operation of a block.

- Target: The mode to “go to”
- Actual: The mode the “block is currently in”
- Permitted: Allowed modes that target may take on
- Normal: Most common mode for target

NOTES:

- 1) It may be required to change the the MODE_BLK target parameter to OOS (out of service) to change configuration parameters in that specific function block. (When in OOS, the normal algorithm is no longer executed and any outstanding alarms are cleared.)
- 2) All blocks must be in an operating mode for the device to operate. This requires the Resource Block and the Transducer Block to be in “AUTO” before the specific function block can be placed in a mode other than OOS (out of service).

BLOCK_ERR: a parameter that reflects the error status of hardware or software components associated with, and directly affecting, the correct operation of a block.

NOTE: A BLOCK_ERR of “Simulation Active” in the Resource Block does not mean simulation is active—it merely indicates that the simulation (hardware) enabling jumper is present and soft simulation disable is set to NO. (Refer to Section 3.4.5 for additional information).

3.2 Resource Block

The RESOURCE BLOCK describes the characteristics of the FOUNDATION fieldbus™ device such as the device name, manufacturer, and serial number. As it only contains data specific to the Jupiter Model JM4 FF transmitter, it has no control function.

3.2.1 Resource Block Parameters

NOTE: The Resource Block has no control function.

MODE_BLK: Must be in AUTO in order for the remaining blocks in the transmitter to operate.

NOTE: A Resource Block in “out of service” will stop all function block execution in the transmitter.

RS_STATE: Identifies the state of the RESOURCE block state machine. Under normal operating conditions, it should be “On-Line.”

DD_RESOURCE: A string identifying the tag of the resource that contains the Device Description for this device.

MANUFAC_ID: Contains Magnetrol International’s FOUNDATION fieldbus™ manufacturer’s ID number, which is 0x000156.

DEV_TYPE: The model number of the Jupiter Model JM4 FF transmitter (0x0005). It is used by the Host System and other fieldbus interface devices to locate the Device Descriptor (DD) file.

DEV_REV: Contains the firmware revision of the Jupiter Model JM4 FF transmitter and is used by the Host System and other fieldbus interface devices to correctly select the associated DD.

DD_REV: Contains the revision of the DD associated with the version of firmware in the Jupiter Model JM4 FF transmitter. It is used by the Host System and other Fieldbus interface devices to correctly select the associated DD.

RESTART: Default and Processor are the available selections. Default will reset the Model JM4 to the default factory block configuration.

NOTE: As RESTART DEFAULT will set most function block configuration parameters to their default values. Devices need to be reconfigured following activation of this function.

FEATURES: A list of the features available in the transmitter, such as Reports and Soft Write Lock.

FEATURES_SEL: Allows the user to turn Features on or off.

CYCLE_TYPE: Identifies the block execution methods that are available.

CYCLE_SEL: Allows the user to select the block execution method.

MIN_CYCLE_T: The time duration of the shortest cycle interval. It puts a lower limit on the scheduling of the resource.

NV_CYCLE_T: The minimum time interval between copies of non-volatile (NV) parameters to NV memory. NV memory is only updated if there has been a significant change in the dynamic value and the last value saved will be available for the restart procedure.

NOTE: After completing a download, allow several seconds before removing power from the Jupiter Model JM4 FF transmitter to ensure that all data has been saved.

FREE_SPACE: Shows the amount of available memory for further configuration. The value is zero percent in a pre-configured device.

FREE_TIME: The amount of the block processing time that is free to process additional blocks.

SHED_RCAS: The time duration at which to give up computer writes to function block RCas locations.

SHED_ROUT: The time duration at which to give up computer writes to function block ROut locations.

FAULT_STATE, SET_FSTATE, CLR_FSTATE: These only apply to output function blocks. (The Model JM4FF has no output function blocks).

MAX_NOTIFY: The maximum number of alert reports that the transmitter can send without getting a confirmation.

LIM_NOTIFY: the maximum numbers of unconfirmed alert notify messages allowed. No alerts are reported if set to zero.

CONFIRM_TIME: the time that the transmitter will wait for confirmation of receipt of a report before trying again. Retry will not occur if CONFIRM_TIME = 0.

WRITE_LOCK: When set to LOCKED, will prevent any external change to the static or non-volatile data base in the Function Block Application of the transmitter. Block connections and calculation results will proceed normally, but the configuration will be locked.

UPDATE_EVT (Update Event): Is an alert generated by a write to the static data in the block.

BLOCK_ALM (Block Alarm): Is used for configuration, hardware, connection, or system problems in the block. The cause of any specific alert is entered in the subcode field.

ALARM_SUM (Alarm Summary): Contains the current alert status, the unacknowledged states, the unreported states, and the disabled states of the alarms associated with the block.

ACK_OPTION (Acknowledge Option): Selects whether alarms associated with the block will be automatically acknowledged.

WRITE_PRI (Write Priority): The priority of the alarm generated by clearing the write lock.

WRITE_ALM (Write Alarm): The alert generated if the write lock parameter is cleared.

ITK_VER (ITK Version): Contains the version of the Interoperability Test Kit (ITK) used by the Fieldbus Foundation during their interoperability testing.

3.2.2 Additional Resource Block Parameters

Additional parameters are available within the resource block for use with NE-107 to aid in communicating device conditions to the user.

FD_VER: Major version of the Field Diagnostic specification to which this device conforms.

FD_FAIL_ACTIVE: For error conditions that have been selected for the FAIL alarm category, this parameter reflects those that have been detected as active.

FD_OFFSPEC_ACTIVE: For error conditions that have been selected for the OFFSPEC alarm category, this parameter reflects those that have been detected as active.

FD_MAINT_ACTIVE: For error conditions that have been selected for the MAINT alarm category, this parameter reflects those that have been detected as active.

FD_CHECK_ACTIVE: For error conditions that have been selected for the CHECK alarm category, this parameter reflects those that have been detected as active.

FD_FAIL_MAP: Maps conditions to be detected as active for the FAIL alarm category.

FD_OFFSPEC_MAP: Maps conditions to be detected as active for the OFFSPEC alarm category.

FD_MAINT_MAP: Maps conditions to be detected as active for the MAINT alarm category.

FD_CHECK_MAP: Maps conditions to be detected as active for the CHECK alarm category.

FD_FAIL_MASK: Used to suppress an alarm from being broadcast for single or multiple conditions that are active in the FAIL alarm category.

FD_OFFSPEC_MASK: Used to suppress an alarm from being broadcast for single or multiple conditions that are active in the OFFSPEC alarm category.

FD_MAINT_MASK: Used to suppress an alarm from being broadcast for single or multiple conditions that are active in the MAINT alarm category.

FD_CHECK_MASK: Used to suppress an alarm from being broadcast for single or multiple conditions that are active in the CHECK alarm category.

FD_FAIL_ALM: Used to broadcast a change in the associated active conditions, which are not masked, for the FAIL alarm category.

FD_OFFSPEC_ALM: Used to broadcast a change in the associated active conditions, which are not masked, for the OFFSPEC alarm category.

FD_MAINT_ALM: Used to broadcast a change in the associated active conditions, which are not masked, for the MAINT alarm category.

FD_CHECK_ALM: Used to broadcast a change in the associated active conditions, which are not masked, for the CHECK alarm category.

FD_FAIL_PRI: Specifies the priority of the FAIL alarm category.

FD_OFFSPEC_PRI: Specifies the priority of the OFFSPEC alarm category.

FD_MAINT_PRI: Specifies the priority of the MAINT alarm category.

FD_CHECK_ALM: Used to broadcast a change in the associated active conditions, which are not masked, for the CHECK alarm category.

FD_FAIL_PRI: Specifies the priority of the FAIL alarm category.

FD_OFFSPEC_PRI: Specifies the priority of the OFFSPEC alarm category.

FD_MAINT_PRI: Specifies the priority of the MAINT alarm category.

FD_CHECK_PRI: Specifies the priority of the CHECK alarm category.

FD_SIMULATE: Diagnostic conditions can be manually supplied when simulation is enabled.

FD_RECOMMEN_ACT: Describes what actions can be taken to address an active diagnostic condition.

FD_EXTENDED_ACTIVE_1: For error conditions that have been selected in the Extended_Map_1 parameter, this parameter reflects those that have been detected as active.

FD_EXTENDED_MAP_1: Allows the user finer control in selecting multiple conditions contributing to a single condition that may be mapped for the various alarm categories.

Manufacturer-Specific Parameters

SOFT_SIMULATION_DISABLE: If set to yes, enabling of simulation is disallowed regardless of the presence of the simulation jumper, and the “simulation” indicator will be cleared in the Block Error parameter. If set to no, simulation can only be enabled if the simulation jumper is present which also sets the “simulation” indicator in the Block Error parameter.

SERIAL_NUMBER: Read-only parameter that corresponds to “Magnetrol Serial Number” in the Transducer Block.

FIRMWARE_VERSION: Read-only parameter that corresponds to “Firmware Version” in the Transducer Block.

HARDWARE_VERSION: Read-only parameter that corresponds to “Hardware Version” in the Transducer Block.

3.3 Transducer Block

The TRANSDUCER block contained within the Jupiter Model JM4 FF transmitter is a custom block containing parameters that are pertinent to the transmitter itself.

TRANSDUCER Block 1 (used for level and interface operation) contains information such as the Configuration, Diagnostics, Calibration data, output level and Status information.

TRANSDUCER Block 2 contains volume parameters.

The read-only parameters and read-write parameters within the TB are grouped in a useful configuration.

- The read-only parameters report the block status and operation modes.
- The read-write parameters affect the operation of the function block and the transmitter itself.

NOTE: The TB will automatically be changed to “Out of Service” when the local interface (keypad) is used to change a parameter online. The TB must be manually placed back in service from the Host System to resume operation.

3.3.1 Transducer Block Parameters

The first six parameters in the TRANSDUCER Block are the universal parameters discussed in Section 3.1.1. After the universal parameters, six additional parameters are required for Transducer Blocks. The most notable of these parameters are **UPDATE_EVT** and **BLOCK_ALM**. It should be noted that these six additional parameters must exist but do not have to be implemented.

An important device-specific parameter found later in the TRANSDUCER Block list is **DEVICE_STATUS**, which displays the status of the device. If more than one message exists, then the messages are displayed in priority order.

If **DEVICE_STATUS** indicates a problem, refer to Section 5.3 Troubleshooting.

For a complete list of Transducer Block Parameters, refer to table in the Appendix.

NOTE: The user should compare the DD file and revision number of the device with the HOST system to ensure they are at the same revision level.

Please refer to the DD Revision Table Section 1.2.1.

Please refer to Appendix A for a complete list of the three Transducer Block parameter sets.

3.3.2 Password Parameters

To change a parameter at the local user interface, a value matching the user password must be entered (Default=1). If a static parameter is changed from the local user interface, the Associated Transducer Block goes Out of Service (OOS).

Refer to the Section 2.5.3 for additional information regarding passwords.

After 5 minutes with no keypad activity, the entered password expires. However, the device must be placed back in service from the Host System.

From the Host system network, the instrument always behaves as if it is in the user password mode by default. In other words, it is not necessary to enter the user password in order to write most parameters from the Host system.

3.3.3 Jupiter Model JM4 FF Configuration Parameters

One of the main advantages of the Jupiter Model JM4 FF magnetostrictive transmitter is that the device can be delivered pre-configured to the user.

On the other hand, part of the advantage of FOUNDATION fieldbus™ is to provide the ability to monitor changes and make adjustments to a transmitter. The Fieldbus™ concept allows a user to make adjustments if deemed necessary.

3.3.4 Jupiter Model JM4 FF Device-Specific Configuration Parameters

Refer to Jupiter Model JM4 I/O Manual ORI-650 for detailed information on the Model JM4 device-specific configuration parameters.

3.4 Analog Input Block

The ANALOG INPUT (AI) block takes the Jupiter Model JM4 FF input data, selected by channel number, and makes it available to other function blocks at its output.

The channel selections are:

Transducer Blocks	Process Variable	Channel Parameter Value (AI Blocks)
TB1 - Level	Level	1
	Interface Level	2
	Upper Thickness	3
	Distance	4
	Echo Strength	5
	Ifc Echo Strength	6
	Electronics Temperature	7
TB2 - Volume	Volume	8
	Fill Rate	9

3.4.1 AI Block Parameters

The following are general descriptions of the parameters common to all function blocks. Additional information for a given parameter may be described later in a section that describes the specific block.

ST_REV: a read only parameter that gives the revision level of the static data associated with the block. This parameter will be incremented each time a static parameter attribute value is written and is a vehicle for tracking changes in static parameter attributes.

TAG_DESC: a user assigned parameter that describes the intended application of any given block.

STRATEGY: a user assigned parameter that identifies groupings of blocks associated with a given network connection or control scheme.

ALERT_KEY: a user assigned parameter which may be used in sorting alarms or events generated by a block.

MODE_BLK: a structured parameter composed of the actual mode, the target mode, the permitted mode(s), and the normal mode of operation of a block.

-
- Target: The mode to “go to”
 - Actual: The mode the “block is currently in”
 - Permitted: Allowed modes that target may take on
 - Normal: Most common mode for target

PV: Either the primary analog value for use in executing the function, or a process value associated with it.

OUT: The primary analog value calculated as a result of executing the function block.

SIMULATE: Allows the transducer analog input or output to the block to be manually supplied when simulate is enabled. When simulate is disabled, the simulate value and status track the actual value and status. Please refer to Section 3.4.5 for additional information.

XD_SCALE: The high and low scale values, Engineering Units, and number of digits to the right of the decimal point used with the value obtained from the transducer for a specified channel.

OUT_SCALE: The high and low scale values, Engineering Units, and number of digits to the right of the decimal point to be used in displaying the OUT parameter.

GRANT_DENY: Options for controlling access of host computers and local control panels to operating, tuning, and alarm parameters of the block.

IO_OPTS: Option which the user may select to alter input and output block processing.

STATUS_OPTS: Options which the user may select in the block processing of status.

CHANNEL: The number of the logical hardware channel that is connected to this I/O block. (This information defines the transducer to be used going to or from the physical world).

L_TYPE: Determines if the values passed by the transducer block to the AI block may be used directly (Direct), or if the value is in different units and must be converted linearly (Indirect), using the input range defined for the transducer and the associated output range.

LOW_CUT: Limit used in square root processing.

PV_FTIME: Time constant of a single exponential filter for the PV, in seconds.

FIELD_VAL: Raw value of the field device in % of PV range, with a status reflecting the Transducer condition before signal characterization (L_TYPE) or filtering (PV_FTIME).

UPDATE_EVT: This alert is generated by any change to the static data.

BLOCK_ALM: The block alarm is used for all configuration, hardware, or system problems in the block.

ALARM_SUM: The current alert status, unacknowledged states, unreported states, and disabled states of the alarms associated with the function block.

ACK_OPTION: Selection of whether alarms associated with the function block will be automatically acknowledged.

ALARM_HYS: Amount the PV must return within the alarm limits before the alarm condition clears. Alarm hysteresis expressed as a percent of the span of the PV.

HI_HI_PRI: Priority of the high high alarm.

HI_HI_LIM: The setting for high high alarm in engineering units.

HI_PRI: Priority of the high alarm.

HI_LIM: The setting for high alarm in engineering units

LO_PRI: Priority of the low alarm.

LO_LIM: The setting for low alarm in engineering units.

LO_LO_PRI: Priority of the low low alarm.

LO_LO_LIM: The setting for low low alarm in engineering units.

HI_HI_ALM: The status for high high alarm and its associated time stamp.

HI_ALM: Status for high alarm and associated time stamp.

LO_ALM: Status for low alarm and associated time stamp.

LO_LO_ALM: The status for low low alarm and its associated time stamp.

BLOCK_ERR_DESC: Reports more specific details regarding some errors reported through BLOCK_ERR.

The MODE_BLK parameter (within both the TB and AI Blocks) must be set to AUTO to pass the PV Value through the AI to the network.

Transducer scaling, called XD_SCALE is applied to the PV from the CHANNEL to produce the FIELD_VAL in percent.

- Valid XD_SCALE engineering units depend on the Channel Type.

3.4.2 AI Block Diagnostics

The AI blocks can display a BLOCK_ERR diagnostic when:

1. The Channel is not set correctly. (Refer to Default Channel Table in Section 3.4).
2. XD_SCALE does not have suitable engineering units.
3. The SIMULATE parameter is active.
4. AI block MODE is O/S (out of service).

NOTE: This can be caused by the Resource Block being OOS or the AI Block not scheduled for execution.

5. L-TYPE not set or set to Direct with improper OUT_SCALE.

The AI block uses the STATUS_OPTS setting and the TRANSDUCER PV LIMIT value to modify the AI PV and OUT QUALITY.

A Damping Filter is a feature of the AI block. The PV_FTIME parameter is a time constant of a single exponential filter for the PV, in seconds. This parameter can be used to dampen out fluctuation in level due to excessive turbulence.

The AI block also has multiple ALARM functions that monitor the OUT parameter for out of bound conditions.

3.4.3 Local Display of Analog Input Transducer Block Output

The Jupiter Model JM4FF transmitter incorporates a useful feature that allows the Analog Input (AI) block Out values to be displayed on the local LCD.

NOTE: There are many reasons that AI block Out values can deviate from the measurement value originating in the Transducer block, and because the keypad and local display will only provide access to Transducer block parameters, there is no way to change (or view) the other fieldbus configuration items affecting the AI block output using the keypad and LCD.

In other words, these screens should only be considered as measured value indicators for configured transmitters. For example:

- The screens are not used for commissioning or diagnostic/troubleshooting purposes.
- Prior to full fieldbus configuration (transmitter assigned a permanent address, AI block(s) configured and scheduled for execution, etc.), the value displayed will not reflect the transducer measurement.

3.4.3.1 AI Out Display Screens

The Analog Input Block Out values can be conditionally displayed as part of the “rotating” home menu screens. A representative example is shown at left.

The screens will be formatted as shown with:

- Physical Device Tag (Selectable)
- Measured Value Status (Bad, Good, Uncertain)
- Bar Graph

For example, “AI1_Level” would be the most commonly used AI Out screen.

“AI2---” would be displayed when the channel value is 0 [uninitialized] for AI block 2.

Because the Model JM4 transmitter has eight (8) Analog Input blocks, any or all of which may be used in particular applications, a Transducer block parameter controls which AI block Out values will be displayed on the LCD.

Any or all (or none) of the AI block Out values can be selected for display on the LCD.

NOTE: In Fig. 3-1, status is shown as “Bad: Out of Service”. This message would be shown prior to commissioning.

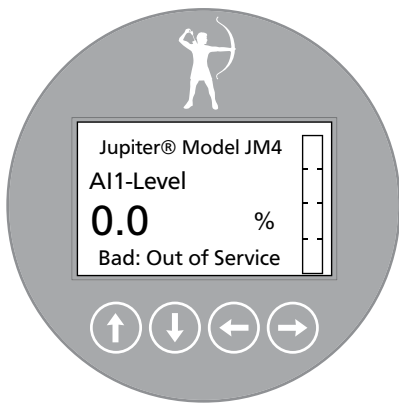
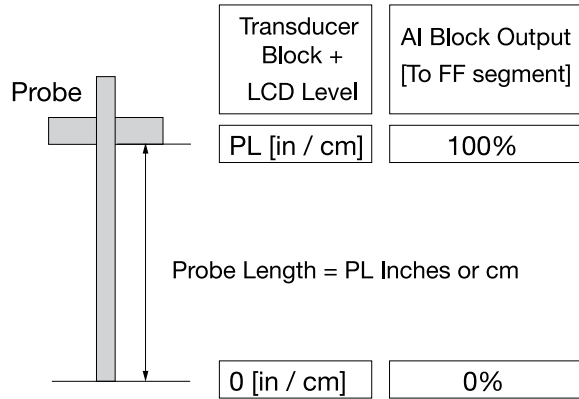

Fig. 3-1. Out of Service

3.4.4 AI Block Configuration

Below are shown some examples of various typical AI Block configurations.

Example 1: standard configuration for transmitter with probe of length PL inches or cm.
[setup by factory as part of final assembly procedure]



Configuration	
Probe Length	PL
Level Offset	0
XD Scale EU at 0%	0
XD Scale EU at 100%	PL
XD Scale Units	in/cm
Out Scale EU at 0%	0
Out Scale EU at 100%	100
Out Scale Units	%
L Type	Indirect

Example 2: end user desires 0 to 100% output for a subset of the measurable region [probe]
[e.g., for a chamber application]

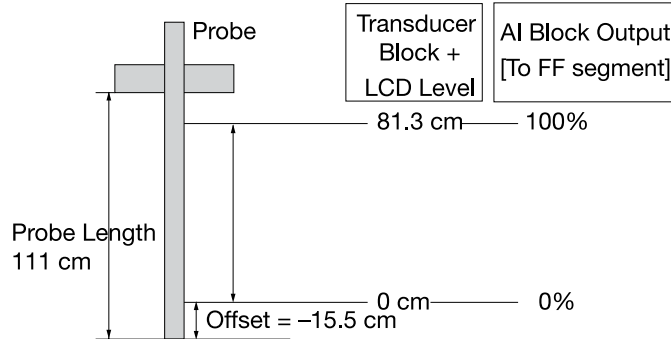

Configuration	
Probe Length	111
Level Offset	-15.5
XD Scale EU at 0%	0
XD Scale EU at 100%	81.3
XD Scale Units	cm
Out Scale EU at 0%	0
Out Scale EU at 100%	100
Out Scale Units	%
L Type	Indirect

Example 3: same configuration as previous except Direct [no] scaling setup in AI block
Output to FF segment is in cm

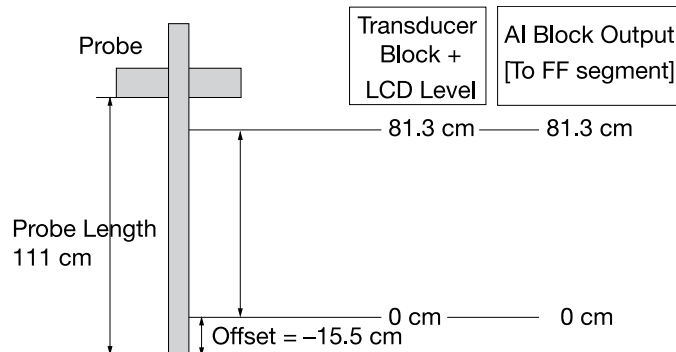

Configuration	
Probe Length	111
Level Offset	-15.5
XD Scale EU at 0%	0
XD Scale EU at 100%	81.3
XD Scale Units	cm
Out Scale EU at 0%	0
Out Scale EU at 100%	81.3
Out Scale Units	cm
L Type	Direct



Fig. 3-2. Placement of Jumper

3.4.5 Simulation Feature

The Jupiter Model JM4 with FOUNDATION fieldbus™ supports the Simulate feature in the Analog Input block. The Simulate feature is typically used to exercise the operation of an AI block by simulating a TRANSDUCER block input.

This feature cannot be activated without the placement of a hardware jumper. This jumper is installed as standard on the Jupiter Model JM4, and is placed under the display module to avoid inadvertent disabling of this feature. Refer to Figure 3-2 for jumper location.

NOTE: A BLOCK_ERR of “Simulation Active” in the Resource Block does not mean simulation is active—it merely indicates that the simulation (hardware) enabling jumper is present.

- The jumper may be removed to eliminate the BLOCK_ERR, but please note that this will permanently disable the Simulate feature.
- Refer to Section 3.2.2 for additional information on the SOFT_SIMULATION_DISABLE parameter in the resource block.

3.5 PID Block

The PID Function Block contains the logic necessary to perform Proportional/Integral/Derivative (PID) control. The block provides filtering, set point and rate limits, feed-forward support, output limits, error alarms, and mode shedding.

Although most other function blocks perform functions specific to the associated device, the PID block may reside in any device on the network. This includes a valve, a transmitter, or the host itself.

The Jupiter Model JM4 FF PID Block implementation follows the specifications documented by the Fieldbus Foundation.

3.5.1 PID Block Parameters

ACK_OPTION: Used to set auto acknowledgment of alarms.

ALARM_HYS: The amount the alarm value must return to before the associated active alarm condition clears.

ALARM_SUM: The summary alarm is used for all process alarms in the block.

ALERT_KEY: The identification number of the plant unit.

BAL_TIME: The specified time for the internal working value of bias to return to the operator set bias.

BKCAL_IN: The analog input value and status for another blocks BKCAL_OUT output.

BKCAL_HYS: The amount the output must change away from its output limit before the limit status is turned off, expressed as a percent of the span of the output.

BKCAL_OUT: The value and status required by the BKCAL_IN input for another block.

BLOCK_ALM: Used for all configuration, hardware, or system problems in the block.

BLOCK_ERR: Reflects the error status associated with the hardware or software components associated with a block.

BYPASS: Used to override the calculation of the block.

CAS_IN: The remote setpoint value from another block.

CONTROL_OPTS: Allows one to specify control strategy options.

DV_HI_ALM: The DV HI alarm data.

DV_HI_LIM: The setting for the alarm limit used to detect the deviation high alarm condition.

DV_HI_PRI: The priority of the deviation high alarm.

DV_LO_ALM: The DV LO alarm data.

DV_LO_LIM: The setting for the alarm limit used to detect the deviation low alarm condition.

DV_LO_PRI: The priority of the deviation low alarm.

FF_GAIN: The feedforward gain value.

FF_SCALE: The high and low scale values associated with FF_VAL.

FF_VAL: The feedforward control input value and status.

GAIN: The proportional gain value. This value cannot equal zero.

GRANT_DENY: Options for controlling access of host computers to alarm parameters of the block.

HI_ALM: The HI alarm data.

HI_HI_ALM: The HI HI alarm data.

HI_HI_LIM: The setting for the alarm limit used to detect the HI HI alarm condition.

HI_HI_PRI: The priority of the HI HI Alarm.

HI_LIM: The setting for the alarm limit used to detect the HI alarm condition.

HI_PRI: The priority of the HI alarm.

IN: The connection for the PV input from another block.

LO_ALM: The LO alarm data.

LO_LIM: The setting for the alarm limit used to detect the LO alarm condition.

LO_LO_ALM: The LO_LO alarm data.

LO_LO_LIM: The setting for the alarm limit used to detect the LO_LO alarm condition.

LO_LO_PRI: The priority of the LO_LO alarm.

LO_PRI: The priority of the LO alarm.

MODE_BLK: The actual, target, permitted, and normal modes of the block.

OUT: The block input value and status.

OUT_HI_LIM: The maximum output value allowed.

OUT_LO_LIM: The minimum output value allowed.

OUT_SCALE: The high and low scale values associated with OUT.

PV: The process variable use in block execution.

PV_FTIME: The time constant of the first order PV filter.

PV_SCALE: The high and low scale values associated with PV.

RATE: The derivative action time constant.

RCAS_IN: Target setpoint and status that is provided by a supervisory host.

RCAS_OUT: Block setpoint and status that is provided to a supervisory host.

RESET: The integral action time constant.

ROUT_IN: Block output that is provided by a supervisory host.

ROUT_OUT: Block output that is provided to a supervisory host.

SHED_OPT: Defines action to be taken on remote control device timeout.

SP: The target block setpoint value.

SP_HI_LIM: The highest SP value allowed.

SP_LO_LIM: The lowest SP value allowed.

SP_RATE_DN: Ramp rate for downward SP changes.

SP_RATE_UP: Ramp rate for upward SP changes.

STATUS_OPTS: Allows one to select options for status handling and processing.

STRATEGY: Can be used to identify grouping of blocks.

ST_REV: The revision level of the static data associated with the function block.

TAG_DESC: The user description of the intended application of the block.

TRK_IN_D: Discrete input that initiates external tracking.

TRK_SCALE: The high and low scale values associated with TRK_VAL.

TRK_VAL: The value applied to OUT in LO mode.

UPDATE_EVT: This alert is generated by any changes to the static data.

BLOCK-ERR-DESC: Reports more specific details regarding some errors reported through BLOCK_ERR.

4.0 Advanced Function Blocks

4.1 Integrator Block (IT)

The Integrator (IT) function block integrates one or two variables over time. The block compares the integrated or accumulated value to pre-trip and trip limits and generates discrete output signals when the limits are reached.

ST_REV: The revision level of the static data associated with the function block.

TAG_DESC: The user description of the intended application of the block.

STRATEGY: The strategy field can be used to identify grouping of blocks.

ALERT_KEY: The identification number of the plant unit. This information may be used in the host for sorting alarms.

MODE_BLK: The actual, target, permitted, and normal modes of the block.

- Target: The mode to “go to”
- Actual: The mode the “block is currently in”
- Permitted: Allowed modes that target may take on
- Normal: Most common mode for target

BLOCK_ERR: The summary of active error conditions associated with the block. The block error for the Integrator function block is Out of service.

TOTAL_SP: The set point for a batch totalization.

OUT: The block output value and status.

OUT_RANGE: The high and low scale values, engineering units code, and number of digits to the right of the decimal point associated with OUT.

GRAND_DENY: Options for controlling access of host computers and local control panels to operating, tuning, and alarm parameters of the block (not used by the device).

STATUS_OPTS: Allows you to select option for status handling and processing. The supported status option for the Integrator block is: “Uncertain if Manual mode.”

IN_1: The block input value and status.

IN_2: The block input value and status.

OUT_TRIP: The first discrete output.

OUT_PTRIP: The second discrete output.

TIME_UNIT1: Converts the rate time, units in seconds.

TIME_UNIT2: Converts the rate time, units in seconds.

UNIT_CONV: Factor to convert the engineering units of IN_2 into the engineering units of IN_1.

PULSE_VAL1: Determines the mass, volume or energy per pulse.

PULSE_VAL2: Determines the mass, volume or energy per pulse.

REV_FLOW1: Indicates reverse flow when “true”; 0- Forward, 1- Reverse

REV_FLOW2: Indicates reverse flow when “true”; 0- Forward, 1- Reverse

RESET_IN: Resets the totalizers

STOTAL: Indicates the snapshot of OUT just before a reset.

RTOTAL: Indicates the totalization of “bad” or “bad” and “uncertain” inputs, according to INTEG_OPTIONS.

SRTOTAL: The snapshot of RTOTAL just before a reset

SSP: The snapshot of TOTAL_SP

INTEG_TYPE: Defines the type of counting (up or down) and the type of resetting (demand or periodic)

INTEG_OPTIONS: A bit string to configure the type of input (rate or accumulative) used in each input, the flow direction to be considered in the totalization, the status to be considered in TOTAL and if the totalization residue should be used in the next batch (only when INTEG_TYPE=UP_AUTO or DN_AUTO).

CLOCK_PER: Establishes the period for periodic reset, in hours.

PRE_TRIP: Adjusts the amount of mass, volume or energy that should set OUT_PTRIP when the integration reaches (TOTAL_SP-PRE_TRIP) when counting up of PRE_TRIP when counting down.

N_RESET: Counts the number of resets. It cannot be written or reset.

PCT_INC: Indicates the percentage of inputs with “good” status compared to the ones with “bad” or “uncertain” and “bad” status.

GOOD_LIMIT: Sets the limit for PCT_INC. OUT. Receives the status “Good” is $PCT_INCL \geq GOOD_LIM$.

UNCERTAIN_LIMIT: Sets the limit for PCT_INC. OUT receives the status “uncertain” if PECT_INC \geq UNCERT.LIM.

OP_CMD_INT: Operator command RESET resets the totalizer

OUTAGE_LIMIT: The maximum tolerated duration for power failure

RESET_CONFIRM: Momentary discrete value with can be written by a host to enable further resets, if the option “Confirm reset” in INTEG_OPTIONS is chosen.

UPDATE_EVT: This alert is generated by any changes to the static data.

BLOCK_ALM: Used for all configuration, hardware, connection failure, or system problems in the block.

BLOCK_ERR_DESC: Reports more specific details regarding some errors reported through BLOCK_ERR.

4.2 Arithmetic Block (AR)

The Arithmetic function block provides the ability to configure a range extension function for a primary input and applies the nine (9) different arithmetic types as compensation to or augmentation of the range extended input.

The nine (9) arithmetic functions are:

- Flow Compensation Linear
- Flow Compensation Square Root
- Flow Compensation Approximate
- Btu Flow
- Traditional Multiply and Divide
- Average
- Summer
- Fourth Order Polynomial
- Simple HTG Compensate Level

ST_REV: The revision level of the static data associated with the function block. The revision value will increment each time a static parameter value in the block is changed.

TAG_DESC: The user description of the intended application of the block.

STRATEGY: The strategy field can be used to identify grouping of blocks. This data is not checked or processed by the block.

ALERT_KEY: The identification number of the plant unit. This information may be used in the host for sorting alarms, etc.

MODE_BLK: The actual, target, permitted, and normal modes of the block.

- Target: The mode to “go to”
- Actual: The mode the “block is currently in”
- Permitted: Allowed modes that target may take on
- Normal: Most common mode for target

BLOCK_ERR: This parameter reflects the error status associated with the hardware or software components associated with a block. It is a bit string so that multiple errors may be shown.

PV: The primary analog value for use in executing the function, or a process value associated with it.

OUT: The analog output value and status.

PRE_OUT: Displays what would be the OUT value if the mode was “Auto” or lower.

PV_SCALE: Associated with the PV.

OUT_RANGE: The high and low scale values, engineering units code, and number of digits to the right of the decimal point associated with OUT.

GRANT_DENY: Options for controlling access of host computers and local control panels to operating, tuning, and alarm parameters of the block.

INPUT_OPTIONS: Option bit string for handling the status of the auxiliary inputs.

IN: The block input value and status.

IN_LO: Input of the low range transmitter, in a range extension application.

IN-1, IN-2, IN-3: Inputs combined with the PV in a section of four term math functions.

RANGE_HI: Constant value above which the range extension has switch to the high range transmitter.

RANGE_LO: Constant value below which the range extension has switch to the high range transmitter.

BIAS_IN_1: The bias value for IN_1.

GAIN_IN_1: The proportional gain (multiplier) value for IN_1.

BIAS_IN_2: The bias value for IN_2.

GAIN_IN_2: The proportional gain (multiplier) value for IN_2.

BIAS_IN_3: The bias value for IN_3.

GAIN_IN_3: The proportional gain (multiplier) value for IN_3.

COMP_HI_LIM: Determines the high limit of the compensation input.

COMP_LO_LIM: Determines the low limit of the compensation input.

ARITH_TYPE: The set of 9 arithmetic functions applied as compensation to or augmentation of the range extended input.

BAL_TIME: Specifies the time for a block value to match an input, output, or calculated value or the time for dissipation of the internal balancing bias.

BIAS: The bias value is used to calculate the output.

GAIN: The gain value is used to calculate the output.

OUT_HI_LIM: The maximum output value allowed.

OUT_LO_LIM: The minimum output value allowed.

UPDATE_EVT: This alert is generated by any changes to the static data.

BLOCK_ALM: Used for all configuration, hardware, connection failure, or system problem in the block.

BLOCK_ERR_DESC: Reports more specific details regarding some errors reported through BLOCK_ERR.

4.3 Input Selector Block (IS)

The Input Selector (IS) function block can be used to select the first good, maximum, minimum, or average of as many as four input values and place it at the output. The block supports signal status propagation. (There is no process alarm detection in the Input Selector function block.)

ST_REV: The revision level of the static data associated with the function block. The revision value will be incremented each time a static parameter value in the block is changed.

TAG_DESC: The user description of the intended application of the block.

STRATEGY: The strategy field can be used to identify grouping of blocks. This data is not checked or processed by the block.

ALERT_KEY: The identification number of the plant unit. This information may be used in the host for sorting alarms, etc.

MODE_BLK : The actual, target, permitted, and normal modes of the block.

- Target: The mode to “go to”
- Actual: The mode the “block is currently in”
- Permitted: Allowed modes that target may take on
- Normal: Most common mode for target

BLOCK_ERR: This parameter reflects the error status associated with the hardware or software components associated with a block. It is a bit string, so that multiple errors may be shown.

OUT: The block output value and status.

OUT_RANGE: High and low scale values, engineering units code, and number of digits to the right of the decimal point associated with OUT

GRANT_DENY: Options for controlling access of host computers and local control panels to operating, tuning, and alarm parameters of the block.

STATUS_OPTIONS: Allows you to select options for status handling and processing. The supported status options for the input selector block are: “Use Uncertain as Good”, “Uncertain if Man mode.”

IN_1: The block input value and status.

IN_2: The block input value and status.

IN_3: The block input value and status.

IN_4: The block input value and status.

DISABLE_1: Parameter to switch off the input from being used
0- Use, 1 - Disable.

DISABLE_2: Parameter to switch off the input from being used
0- Use, 1 - Disable.

DISABLE_3: Parameter to switch off the input from being used
0- Use, 1 - Disable.

DISABLE_4: Parameter to switch off the input from being used
0- Use, 1 - Disable.

SELECT_TYPE: Determines the selector action; First good, Minimum, Maximum, Middle, Average.

MIN_GOOD: The minimum number of inputs which are “good” is less than the value of MIN_GOOD then set the OUT status to “bad”.

SELECTED: The integer indicating the selected input number.

OP_SELECT: An operator settable parameter to force a given input to be used.

UPDATE_EVT: This alert is generated by any change to the static data.

BLOCK_ALM: The block alarm is used for all configuration, hardware, connection failure, or system problems in the block.

BLOCK_ERR_DESC: Reports more specific details regarding some errors reported through BLOCK_ERR.

4.4 Signal Characterizer Block (SC)

The Signal Characterizer (SC) function block characterizes or approximates any function that defines an input/output relationship. The function is defined by configuring as many as 21 X, Y coordinates. The block interpolates an output value for a given input value using the curve defined by the configured coordinates. Two separate analog input signals can be processed simultaneously to give two corresponding separate output values using the same defined curve.

ST_REV: The revision level of the static data associated with the function block. The revision value will be incremented in each time a static parameter value in the block is changed.

TAG_DESC: The user description of the intended application of the block.

STRATEGY: The strategy field can be used to identify grouping of blocks. This data is not checked or processed by the block.

ALERT_KEY: The identification number of the plant unit. This information may be used in the host for sorting alarms, etc.

MODE_BLK: The actual, target, permitted, and normal modes of the block.

- Target: The mode to “go to”
- Actual: The mode the “block is currently in”
- Permitted: Allowed modes that target may take on
- Normal: Most common mode for target

BLOCK_ERR: This parameter reflects the error status associated with the hardware or software components associated with a block. It is a bit string so that multiple errors may be shown.

OUT1: The block output value and status.

OUT2: The block output value and status.

X_RANGE: The display scaling of the variable corresponding to the x-axis for display. It has no effect on the block.

Y_RANGE: The display scaling of the variable corresponding to the y-axis for display. It has no effect on the block.

GRANT_DENY: Options for controlling access of host computers and local control panels to operating, tuning, and alarm parameters of the block.

IN1: The block input value and status.

IN2: The block input value and status.

SWAP_2: Changes the algorithm in such a way that IN_2 corresponds to “y” and OUT_2 to “x”.

CURVE_X: Curve input points. The “x” points of the curve are defined by an array of 21 points.

CURVE_Y: Curve input points. The “y” points of the curve are defined by an array of 21 points.

UPDATE_EVT: This alert is generated by any changes to the static data.

BLOCK_ALM: The block alarm is used for all configuration, hardware, connection failure, or system problems in the block.

BLOCK_ERR_DESC: Reports more specific details regarding some errors reported through BLOCK_ERR.

5.0 Reference Information

This section presents an overview of the operation of the Jupiter magnetostrictive transmitter, information on troubleshooting common problems, listing of agency approvals, lists of replacement and recommended spare parts, and detailed functional, performance and physical specifications for the instrument.

5.1 Description

The Jupiter is a two-wire, 24 VDC level transmitter based on the concept of magnetostrictive level measurement technology.

The Jupiter electronics are housed in an ergonomic housing of two tandem compartments angled at a 45° angle for ease of wiring and configuration.

5.2 Theory of Operation

Magnetostrictive level sensors are based on “time-of-flight” technology.

Permanent magnets contained within a float device tracks the process liquid as it changes level. The Jupiter probe is fixed within close proximity to this magnetic field. A short current pulse is then applied to a specially designed wire alloy contained within the probe. The interaction of the current pulse and magnetic field causes distortion in a small section of the wire alloy. This in turn creates a vibratory disturbance which begins to travel through the wire at a very constant rate of speed. The disturbance is later detected via a sensing device at the top of the probe and sent to the electronics unit where it is filtered and amplified.

Extremely accurate level measurement can thus be obtained precisely measuring the elapsed time between the current pulse (start), and the returned pulse (stop). The Jupiter electronics module processes these signals, and then performs various mathematical operations in order to provide the user with an analog and/or digital representation of the liquid level.

5.3 Troubleshooting

The Jupiter transmitter is designed and manufactured for years of trouble free operation over a wide range of conditions. Common transmitter problems are discussed in terms of their symptoms and recommended corrective actions.

Problem	Solution
Blank display	Ensure local Keypad / LCD is properly installed. Remove power and reapply power to the unit. Check to see if LED on module is illuminated. Check voltage at terminal board. If jumper is in place under display, remove jumper.
Transmitter does not track level (External Mount)	Remove transmitter and probe from piping column and test with re-alignment magnet. Run magnet from bottom to top of probe. Check zero and span calibration. If no change in output, consult the factory.
(Direct Insertion)	Float stuck, Probe bent (Chamber)
Float inside the level gauge is moving slowly or not at all.	Ensure that the magnetic level indicator is plumb. The process fluid being measured may be too viscous and heat tracing may be required to make the material more fluid. The specific gravity of the process fluid and float weight may need to be reverified. The liquid being measured may contain magnetic particles collecting on the magnetic section of the float causing drag. If this happens magnetic trap assemblies can be purchased from the factory. Visual inspection of the float may be required to see if the float has collapsed.
LEVEL and % OUTPUT values are all inaccurate.	Wipe probe with external magnet. Confirm configuration settings.
LEVEL and % OUTPUT values fluctuate.	Turbulence, increase damping factor until readings stabilize.
Level reading on display is correct, but loop value is stuck at 4 mA.	Set poll address to zero.

5.3.1 Status Messages

Display Message	Brief Description	Solution
No Probe	No probe connected to transmitter	Check probe connection to transmitter, Consult Factory
New Probe	Probe memory contents disagree with EEPROM image	On Display, go to 'Reset New Probe' and enter password.
Analog Board Error	No response from co-processor, or clock error	Consult Factory.
Probe Memory Error	Memory device in probe is unresponsive	Consult Factory.
No Float Detected	Echo curve does not rise above threshold	Run echo curve. If a visible peak exists, increase gain/sensitivity. If there is no peak, visually inspect probe to confirm presence of float. If float still not detected, consult factory.
Config Conflict	Measurement Type and Primary Variable selection parameters are inconsistent	Confirm measurement type matches PV. Good Examples: <ol style="list-style-type: none"> 1. MT = Level Only, PV = Total Level 2. MT = Level & IFC, PV = IFC
High Volume Alarm	Level exceeds highest level in strapping table or top of vessel by more than 5%	Confirm span set points are at desired values.
Extra Float Detected	Echo curve rises above threshold additional instance from expected number	Check Measurement type; Decrease Gain/Sensitivity Settings; Swipe probe with pocket magnet to eliminate possibility of residual magnetism; Consult Factory.
2nd Float Missing	Echo curve rises above threshold only once	Check Measurement type; Increase Gain/Sensitivity Settings; Verify two floats are present. Consult Factory.
High Elec Temp	Present electronics temperature above maximum	Take measures to cool transmitter head. Consider installing sunshade.
Low Elec Temp	Present electronics temperature below minimum	Take measure to warm transmitter head. Consider installing heat tracing.
Low Supply Voltage	Power supply voltage inadequate to prevent brownout or reset	Check supply voltage.
Weak Upr Echo	Strength of echo from float at gas-liquid interface less than allowable minimum	Increase Gain/Sensitivity Settings; Consult Factory.
Weak lfc Echo	Strength of echo from float at liquid-liquid interface less than allowable minimum	Increase Gain/Sensitivity Settings; Consult Factory.
High Noise/Lvl Threshold	Strength of baseline noise too near upper level threshold	Echo Rejection may be required, Consult Factory, Swipe probe with pocket magnet to eliminate possibility of residual magnetism
High Noise/lfc Threshold	Strength of baseline noise too near interface level threshold	Echo Rejection may be required, Consult Factory, Swipe probe with pocket magnet to eliminate possibility of residual magnetism

5.4 Configuration Information

5.4.1 Volumetric Capability

Selecting Measurement Type = Volume and Level allows the Model JM4 transmitter to measure volume as the Primary Measured Value.

5.4.1.1 Configuration Using Built-In Vessel Types

The following table provides an explanation of each of the System Configuration parameters required for volume applications that use one of the nine Vessel Types.

Configuration Parameter	Explanation
Volume Units	A selection of Gallons (factory default Volume Unit), Milliliters, Liters, Cubic Feet, or Cubic Inches, is provided.
Vessel Type	Select either Vertical/Flat (factory default Vessel Type), Vertical/Elliptical, Vertical/Spherical, Vertical/Conical, Custom Table, Rectangular, Horizontal/Flat, Horizontal/Elliptical, Horizontal/Spherical, or Spherical. Note: Vessel Dims is the next screen only if a specific Vessel Type was selected. If Custom Table was selected. Refer to page 53 to select the Cust Table Type and Cust Table Vals.
Vessel Dims	See the vessel drawings on the following page for relevant measuring areas.
Radius	Used for all Vessel Types with the exception of Rectangular.
Ellipse Depth	Used for Horizontal and Vertical/Elliptical vessels.
Conical Height	Used for Vertical/Conical vessels.
Width	Used for Rectangular vessels.
Length	Used for Rectangular and Horizontal vessels.

Vessel Types

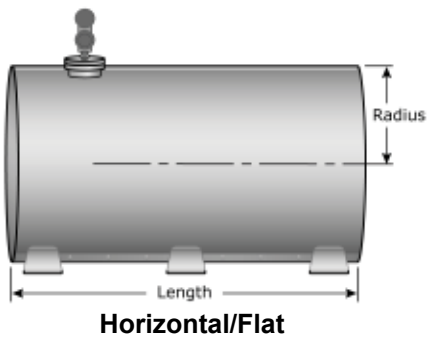
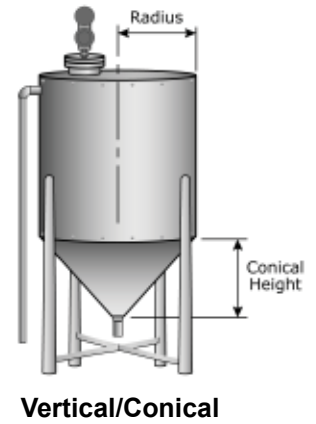
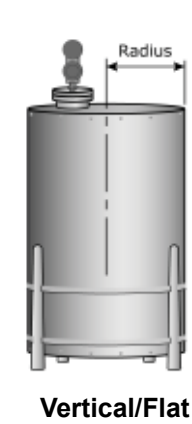
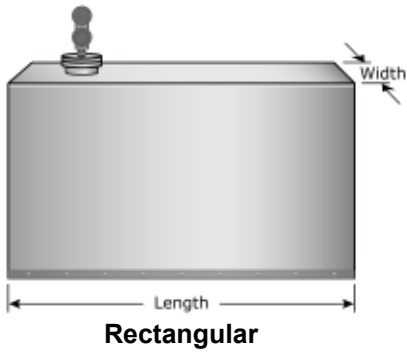
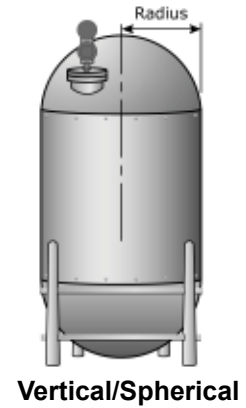
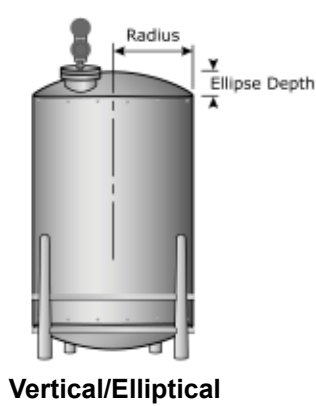
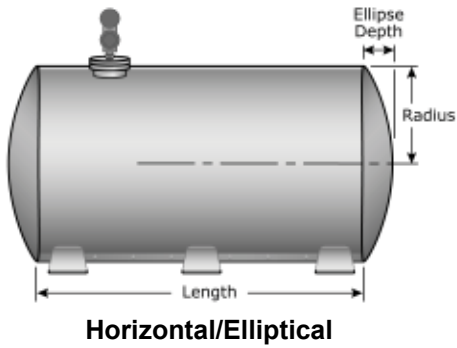
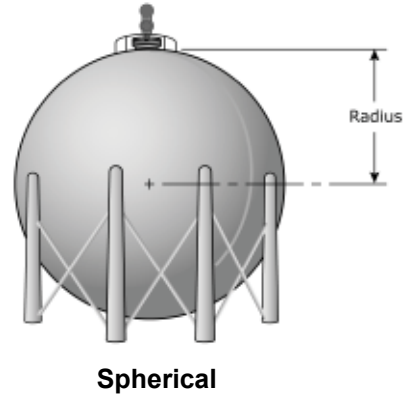
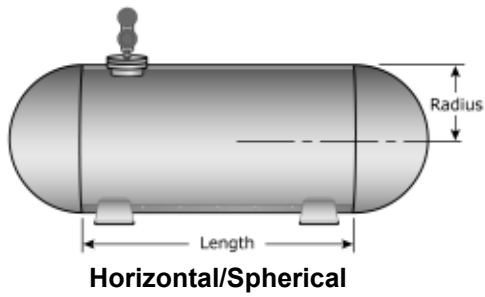

5.4.1.2 Configuration Using Custom Table

If none of the nine *Vessel Types* shown can be used, a *Custom Table* can be created. A maximum of 30 points can be used to establish the level to volume relationship. The following table provides an explanation of each of the System Configuration parameters for volume applications where a Custom Table is needed.

Configuration Parameter	Explanation (Custom Volumetric Table)
Volume Units	A selection of Gallons (factory default Volume Unit), Milliliters , Liters , Cubic Feet , or Cubic Inches , is provided.
Vessel Type	Select Custom Table if none of the nine <i>Vessel Types</i> can be used.
Cust Table Type	The <i>Custom Table</i> points can be a Linear (straight line between adjacent points) or Spline (can be a curved line between points) relationship. See below drawing for more information.
Cust Table Vals	A maximum of 30 points can be used in building the <i>Custom Table</i> . Each pair of values will have a level (height) in the units chosen in the <i>Level Units</i> screen, and the associated volume for that level point. The values must be monotonic, i.e. each pair of values must be greater than the previous level/volume pair. The last pair of values should have the highest level value and volume value associated with the level in the vessel.

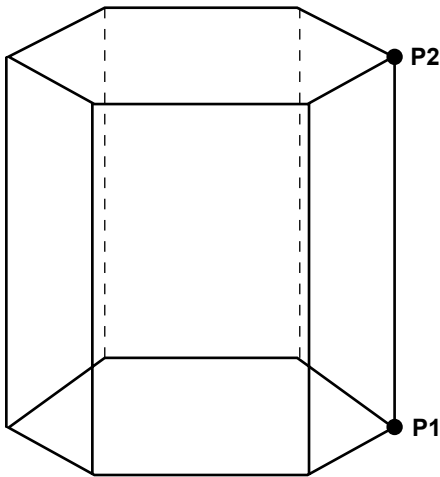

Linear

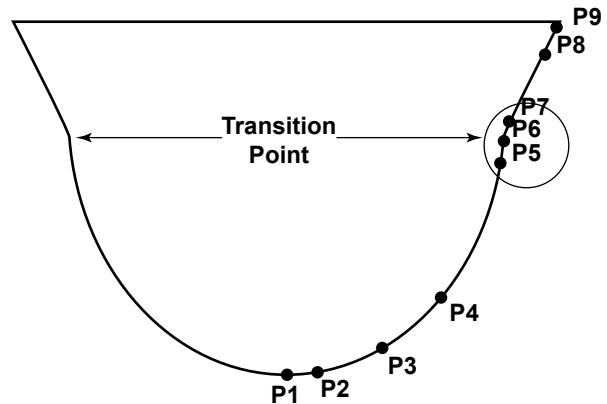

Use where walls are not perpendicular to base.

Concentrate at least two points at the beginning (P1) and end (P9); and three points at either side of transition points

SPLINE

5.4.2 Reset Function

A parameter labeled “Reset Parameter” is located at the end of the DEVICE SETUP/ADVANCED CONFIG menu. In the event a user gets confused during configuration or advanced troubleshooting, this parameter gives the user the ability to reset the Model JM4 transmitter configuration.

Unique to the Model JM4 transmitter is the ability for Orion Instruments to fully “pre-configure” devices to customer requests. For that reason, the Reset function will return the device back to the state at which it left the factory.

It is recommended that Orion Instruments Technical Support be contacted as the Advanced User password will be required for this reset.

5.4.3 Additional Diagnostic/Troubleshooting Capabilities

5.4.3.1 Event History

As a means for improved troubleshooting capability, a record of significant diagnostic events is stored with time and date stamps. A real time on board clock (which must be set by the operator), will maintain the current time.

5.4.3.2 Context-sensitive Help

Descriptive information relevant to the highlighted parameter in the menu will be accessible via the local display and remote host interfaces. This will most often be a parameter-related screen, but could also be information about menus, actions (for example, Loop [Analog Output] Test, resets of various types), diagnostic indicators, etc.

For example: Dielectric Range — Selects the range bounding the dielectric constant of the medium in vessel. For interface measurement mode, it selects the range bounding the dielectric constant of the lower liquid medium. Some ranges may not be selectable depending on the probe model.

5.4.3.3 Trend Data

Another new feature to the Model JM4 is the ability to log several measured values (selectable from any of the primary, secondary, or supplemental measured values) at a configurable rate (for example, once every five minutes) for a period ranging from several hours to a number of days (depending on the configured sample rate and number of values to be recorded). The data will be stored in nonvolatile memory in the transmitter with date and time information for subsequent retrieval and visualization using the associated Model JM4 DTM.

5.5 Agency Approvals



These units are in compliance with the EMC directive 2004/108/EC, the PED directive 97/23/EC and the ATEX directive 2014/34/EU.

<p><u>Explosion Proof</u> US/Canada: FM16US0357X/FM16CA0168X Class I, Div 1, Group B, C and D, T4 Ta = -40°C to +70°C Type 4X, IP66, IP67</p> <p><u>Flame Proof:</u> Flameproof US/ Canada: Class I, Zone 0/1, AEx db IIB + H2 T1...T6 Ga/Gb (US) Class I, Zone 0/1, Ex db IIB + H2 T1...T6 Ga/GB (Canada) Ta = - 40 C to +70 C IP66, IP67</p> <p>ATEX FM14ATEX0059X / FM22UKEX0051X: II 1/2G Ex db IIB+H2 T6... T1 Ga/Gb Ta=-40°C to +70°C IP66, IP67</p> <p>IEC- IEC Ex FMG14.0028X Ex db IIB+H2 T6...T1 Ga/Gb Ta=-40°C to +70°C IP66, IP67</p>	<p><u>Non- Incendive</u> US/Canada: FM16US0357X/FM16CA0168X U.S. - Class I, II, III, Division 2, Group A, B, C, D, E, F, G, T4, Ta = -40°C to 70°C CANADA – Class I, Division 2, Group A,B,C,D T4, Ta = -40°C to 70°C Class I, Zone 2 AEx ec IIC T4 Gc Ta = -15°C to 70°C Class I, Zone 2 Ex ec IIC T4 Gc Ta = -15°C to +70°C Class I, Zone 2 AEx ic IIC T4 Gc Class I, Zone 2 Ex ic IIC T4 Gc Ta = -40°C to +70°C Type 4X, IP66, IP67</p> <p>ATEX FM14ATEX0060X: II 3 G Ex ec IIC T4 Gc Ta = -15°C to +70°C II 3 G Ex ic IIC T4 Gc Ta = -40°C to +70°C IP66, IP67</p> <p>IEC – IECEx FMG 14.00028X: Ex ec IIC T4 Gc Ta = -15°C to +70°C Ex ic IIC T4 Gc Ta = -40°C to +70°C IP66, IP67</p>
<p><u>Intrinsically Safe</u> US/Canada: FM16US0357X/FM16CA0168X Class I, II, III, Div 1, Group A, B, C, D, E, F, G, T4, Class I, Zone 0 AEx ia IIC T4 Ga Class I, Zone 0 Ex ia IIC T4 Ga Ta =-40°C to + 70°C Type 4X, IP66, IP67</p> <p>ATEX – FM14ATEX0059X / FM22UKEX0051X: II 1 G Ex ia IIC T4 Ga Ta = -40°C to +70°C IP66, IP67</p> <p>IEC – IECEx FMG 14.0028X: Ex ia IIC T4 Ga Ta = -40°C to +70°C IP66, IP67</p>	<p><u>Dust Ignition Proof</u> US/Canada: FM16US0357X/FM16CA0168X Class II, III, Division 1, Group E, F and G, T4 Ta = 5°C to +70°C Type 4X, IP66, IP67 US/Canada Zone Ratings as follows: Zone 21, AEx tb IIIC T86C...T120C Ta= -15 C to +70 C Db (US) Zone 21, Ex tb IIIC T85C...T120C Ta = -15 C to +70 C Db (Canada) Type 4X, IP66, IP67</p> <p>ATEX – FM14ATEX0059X / FM22UKEX0051X: II 2 D Ex tb IIIC T85°C ... T120°C Db Ta = -15°C to +70°C IP66, IP67</p> <p>IEC – IECEx FMG 14.0028X: Ex tb IIIC T85°C ... T120°C Ta = -15°C to +70°C IP66, IP67</p>

SPECIAL CONDITIONS OF USE:

1. The enclosure contains aluminum and is considered to present a potential risk of ignition by impact or friction. Care must be taken during installation and use to prevent impact or friction.
2. To maintain the T4 temperature code care shall be taken to ensure the enclosure temperature does not exceed +156 °F (+70 °C).
3. The risk of electrostatic discharge shall be minimized at installation, following the direction given in the instruction.
4. For Installation with ambient temperature of +156 °F (+70 °C), refer to the manufacturer's instructions for guidance on proper selection of conductors.
5. Provisions shall be made to provide transient overvoltage protection to a level not to exceed 119 VDC.
6. WARNING – Explosion Hazard do not disconnect equipment when flammable or combustible atmosphere is present
7. When equipment is used in explosive dust atmospheres, the end user shall take precautions so that the thermal effects of the process temperature shall limit the equipment enclosure and probe surface temperatures to not exceed the required installation location temperature and shall be between +185 °F (+85 °C) and +248 °F (+120 °C).

NOTES:

1. For Explosion proof installations the I.S. ground terminal shall be connected to appropriate intrinsically safe ground in accordance with the Canadian Electrical code (CEC) or the national electrical code (NEC). For intrinsically safe installations the I.S. ground terminal does not require grounding.
2. Manufacturer's installation instructions supplied with the protective barrier and the CEC or the NEC must be followed when installing this equipment. Barrier must be certified for Canadian & U.S. installation.
3. Control equipment connected to protective barriers must not use or generate more than 250 VDC or VRMS.
4. Agency approved dust tight seals must be used when transmitter is installed in Class II & III environments.
5. For supply connections, use wire suitable for the operating temperature.
6. Agency approved barriers with linear output characteristics must be used.

5.5.1 Agency Specifications – FM Intrinsically Safe FOUNDATION fieldbus™ Installation

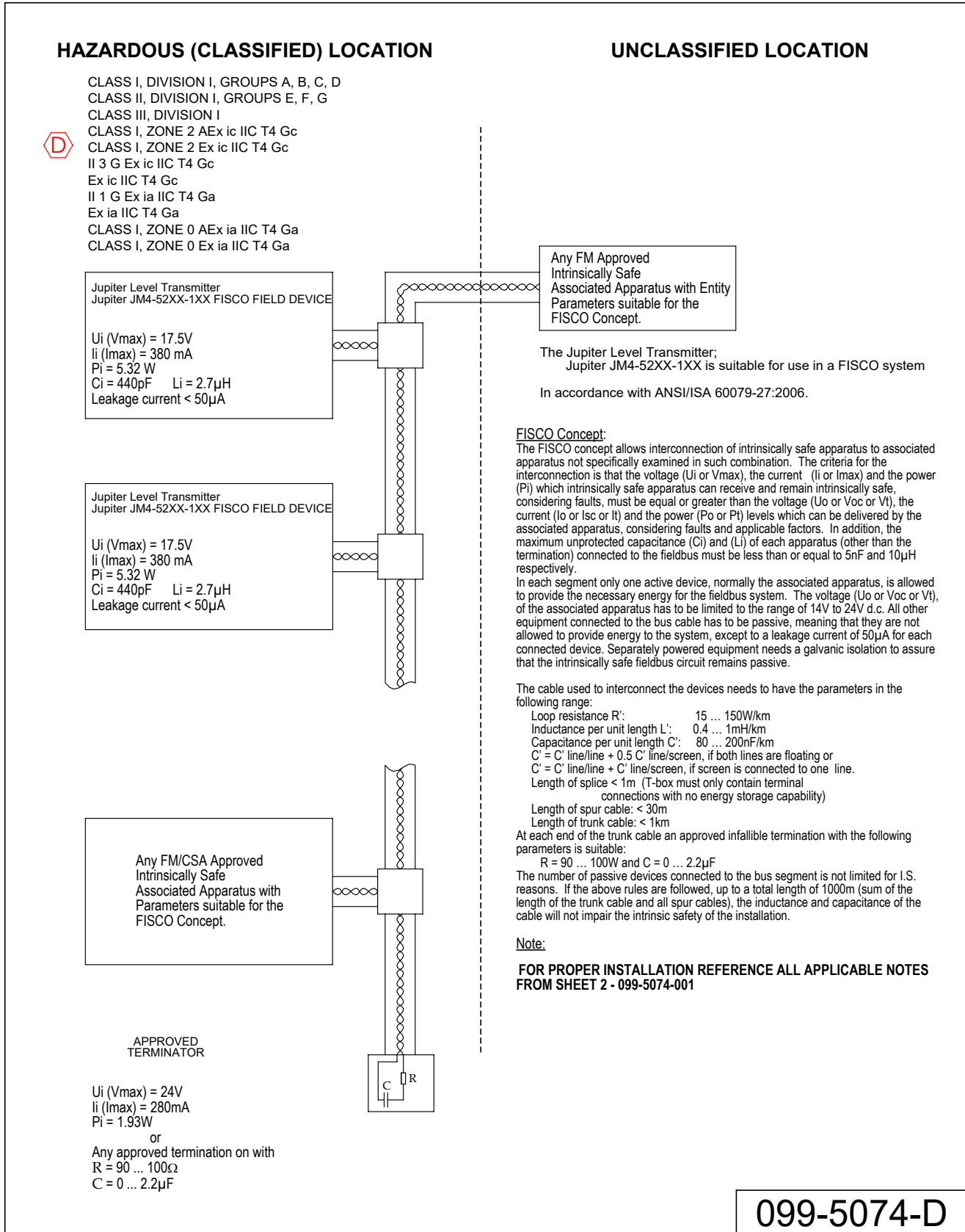

099-5074-D

5.6 Replacement Parts

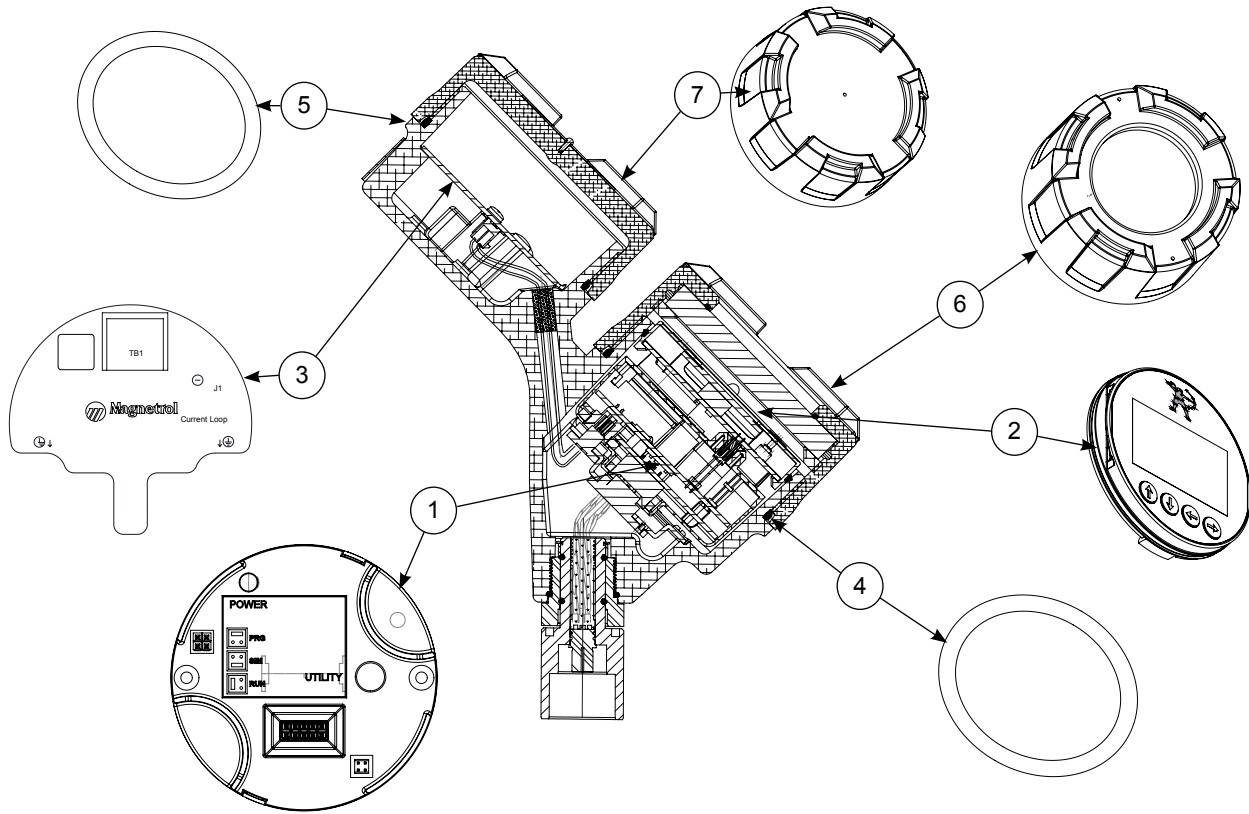

Part Number:

J	M	4
---	---	---

 —

5				
---	--	--	--	--

 —

--	--	--

(1) Electronic Module	
Digit 5	Replacement Part
1	031-2856-001
2	031-2856-002

(2) Display Module		
Digit 5	Digit 7	Replacement Part
1,2	0,1,2	-----
	A,B,C	031-2850-001

(3) Wiring PC Board	
Digit 5	Replacement Part
1	030-9165-001
2	030-9166-002

	Replacement Part
(4) "O" -ring	012-2201-237
(5) "O" -ring	012-2201-237

(6) Housing Cover			
Digits			Replacement Part
7	8	9	
0,1,2	0,1,3, A,B,C,D	1	004-9225-002
		2	004-9225-003
A,B,C	0,1,A	1	036-4413-005
	3	1	036-4413-001
A,B,C	0,1,3,A	2	036-4413-002
		1	036-4413-008
A,B,C	B,C,D	2	036-4413-009

(7) Housing Cover	
Digit 9	Replacement Part
1	004-9225-002
2	004-9225-003

5.7 Specifications (continued)

FOUNDATION fieldbus™

ITK Version	6.1.1
H1 Device Class	Link Master (LAS)—selectable ON/OFF
H1 Profile Class	31PS, 32L
Function Blocks	(6) AI, (2) Transducer, (1) Resource, (1) Arithmetic, (1) Input Selector, (1) Signal Characterizer, (2) PID, (1) Integrator
Quiescent Current	15 mA
Execution Time	15 msec (30 msec PID, Signal Characterizer Block)

Environment

Ambient Temperature Range	Transmitter:	-40°F to +158°F (-40°C to +70°C)
	Display:	-5°F to +158°F (-20°C to +70°C)
Storage Temperature		-50°F to +185°F (-46°C to +85°C)
Process Pressure (Direct Insertion)		Vacuum to 3000 psig (207bar)
Humidity		0 to 99%, non-condensing
Electromagnetic Compatibility		Meets CE requirement (EN 61326) and NAMUR NE 21
Surge Protection		Meets CE EN 61326 (1000V)
Shock/Vibration		ANSI/ISA-S71.03 Class SA1 (Shock); ANSI/ISA-S71.03 Class VC2 (Vibration)

Process Conditions

Process Temperature	External Mount:	-320°F to +850°F (-196°C to +450°C)
	Direct Insertion:	-320°F to +800°F (-196°C to +425°C)
Process Pressure	Direct Insertion:	Vacuum to 3000 psig (207 bar)

5.7.2 Physical Specifications - Transmitter

inches [mm]

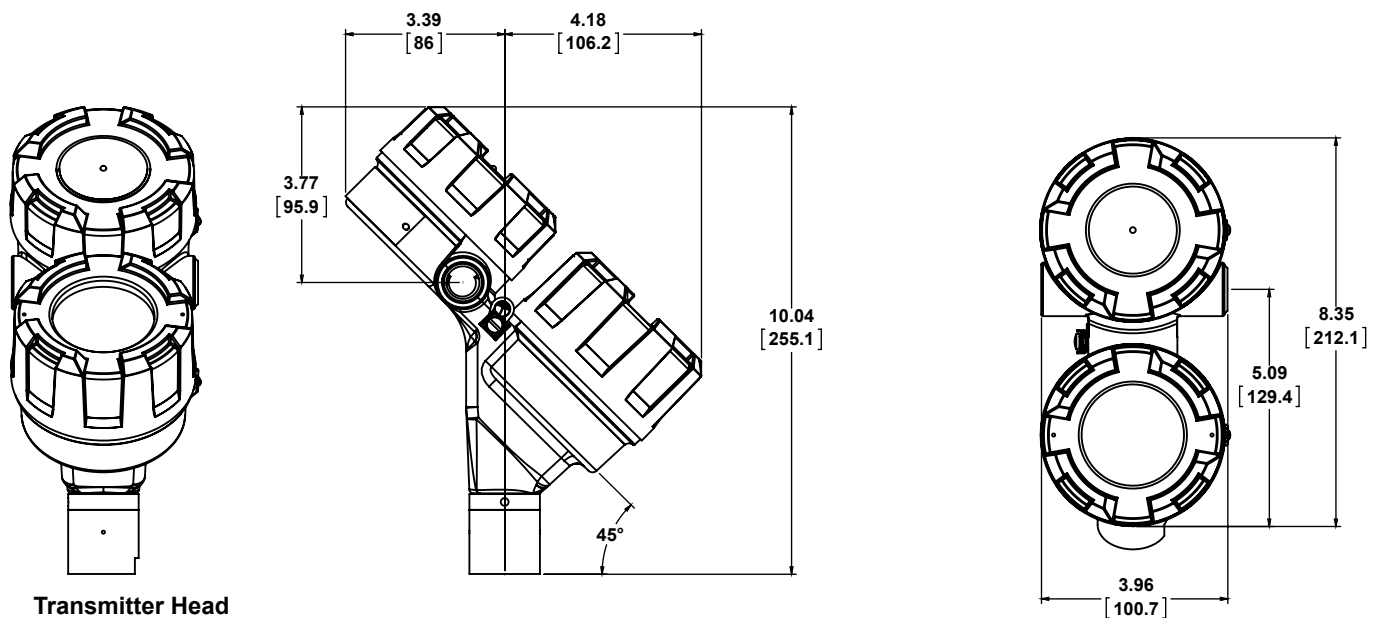

5.7.2 Physical Specifications - Transmitter (continued)

inches [mm]

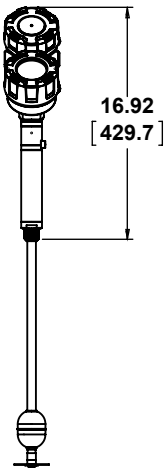

Direct Insertion
.75 NPT

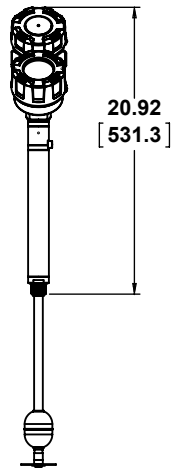

Direct Insertion
.75 NPT, High Temp & Cryo

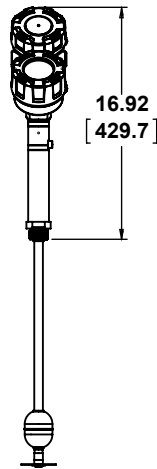

Direct Insertion
1" BSP

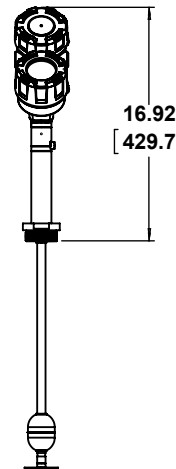

Direct Insertion
2" BSP

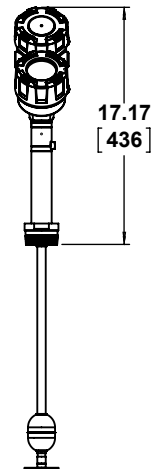

Direct Insertion
2" NPT

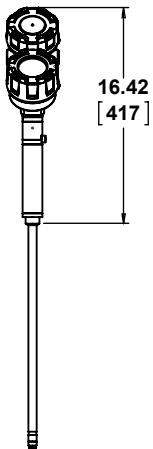

External Top Mount

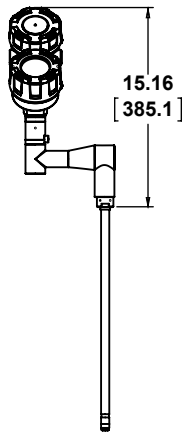

External Top Mount
Offset

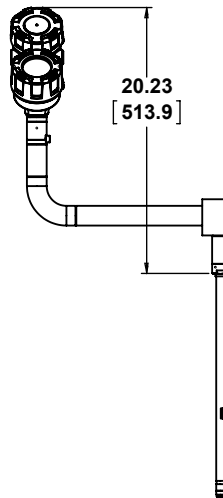

External Top Mount
Offset, Cryo

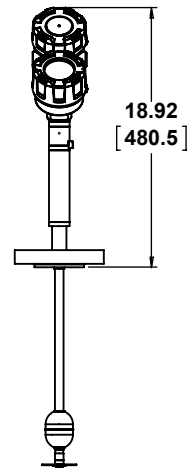

Direct Insertion
Flange

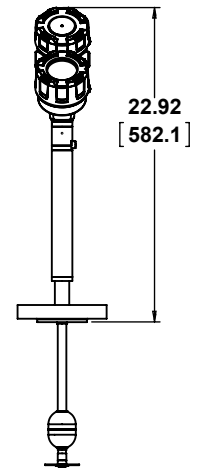

Direct Insertion
Flang, High Temp & Cryo

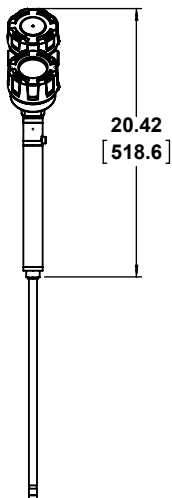

External Top Mount
High Temp & Cryo

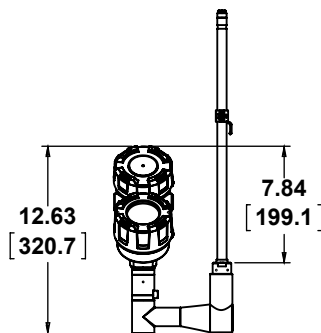

External Bottom Mount
Offset

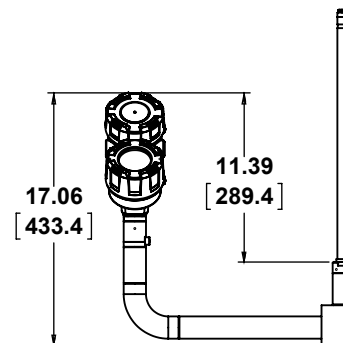

External Bottom Mount
Offset, Cryo

5.7.3 Power Supply Requirements

Safe Operating Area

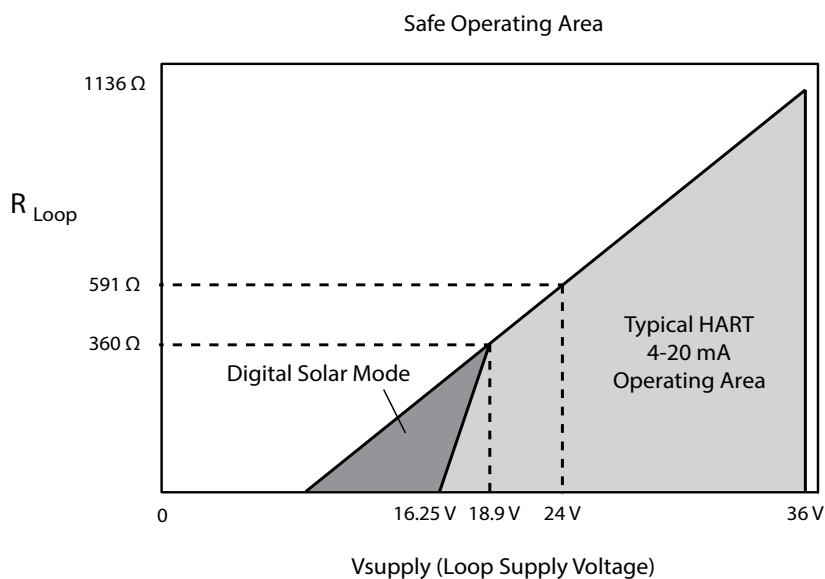

Supply Voltage

Operational Mode	Current Consumption	Vmin	Vmax
HART			
General Purpose	4mA 20mA	16.25V 11V	36V 36V
Intrinsically Safe	4mA 20mA	16.25V 11V	28.6V 28.6V
Explosion Proof	4mA 20mA	16.25V 11V	36V 36V
Fixed Current-Solar Power Operation (PV transmitter via HART)			
General Purpose	10mA ^①	11V	36V
Intrinsically Safe	10mA ^①	11V	28.6V
HART Multi-Drop Mode (Fixed Current)			
Standard	4mA ^①	16.25V	36V
Intrinsically Safe1	4mA ^①	16.25V	28.6V
FOUNDATION fieldbus			
Supply Voltage	9V to 17.5V	9V to 17.5V	9V to 17.5V

① Start-up current 12mA minimum.

5.8 Model Number

Transmitter

1 2 3 | BASIC MODEL NUMBER

JM4	Jupiter 4th Generation Magnetostrictive Level Transmitter
-----	---

4 | POWER

5	24 VDC Two-Wire
---	-----------------

5 | SIGNAL OUTPUT

1	4-20 mA with HART®
2	FOUNDATION fieldbus™ Communications

6 | SAFETY OPTIONS

0	None required for FOUNDATION fieldbus™
1	SIL 2/3 Certified - HART only <small>SEE NOTE 1</small>

¹ SIL certificate and FMEDA report available

7 | ACCESSORIES/MOUNTING

0	No Digital Display and Keypad - Integral
1	No Digital Display and Keypad - Remote 36" (0.91m) <small>SEE NOTE 2</small>
2	No Digital Display and Keypad - Remote 144" (3.6m) <small>SEE NOTE 2</small>
A	Digital Display and Keypad - Integral
B	Digital Display and Keypad - Remote 36" (0.91m) <small>SEE NOTE 2</small>
C	Digital Display and Keypad - Remote 144" (3.6m) <small>SEE NOTE 2</small>

² Remote mount transmitter is not available with Digit 8 = 3, B, or D

8 | AREA CLASSIFICATION

0	General Purpose, Weatherproof (IP66 & IP67)
1	Intrinsically Safe / FISCO (cFMus)
3	Explosion-Proof / FNICO (cFMus)
A	Intrinsically Safe (ATEX & IEC)
B	Flame-Proof (ATEX & IEC)
C	Non-Incendive
D	Dust Ignition Proof

9 | HOUSING

1	Aluminum, Dual-Component
2	Stainless Steel, Dual-Component

10 | CONDUIT CONNECTION

0	½" NPT
1	M20
2	½" NPT with Sunshade
3	M20 with Sunshade

J	M	4
1	2	3

5			
4	5	6	7

8	9	10

Model Number

External Mount Probe

1 | TECHNOLOGY

2	Jupiter Magnetostrictive Probes - Model JM4
---	---

2 | MEASUREMENT SYSTEM

A	English <i>Probe length to be provided in inches</i>
C	Metric <i>Probe length to be provided in centimeters</i>

3 | CONFIGURATION

E	STANDARD Top Mount	<i>suitable for process temperatures -40 to +500 °F (-40 to +260 °C) <small>SEE NOTE 1</small></i>
F	STANDARD Top Mount Offset	
H	STANDARD Bottom Mount Offset	
K	HIGH-TEMP Top Mount	<i>suitable for process temperatures +501 to +850 °F (+261 to +454 °C) <small>SEE NOTE 1</small></i>
L	HIGH-TEMP Top Mount Offset	
M	HIGH-TEMP Bottom Mount Offset	
R	CRYOGENIC Top Mount	<i>suitable for process temperatures -320 to +150 °F (-196 to +66 °C)</i>
S	CRYOGENIC Top Mount Offset	
T	CRYOGENIC Bottom Mount Offset	

¹ MLI insulation required for maximum temperature

4 5 | MOUNTING SIDE

0 0	Left-side MLI Mount
0 1	Right-side MLI Mount

6 | PROBE MATERIAL OF CONSTRUCTION

A	Powder-Coated Aluminum Sensor Enclosure with 316 SS Probe <small>SEE NOTE 2</small>
1	316 SS Sensor Enclosure with 316 SS Probe

² Available only with Digit 3, Options F, H, L, M

7 | PROBE OPTIONS AND HAZARDOUS LOCATION APPROVALS

Standard Probe	
F	ATEX & IEC Flameproof approval only
N	All other approvals (XP, IS, NI)

Vibration Resistant Probe <small>SEE NOTE 3</small>	
G	ATEX & IEC Flameproof approval only
V	All other approvals (XP, IS, NI)

³ Available only with Digit 3, Options F, H, L, M

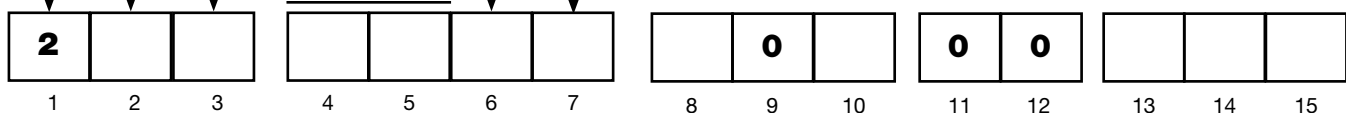

Model Number (continued)

External Mount Probe

8 | CHAMBER SIZE (FOR MOUNTING HARDWARE)

0	No mounting clamps required.
---	------------------------------

Select from these options if chamber DOES NOT contain high-temp insulation

1	2" (or if digit 20 of MLI model code is 1, 2, or 7)
2	2½" (or if digit 20 of MLI model code is 3, 4, 5, or 6)
3	3" (or if digit 20 of MLI model code is A, B, C, or D)
4	4" (or if digit 20 of MLI model code is E, F, G, H, or J)
5	¾" (for Atlas Top Mount Configuration only)

Select from these options if chamber DOES contain high-temp insulation

E	2" (or if digit 20 of MLI model code is 1, 2, or 7)
F	2½" (or if digit 20 of MLI model code is 3, 4, 5, or 6)
G	3" (or if digit 20 of MLI model code is A, B, C, or D)
H	4" (or if digit 20 of MLI model code is E, F, G, H, or J)
J	¾" (for Atlas Top Mount Configuration only)

10 | LEVEL/INTERFACE MEASUREMENT PREFERENCE

1	Measure Only the Total Liquid Level
2	Measure Only the Interface Level
3	Measure Both Total and Interface Level

13 14 15 | PROBE LENGTH SEE NOTE 4

X X X	Example: 87 inches = 087 <i>Code 2 must be "A"</i> Example: 120 centimeters = 120 <i>Code 2 must be "C"</i>
-------	--

⁴ Maximum Probe Length = 400 inches (999 cm)
(limited to 180 inches (457 cm) when digit 3 = K, L or M)

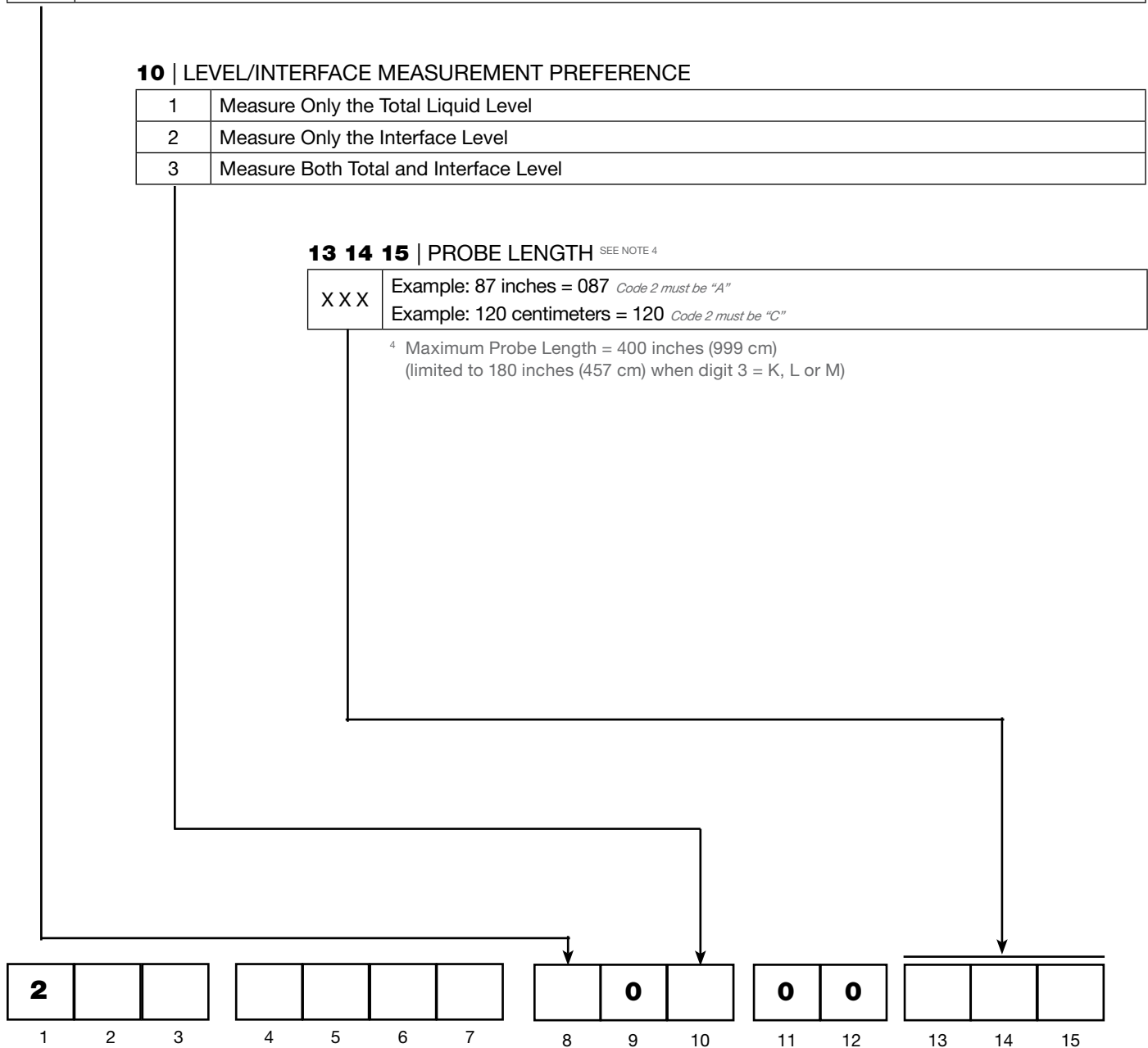

Model Number

Direct Insertion Probe

1 | TECHNOLOGY

2	Jupiter Magnetostrictive Probes - Model JM4
---	---

2 | MEASUREMENT SYSTEM

A	English <i>Probe length to be provided in inches</i>
C	Metric <i>Probe length to be provided in centimeters</i>

3 | CONFIGURATION

1	Standard	<i>process temperatures between -40 to +500 °F (-40 to +260 °C)</i>
2	High-Temperature	<i>process temperatures between +501 to +800 °F (+261 to +427 °C)</i>
8	Cryogenic	<i>process temperatures between -320 to +150 °F (-196 to +66 °C)</i>

4 & 5 | PROCESS CONNECTION SIZE & TYPE

Threaded

11	3/4" NPT	22	1" BSP
41	2" NPT	42	2" BSP

ASME Flanges

43	2" 150# Raised Face	56	3" 900# Raised Face
44	2" 300# Raised Face	57	3" 1500# Raised Face
45	2" 600# Raised Face	63	4" 150# Raised Face
47	2" 900/1500# Raised Face	64	4" 300# Raised Face
53	3" 150# Raised Face	65	4" 600# Raised Face
54	3" 300# Raised Face	66	4" 900# Raised Face
55	3" 600# Raised Face	67	4" 1500# Raised Face

EN 1092-1 Flanges

CB	DN 40 : PN 16/25/40 Type A	ED	DN 80 : PN 63 Type B2
CC	DN 40 : PN 63/100 Type B2	EE	DN 80 : PN 100 Type B2
DA	DN 50 : PN 16 Type A	FA	DN 100 : PN 16 Type A
DB	DN 50 : PN 25/40 Type A	FB	DN 100 : PN 25/40 Type A
DD	DN 50 : PN 63 Type B2	FD	DN 100 : PN 63 Type B2
DE	DN 50 : PN 100 Type B2	FE	DN 100 : PN 100 Type B2
EA	DN 80 : PN 16 Type A	FF	DN 100 : PN 160 Type B2
EB	DN 80 : PN 25/40 Type A	FG	DN 100 : PN 250 Type B2

6 | MATERIAL OF CONSTRUCTION

A	316 SS
B	Hastelloy C276
C	Monel 400
L	316 SS w/Teflon-S coating on probe tubing and float <small>SEE NOTES 1 & 2</small>
P	316 SS w/PFA coating on probe tubing and float <small>SEE NOTE 2</small>

¹ Teflon coating intended for slip resistance.

² ID of float to be enlarged to accommodate coating.

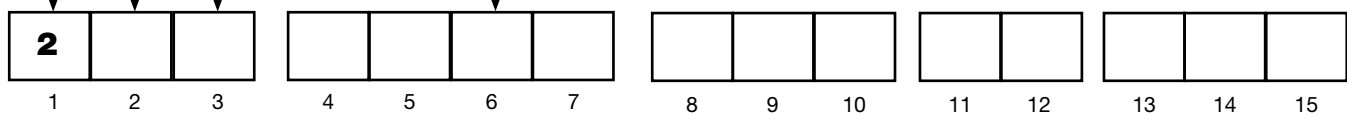

Model Number (continued)

Direct Insertion Probe

7 | PROBE OPTIONS AND HAZARDOUS LOCATION APPROVALS

F	ATEX & IEC Flameproof approval only
N	All other approvals (XP, IS, NI)

8 | INSTALLATION CONSIDERATIONS

N	Direct Insertion unit mounted in vessel without stilling well
C	Direct Insertion unit mounted in chamber, bridle, or stilling well <small>SEE NOTE 3</small>

³ Refer to sizing chart for chambers and stilling wells on page 16 of bulletin ORI-150.

9 | CONSTRUCTION CODE

0	Industrial Grade
K	ASME B31.1
L	ASME B31.3
M	ASME B31.3 & NACE MR0103/MR0175
N	Industrial Grade & NACE MR0103/MR0175

10 | LEVEL/INTERFACE MEASUREMENT PREFERENCE

1	Measure Only the Total Liquid Level
2	Measure Only the Interface Level
3	Measure Both Total and Interface Level

11 12 | MAGNETIC FLOAT(S)

See next page for our standard direct insertion float offerings. If a listed float does not meet your application requirements, consult factory for a custom design.

13 14 15 | PROBE LENGTH SEE NOTE 4

X X X	Example: 87 inches = 087 <i>Code 2 must be "A"</i> Example: 120 centimeters = 120 <i>Code 2 must be "C"</i>
-------	--

⁴ Maximum Probe Length = 240 inches (610 cm); consult factory for longer lengths (limited to 180 inches (457 cm) when digit 3 = 2)

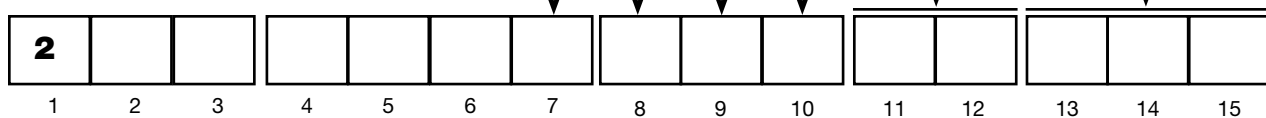

Model Number Continued

Direct Insertion Probe — Float Selection

11 12 | MAGNETIC FLOAT(S)

Direct Insertion Total Level Float (uppermost liquid layer)

Minimum Liquid Specific Gravity	316/316L SS	Titanium	Hastelloy® C	Hygienic Service 316/316L SS SF1: 20 µin (0.51 µm)	Hygienic Service 316/316L SS SF4: 15 µin (0.38 µm)
≥ 0.86	AA 2.0" (51 mm) dia.	BA 2.0" (51 mm) dia.	CA 1.85" (47 mm) dia.	DA 2.0" (51 mm) dia.	FA 2.0" (51 mm) dia.
≥ 0.83	AA 2.0" (51 mm) dia.	BA 2.0" (51 mm) dia.	CB 2.25" (57 mm) dia.	DA 2.0" (51 mm) dia.	FA 2.0" (51 mm) dia.
≥ 0.7	AB 2.3" (58 mm) dia.	BA 2.0" (51 mm) dia.	CB 2.25" (57 mm) dia.	DB 2.3" (58 mm) dia.	FB 2.3" (58 mm) dia.
≥ 0.68	AB 2.3" (58 mm) dia.	BB 2.25" (57 mm) dia.	99 consult factory	DB 2.3" (58 mm) dia.	FB 2.3" (58 mm) dia.
≥ 0.64	AC 2.5" (64 mm) dia.	BB 2.25" (57 mm) dia.	99 consult factory	DC 2.5" (64 mm) dia.	FC 2.5" (64 mm) dia.
≥ 0.52	99 consult factory dia.	BB 2.25" (57 mm) dia.	99 consult factory	99 consult factory	99 consult factory
< 0.52	99 consult factory	99 consult factory	99 consult factory	99 consult factory	99 consult factory

Direct Insertion Interface Level Float (lower or middle liquid layer)

Minimum Liquid Specific Gravities upper / lower	316/316L SS	Titanium	Hastelloy® C	Hygienic Service 316/316L SS SF1: 20 µin (0.51 µin)	Hygienic Service 316/316L SS SF4: 15 µin (0.38 µin)
sinks thru / floats on ≤ 0.89 / ≥ 1.00	MA 2.0" (51 mm) dia.	NA 2.0" (51 mm) dia.	PA 1.85" (47 mm) dia.	QA 2.0" (51 mm) dia.	RA 2.0" (51 mm) dia.
sinks thru / floats on ≤ 1.00 / ≥ 1.12	MB 2.0" (51 mm) dia.	NB 2.0" (51 mm) dia.	PB 1.85" (47 mm) dia.	QB 2.0" (51 mm) dia.	RB 2.0" (51 mm) dia.

Two Floats for Total Level and Interface Measurement

Code	Total	Interface
11	AA	MA
12	AB	
13	AC	
21	AA	MB
22	AB	
23	AC	
31	BA	NA

Code	Total	Interface
32	BB	NA
41	BA	NB
42	BB	
51	CA	PA
52	CB	
61	CA	PB
62	CB	

When utilizing two floats to measure total and interface liquid levels, reference the above chart to determine the appropriate float code to insert into the Jupiter model number.

If the desired combination is not shown, consult your local sales representative or AMETEK LMS to inquire about a custom float design.

Appendix A

Level (and Interface) Transducer Block Table

Item	Parameter Name	Parameter Label
0	BLOCK_STRUCTURE	BLOCK STRUCT
1	ST_REV	Static Revision
2	TAG_DESC	Tag Description
3	STRATEGY	Strategy
4	ALERT_KEY	Alert Key
5	MODE_BLK	Block Mode
6	BLOCK_ERR	Block Error
7	UPDATE_EVT	Update Event
8	BLOCK_ALM	Block Alarm
9	TRANSDUCER_DIRECTORY	Transducer Directory
10	TRANSDUCER_TYPE	Transducer Type
11	XD_ERROR	Transducer Error
12	COLLECTION_DIRECTORY	Collection Directory
13	MEAS_TYPE	Measurement Type
14	LEVEL	Level
15	LEVEL_UNIT	Level Unit
16	DISTANCE	Distance
17	DISTANCE_UNIT	Distance Unit
18	PROBE_MODEL_NUM	Probe M/N
19	PROBE_SER_NUM	Probe S/N
20	PROBE_CONFIG	Probe Configuration
21	PROBE_TYPE	Probe Type
22	PROBE_LENGTH	Probe Length
23	PROBE_TEMP_RATING	Probe Temp Rating
24	PROBE_VIBRATION_RATING	Probe Vibration Rating
25	PROBE_FLOATMINSEP	Probe Minimum Separation
26	PROBE_SENSITIVITY	Probe Sensitivity
27	PROBE_LEVEL_THRESHOLD_MODE	Probe Level Threshold Mode
28	PROBE_LEVEL_SLOPED_START_AMPL	Probe Level Sloped Start Value
29	PROBE_LEVEL_THRESHOLD_VALUE	Probe Level Threshold Value
30	PROBE_IFC_LEVEL_THRESH_MODE	Ifc Level Thresh Mode
31	PROBE_IFC_SLOPED_START_AMPL	Ifc Sloped Start Value
32	PROBE_IFC_LEVEL_THRESH_VALUE	Ifc Level Thresh Value
33	PROBE_SLOPED_END_DISTANCE	Sloped End Distance
34	PROBE_UPR_LVL_POLARITY	Probe Upr Lvl Polarity
35	PROBE_IFC_LVL_POLARITY	Probe Ifc Level Polarity
36	RESET_NEW_PROBE_DIAGNOSTIC	Reset New Probe Diagnostic
37	PROBE_CONV_FACT	Probe Conversion Factor
38	PROBE_SCLE_OFFS	Probe Scale Offset

39	PROBE_DRIVE_PLUS_COUNTS	Probe Drive+ Counts
40	PROBE_WAIT_COUNTS	Probe Wait Counts
41	PROBE_DRIVE_MINUS_COUNTS	Probe Drive- Counts
42	PROBE_CAL_DATE	Probe Cal Date
43	PROBE_CAL_LOC	Probe Cal Location
44	PARAMETER_5	Parameter 5
45	PARAMETER_6	Parameter 6
46	LEVEL_OFFSET	Level Offset
47	ZERO_OFFSET	Zero Offset
48	SENSITIVITY	Sensitivity
49	BLOCKING_DISTANCE	Blocking Distance
50	ALARM_DELAY	Failure Alarm Delay
51	LEVEL_TRIM	Level Trim
52	LEVEL_THRESHOLD_MODE	Level Threshold Mode
53	LEVEL_THRESHOLD_VALUE	Level Threshold Value
54	UPR_LVL_POLARITY	Level Polarity
55	FLOATMINSEP	Minimum Separation
56	LEVEL_SLOPED_START_AMPL	Level Sloped Start Value
57	SLOPED_END_DISTANCE	Sloped End Distance
58	INTERFACE_LEVEL	Interface Level
59	INTERFACE_LEVEL_UNIT	Interface Level Unit
60	UPPER_THICKNESS	Upper Thickness
61	UPPER_THICKNESS_UNIT	Upper Thickness Unit
62	IFC_LEVEL_TRIM	Ifc Level Trim
63	IFC_LEVEL_THRESH_MODE	Ifc Level Thresh Mode
64	IFC_LEVEL_THRESH_VALUE	Ifc Level Thresh Value
65	IFC_LVL_POLARITY	Ifc Level Polarity
66	IFC_SLOPED_START_AMPL	Ifc Sloped Start Value
67	RESET_PARAMETERS	Reset Parameters
68	LEVEL_TICKS	Level Ticks
69	ECHO_STRENGTH	Echo Strength
70	INTERFACE_TICKS	Interface Ticks
71	IFC_ECHO_STRENGTH	Ifc Echo Strength
72	LEVEL_NOISE_RATIO	Level Noise Ratio
73	LEVEL_NOISE_LOCATION	Level Noise Location
74	IFC_NOISE_RATIO	Ifc Noise Ratio
75	IFC_NOISE_LOCATION	Ifc Noise Location
76	ELECTRONICS_TEMPERATURE	Electronics Temp
77	TEMPERATURE_UNIT	Temperature Unit
78	MAX_ELECTRONICS_TEMP	Max Elec Temp
79	MIN_ELECTRONICS_TEMP	Min Elec Temp

80	RESET_ELECTRONICS_TEMPS	Reset Electronic Temps
81	ENTER_PASSWORD	Enter Password
82	ELEC_TEMP_OFFSET	Elec Temp Offset
83	NAP_VALUE	NAP Value
84	FACTORY_RESET	Factory Reset
85	CONV_FACT	Conversion Factor
86	SCLE_OFFS	Scale Offset
87	DRIVE_PLUS_COUNTS	Drive+ Counts
88	WAIT_COUNTS	Wait Counts
89	DRIVE_MINUS_COUNTS	Drive- Counts
90	FACTORY_PARAMETER_1	Factory Parameter 1
91	FACTORY_PARAMETER_2	Factory Parameter 2
92	FACTORY_PARAMETER_3	Factory Parameter 3
93	FACTORY_PARAMETER_4	Factory Parameter 4
94	MAGNETROL_SERIAL_NUMBER	Magnetrol S/N
95	DATE_CODE	Date Code
96	CONFIG_CHANGED_MODE	TB Config Chgd Mode
97	RESET_CONFIG_CHANGED	Reset Config Changed
98	USER_PASSWORD	New User Password
99	LOCAL_DISP_MEAS_VALUES	Local Disp Meas Values
100	LOCAL_DISP_LANGUAGE	Local Disp Language
101	LOCAL_DISP_PHYS_DEV_TAG	Local Disp Phys Dev Tag
102	MAIN_FIRMWARE_VERSION	Main Firmware Version
103	MAIN_HARDWARE_VERSION	Main Hardware Version
104	COP_FIRMWARE_VERSION	CoP Firmware Version
105	COP_HARDWARE_VERSION	CoP Hardware Version
106	PRESENT_STATUS	Present Status
107	STATUS_INDICATORS_1	Indicators Group 1
108	STATUS_INDICATORS_2	Indicators Group 2
109	STATUS_INDICATORS_3	Indicators Group 3
110	STATUS_INDICATORS_4	Indicators Group 4
111	STATUS_INDICATORS_5	Indicators Group 5
112	STATUS_INDICATORS_6	Indicators Group 6
113	TREND_LEVEL_VALUE	Level
114	TREND_DISTANCE_VALUE	Distance
115	TREND_IFC_LEVEL_VALUE	Interface Level
116	TREND_UPPER_THICK_VALUE	Upper Thickness
117	TREND_ECHO_STR_VALUE	Echo Strength
118	TREND_IFC_ECHO_STR_VALUE	Ifc Echo Strength
119	DEVICE_CLOCK	Device Clock

120	HISTORY_CONTROL	History Control
121	HIST_ENTRY1	Event History 1
122	HIST_ENTRY2	Event History 2
123	HIST_ENTRY3	Event History 3
124	HIST_ENTRY4	Event History 4
125	HIST_ENTRY5	Event History 5
126	HIST_ENTRY6	Event History 6
127	HIST_ENTRY7	Event History 7
128	HIST_ENTRY8	Event History 8
129	HIST_ENTRY9	Event History 9
130	HIST_ENTRY10	Event History 10
131	RESET_HISTORY	Reset History
132	ECHO_HIST_TRIGGER_MODE	Echo Hist Trigger Mode
133	ECHO_HIST_TIME_TRIGGERS	Echo Hist Time Triggers
134	ECHO_HIST_EVENT_TRIGGERS	Echo Hist Event Triggers
135	ECHO_REFERENCE_LOG	Echo Reference
136	ECHO_HISTORY_LOG1	Echo History 1
137	ECHO_HISTORY_LOG2	Echo History 2
138	ECHO_HISTORY_LOG3	Echo History 3
139	ECHO_HISTORY_LOG4	Echo History 4
140	ECHO_HISTORY_LOG5	Echo History 5
141	ECHO_HISTORY_LOG6	Echo History 6
142	ECHO_HISTORY_LOG7	Echo History 7
143	ECHO_HISTORY_LOG8	Echo History 8
144	ECHO_HISTORY_LOG9	Echo History 9
145	DELETE_ECHO_HISTORY	Delete Echo History
146	SAVE_ECHO_CURVE	Save Echo Curve
147	VIEW_ECHO_CURVE	View Echo Curve
148	WAVEFORM_SUMMARY	Waveform Summary
149	ECHO_CURVE_DATA	Echo Curve Data
150	ECHO_DATA_INDEX	Echo Data Index
151	DATA_LOG_SETUP	Data Log Setup
152	DATA_LOG_SUMM_READ_REQ	Log Summary Read Req
153	DATA_LOG_SUMMARY	Data Log Summary
154	DATA_LOG_INDEX	Data Log Index
155	DATA_LOG_RECORDS	Log Data
156	PD_TAG_APPL_IMAGE	PD Tag

Level (and Interface) Transducer Block Table

Item	Parameter Name	Parameter Label
0	BLOCK_STRUCTURE	BLOCK STRUCT
1	ST_REV	Static Revision
2	TAG_DESC	Tag Description
3	STRATEGY	Strategy
4	ALERT_KEY	Alert Key
5	MODE_BLK	Block Mode
6	BLOCK_ERR	Block Error
7	UPDATE_EVT	Update Event
8	BLOCK_ALM	Block Alarm
9	TRANSDUCER_DIRECTORY	Transducer Directory
10	TRANSDUCER_TYPE	Transducer Type
11	XD_ERROR	Transducer Error
12	COLLECTION_DIRECTORY	Collection Directory
13	MEAS_TYPE	Measurement Type
14	VOLUME	Volume
15	VOLUME_UNIT	Volume Unit
16	FILL_RATE	Fill Rate
17	FILL_RATE_UNIT	Fill Rate Unit
18	LEVEL_VALUE	Level
19	LEVEL_UNIT	Level Unit
20	VESSEL_TYPE	Vessel Type
21	VESSEL_RADIUS	Vessel Radius
22	VESSEL_ELLIPSE_DEPTH	Vessel Ellipse Depth
23	VESSEL_CONICAL_HEIGHT	Vessel Conical Height
24	VESSEL_WIDTH	Vessel Width
25	VESSEL_LENGTH	Vessel Length
26	VOLUME_TABLE_TYPE	Volume Table Type
27	LEVEL_INPUT_SOURCE	Level Input Source
28	VOLUME_TABLE_LENGTH	Volume Table Length
29	VOLUME_TABLE_PT_01	Volume Table Pt 01
30	VOLUME_TABLE_PT_02	Volume Table Pt 02
31	VOLUME_TABLE_PT_03	Volume Table Pt 03
32	VOLUME_TABLE_PT_04	Volume Table Pt 04
33	VOLUME_TABLE_PT_05	Volume Table Pt 05
34	VOLUME_TABLE_PT_06	Volume Table Pt 06
35	VOLUME_TABLE_PT_07	Volume Table Pt 07
36	VOLUME_TABLE_PT_08	Volume Table Pt 08
37	VOLUME_TABLE_PT_09	Volume Table Pt 09
38	VOLUME_TABLE_PT_10	Volume Table Pt 10

39	VOLUME_TABLE_PT_11	Volume Table Pt 11
40	VOLUME_TABLE_PT_12	Volume Table Pt 12
41	VOLUME_TABLE_PT_13	Volume Table Pt 13
42	VOLUME_TABLE_PT_14	Volume Table Pt 14
43	VOLUME_TABLE_PT_15	Volume Table Pt 15
44	VOLUME_TABLE_PT_16	Volume Table Pt 16
45	VOLUME_TABLE_PT_17	Volume Table Pt 17
46	VOLUME_TABLE_PT_18	Volume Table Pt 18
47	VOLUME_TABLE_PT_19	Volume Table Pt 19
48	VOLUME_TABLE_PT_20	Volume Table Pt 20
49	VOLUME_TABLE_PT_21	Volume Table Pt 21
50	VOLUME_TABLE_PT_22	Volume Table Pt 22
51	VOLUME_TABLE_PT_23	Volume Table Pt 23
52	VOLUME_TABLE_PT_24	Volume Table Pt 24
53	VOLUME_TABLE_PT_25	Volume Table Pt 25
54	VOLUME_TABLE_PT_26	Volume Table Pt 26
55	VOLUME_TABLE_PT_27	Volume Table Pt 27
56	VOLUME_TABLE_PT_28	Volume Table Pt 28
57	VOLUME_TABLE_PT_29	Volume Table Pt 29
58	VOLUME_TABLE_PT_30	Volume Table Pt 30
59	VOLUME_HIGH_LIMIT	Volume High Limit
60	LEVEL_LOW_LIMIT	Level Low Limit
61	LEVEL_HIGH_LIMIT	Level High Limit
62	ENTER_PASSWORD	Enter Password
63	PRESENT_STATUS	Present Status
64	STATUS_INDICATORS_1	Indicators Group 1
65	STATUS_INDICATORS_2	Indicators Group 2
66	STATUS_INDICATORS_3	Indicators Group 3
67	STATUS_INDICATORS_4	Indicators Group 4
68	STATUS_INDICATORS_5	Indicators Group 5
69	STATUS_INDICATORS_6	Indicators Group 6
70	TREND_VOLUME_VALUE	Volume

NOTES

Service Policy

Owners of AMETEK LMS controls may request the return of a or any part of an instrument for complete rebuilding or replacement. They will be rebuilt or replaced promptly. Instruments returned under our service policy must be returned by prepaid transportation.

AMETEK LMS will repair or replace the control at no cost to the purchaser (or owner) other than transportation if:

1. Returned within the warranty period; and
2. The factory inspection finds the cause of the claim to be covered under the warranty.

If the trouble is the result of conditions beyond our control; or, is NOT covered by the warranty, there will be charges for labor and the parts required to rebuild or replace the equipment.

In some cases it may be expedient to ship replacement parts; or, in extreme cases a complete new instrument, to replace the original equipment before it is returned. If this is desired, notify the factory of both the model and serial numbers of the instrument to be replaced. In such cases, credit for the materials returned will be determined on the basis of the applicability of our warranty.

No claims for misapplication, labor, direct or consequential damage will be allowed.

Return Material Procedure

So that we may efficiently process any materials that are returned, it is essential that a "Return Material Authorization" (RMA) number be obtained from the factory, prior to the material's return. This is available through an AMETEK LMS local representative or by contacting the factory. Please supply the following information:

1. Company Name
2. Description of Material
3. Serial Number
4. Reason for Return
5. Application

Any unit that was used in a process must be properly cleaned in accordance with OSHA standards, before it is returned to the factory.

A Material Safety Data Sheet (MSDS) must accompany material that was used in any media.

All shipments returned to the factory must be by prepaid transportation.

All replacements will be shipped F.O.B. factory.

