

L-Series: LIQUID LEVEL FLOAT SWITCH

L001, L002, L003, L170, L175, L176,
L177, L178, L180, L190 AND L195

INSTALLATION AND OPERATIONS MANUAL

Single-Point, Vertically-Mounted Liquid Level Float Switch



ISO 9001:2008 CERTIFIED



This manual provides information on the **L-Series, Single-Point, Vertically-Mounted Liquid Level Float Switch**. It is important that all instructions are read carefully and followed sequentially. Detailed instructions are included in the **Complete Installation** section of this manual.

Conventions Used in this Manual

Certain conventions are used in this manual to convey specific types of information. General technical material, support data and safety information are presented in narrative form. The following styles are used for notes, cautions and warnings:

Notes

Notes contain information that augments or clarifies an operating step. Notes do not normally contain actions and often follow the procedural steps to which they refer.

Cautions

Cautions alert the technician to special conditions that could injure personnel, damage equipment, or reduce a component's mechanical integrity. Cautions are also used to alert the technician of unsafe practices, the need for special protective equipment, or specific materials. In this manual, a caution indicates a potentially hazardous situation which, if not avoided, may result in minor to moderate injury.

Notice of Copyright and Limitations

Copyright ©2022 AMETEK Magnetrol USA, LLC
All rights reserved.

Solutions With Innovation reserves the right to make changes to the product described in this manual at any time without notice. Solutions With Innovation makes no warranty with respect to the accuracy of the information in this manual.

Warranty

All Solutions With Innovation Mechanical Level and Flow Controls are warranted free of defects in materials and workmanship for one full year from the date of the original factory shipment. If returned within the warranty period; and, upon factory inspection of the control, the cause of the claim is determined to be covered under the warranty; then, Solutions With Innovation will repair or replace the product at no cost to the purchaser (or owner) other than transportation.

Solutions With Innovation shall not be liable for misapplication, labor claims, direct or consequential damage, or expenses arising from the installation or use of the equipment. There are no other warranties expressed or implied, except special written warranties covering specific Solutions With Innovation products.

Quality Assurance

The Quality Assurance System in place at Solutions With Innovation guarantees the highest level of quality throughout the company. Solutions With Innovation is committed to providing full customer satisfaction; both in quality products and in quality service.

Contacts

Phone: 203-729-6434 *Mon-Fri, 9 AM - 5 PM EST* Fax:
203-729-0541 *for General Inquiries*
Email: ct-nau-info@ametek.com

L-Series: LIQUID LEVEL FLOAT SWITCH

L001, L002, L003, L170, L175, L176,
L177, L178, L180, L190 AND L195 Single-Point, Vertical Mount

TABLE OF CONTENTS

1.0 Installation

- 1.1 Unpacking.....4
- 1.2 Before You Begin.....4
 - 1.2.1 Site Preparation.....4
 - 1.2.2 Equipment and Tools.....4
- 1.3 Mounting.....5
 - 1.3.1 Threaded Mounting.....5
- 1.4 Wiring.....5

2.0 Preventative Maintenance

- 2.1 What To Do.....6
 - 2.1.1 Inspect Entire Unit Periodically.....6
 - 2.1.2 Inspect Connections Monthly.....6
 - 2.1.3 Keep Unit Clean.....6
- 2.2 What To Avoid.....6

3.0 Reference Information

- 3.1 Description.....7
- 3.2 Theory of Operation.....7
- 3.3 Troubleshooting.....7
 - 3.3.1 External Causes.....7
 - 3.3.2 Unit Causes.....8
- 3.4 Agency Approvals.....8
- 3.5 Specifications.....9
 - 3.5.1 Physical Specifications.....9
 - 3.5.2 Electrical Specifications.....9
 - 3.5.3 Dimensional Specifications.....10
- 3.6 Notes.....10
- 3.7 Model Configurator.....11
- 3.8 Replacement Parts.....11



1.0 INSTALLATION

This section provides detailed procedures on properly installing the L-Series Single-Point, Vertically-Mounted Liquid Level Float Switch.

 **CAUTION!** IF THE EQUIPMENT IS USED IN A MANNER NOT SPECIFIED BY THE MANUFACTURER, PROTECTION PROVIDED BY THE EQUIPMENT MAY BE IMPAIRED.

1.1 UNPACKING

Unpack the instrument, carefully. Make sure that all components have been removed from the packing material. Inspect all components for damage. Report any concealed damage to the carrier within 24 hours of receiving. Compare the contents with the packing slip and report any discrepancies to the factory immediately. Record the sales order number and/or serial number for future reference when ordering parts.

Before Proceeding to Installation, Complete the Following:

- Inspect all components for damage. Report any damage to the carrier within 24 hours of receiving.
- Record the model and serial numbers for future reference when ordering parts.

Model Number _____

Serial Number _____

1.2 BEFORE YOU BEGIN

 **CAUTION!** DURING THE INSTALLATION OF THE SINGLE-POINT, VERTICALLY-MOUNTED LIQUID LEVEL SWITCH, THE FLOAT AREA MUST BE KEPT FREE OF METALLIC PARTICLES THAT MIGHT BE ATTRACTED TO THE FLOAT'S INTERNAL MAGNET.

1.2.1 Site Preparation

Ensure that the length and the inside diameter of the mounting is sized correctly to accommodate the L-Series Single-Point, Vertically-Mounted Liquid Level Float Switch.

1.2.2 Equipment and Tools

No special equipment or tools are required to install the L-Series Single-Point, Vertically-Mounted Liquid Level Float Switch.

The Following Are Recommended:

- Wrenches, thread sealant, gaskets and/or bolting as required for the process connection.

1.3 MOUNTING

The L-Series Single-Point, Vertically-Mounted Liquid Level Float Switch is available in a variety of threaded mountings. These devices can be installed from the bottom or top of the tank. The switches should be mounted in an area clear of turbulence or direct streams.

1.3.1 Threaded Mounting

How to Install an L-Series Single-Point, Vertically-Mounted Liquid Level Switch:

- 1 Apply either Teflon[®] tape or an appropriate thread sealant to the mounting threads to prevent galling.
- 2 Engage the thread by hand to avoid unnecessary damage.
- 3 Using a wrench, rotate the unit clockwise until it is tight within the mounting.

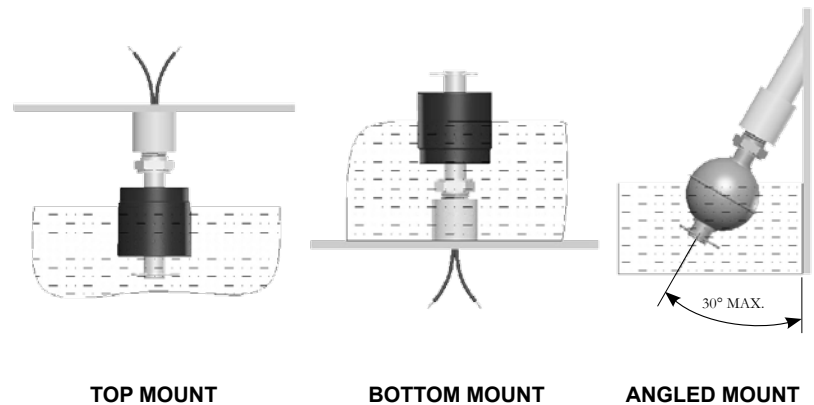

1.4 WIRING

CAUTION! OBSERVE ALL APPLICABLE ELECTRICAL CODES AND PROPER WIRING PROCEDURES.

SPST Reed Switch:

- 1 Connect the wiring to the red switch leads or terminals, as illustrated below.

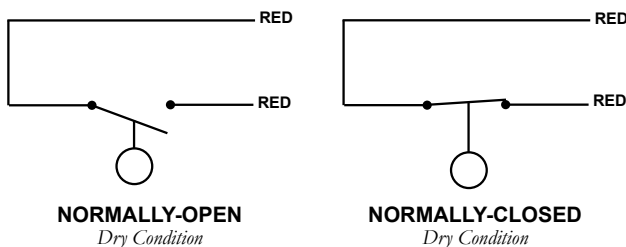

SPDT Reed Switch:

- 1 Connect the wiring to the proper switch leads or terminals, as illustrated below.

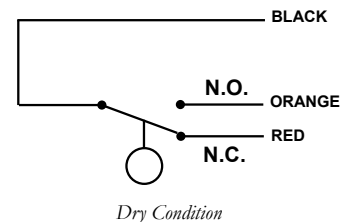

Contact Protection:

In order to maintain the life and reliability of the internal reed switch, it is essential to provide protection when switching inductive loads. When the current breaks, the energy stored in the load generates a high frequency voltage across the switch contacts. If the voltage is large enough, it can initiate arcing and cause the contacts to weld together. Damage can ultimately be prevented by suppressing the voltage. Through the use of a diode for DC circuits and a resistor-capacitor network for AC circuits, contact protection will ensure reliable performance from the reed switch.

2.0 PREVENTATIVE MAINTENANCE

Periodic inspections are necessary to maintain the proper functionality of the L-Series Single-Point, Vertically-Mounted Liquid Level Switch. The switch is a safety device that protects the equipment it serves. A systematic program of preventative maintenance should be implemented at the time of installation. If the following instructions are completed routinely, the switch will provide continuous, reliable protection.

2.1 MAINTENANCE PROCEDURES

2.1.1 Inspect Unit Periodically

Verify that there are no cracks or chipped surfaces on the float or stem. Should the unit become damaged, obtain a replacement immediately.

2.1.2 Inspect Connections Monthly

L-Series Single-Point, Vertically-Mounted Liquid Level Switches may be vulnerable to excessive heat and moisture. Under these conditions, the electrical wire insulation can periodically break or peel away. As a result, the bare wires may become exposed to the elements and cause damages.

- Inspect all wiring, carefully and replace any wires exhibiting signs of brittle insulation.
- Inspect all electrical connections to ensure tightness.
- Repair or replace any wiring, if necessary.

2.1.3 Keep Unit Clean

Periodic cleanings of the float, stem and magnet assembly will ensure the continual, uninterrupted movement of the mechanism. Always keep the open area between the enclosures clean and free of any potential interferences. Objects and debris may cause systematic interruptions and a loss in equipment functionality.

2.2 WHAT TO AVOID



NEVER LEAVE THE SWITCH WIRING EXPOSED TO THE ELEMENTS.



NEVER PLACE A JUMPER WIRE ACROSS THE TERMINALS TO “CUT-OUT” THE CONTROL. *If a jumper is necessary for testing purposes, ensure that it is removed prior to placing the control into service.*



NEVER USE IN SYSTEMS CONTAINING IRON PARTICLES. *The magnet within the float assembly can attract the particles and become jammed.*

3.0 REFERENCE INFORMATION

This section illustrates an overview of the L-Series Single-Point, Vertically-Mounted Liquid Level Switch, as well as information on troubleshooting common problems, agency approval listings, and detailed physical, functional and performance specifications.

3.1 DESCRIPTION

The L-Series Single-Point, Vertically-Mounted Liquid Level Switch is a float-actuated device designed to be vertically mounted within a tank or process vessel through threaded connections. The low-cost switch is ideal for OEM applications where a single-point high or low level alarm is desired.

3.2 THEORY OF OPERATION

The switching action is achieved through the use of an internal magnet within the float assembly and its interaction with the switch mechanism. As the liquid level fluctuates inside the tank, the float follows. Its magnetic field actuates the switch inside the stem and closes an electrical circuit.

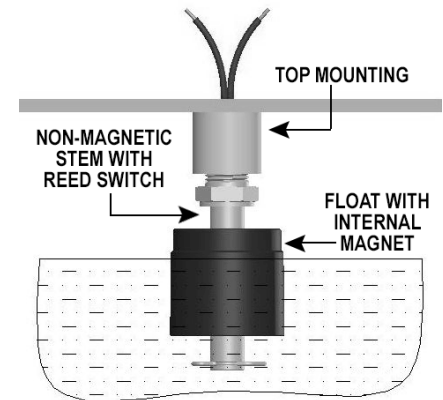

FLOAT SWITCH DIAGRAM

3.3 TROUBLESHOOTING

The L-Series Single-Point, Vertically-Mounted Liquid Level Switch is designed and engineered for trouble-free operation over a wide range of operating conditions. Common problems are discussed in terms of their symptoms and recommended corrective actions.

3.3.1 External Causes

An initial indication of improper operation is the failure of the controlled equipment to function (pumps will not start or stop, signal lamps fail to light, etc). If these symptoms occur, whether at the time of installation or during routine service thereafter, check for potential external causes first:

- Blown Fuses
- Tripped Reset Button(s)
- Open Power Switch
- Faulty Equipment Controlled By the Level Switch
- Defective Wiring to the Level Switch

3.3.2 Unit Causes

If a thorough inspection of any external causes fails to locate the problem, proceed to an inspection of the unit, itself. **DISCONNECT POWER TO THE LEVEL SWITCH BEFORE PROCEEDING.**

SYMPTOM	PROBLEM	SOLUTION
THE UNIT IS UNRESPONSIVE.	ELECTRICAL FAILURE.	USE AN ELECTRICAL CONTINUITY CHECKER TO DETERMINE IF THE SWITCH IS FUNCTIONAL. IF THE SWITCH DOES NOT OPERATE PROPERLY WHEN ACTIVATED, THE ENTIRE LEVEL SWITCH MUST BE REPLACED.
THE UNIT DOES NOT ACTIVATE WHEN THE FLOAT CHANGES POSITION.	THE UNIT IS JAMMED.	REMOVE THE LEVEL SWITCH FROM SERVICE. CHECK THE FLOAT ASSEMBLY FOR OBSTRUCTIONS OR ACCUMULATION OF PARTICLES WHICH MAY CAUSE BINDING. IF BINDING IS PRESENT IN THE FLOAT ASSEMBLY AND CANNOT BE CLEARED BY NORMAL CLEANING PROCEDURES, THE ENTIRE CONTROL MUST BE REPLACED.
THE UNIT ONLY FUNCTIONS WHEN IT IS NOT IN SERVICE.	LIQUID IS NOT ENTERING THE VESSEL.	CHECK TO ENSURE THAT LIQUID IS ENTERING THE TANK OR VESSEL. A CLOSED VALVE OR CLOGGED PIPELINE MAY PREVENT MOVEMENT OF THE LIQUID IN THE VESSEL.
THE UNIT ONLY FUNCTIONS WHEN IT IS NOT IN SERVICE.	THE TANK LEVEL IS NOT HIGH ENOUGH TO HAVE THE FLOAT FUNCTION.	CHECK THE FLOAT TO MAKE SURE IT IS BUOYANT IN THE LIQUID. THE TANK OR VESSEL MUST HAVE AN ADEQUATE LIQUID LEVEL.
THE FLOAT IS NOT BUOYANT.	THE FLOAT IS COLLAPSED AND/OR FILLED WITH LIQUID.	CHECK THE FLOAT FOR RUPTURES, DEFORMATION, AND ANY LIQUID TRAPPED INSIDE THE ASSEMBLY. IF THE FLOAT IS FILLED WITH LIQUID OR HAS COLLAPSED, THE ENTIRE LEVEL SWITCH MUST BE REPLACED. DO NOT ATTEMPT TO REPAIR THE FLOAT.
ALL COMPONENTS WITHIN THE LEVEL SWITCH ARE IN WORKING ORDER, BUT THE UNIT STILL DOES NOT FUNCTION.	AN EXTERNAL PROBLEM.	REPEAT AN INSPECTION OF THE EXTERNAL CONDITIONS AS DESCRIBED IN SECTION 3.3.1.

 *If you are still in doubt about the condition or performance of your control, consult the factory for further instructions.*

3.4 AGENCY APPROVALS

AGENCY	APPROVED MODEL(S)	FILE NUMBER	AREA CLASSIFICATION
UL 	L001, L002, L003, L170, L175, L176, L177, L178, L180, L190 & L195	E203716	RECOGNIZED UNDER UL508 MOTOR CONTROLLERS & NJ0T8 MOTOR CONTROLLERS

3.5 SPECIFICATIONS

3.5.1 Physical Specifications

MODEL	PROCESS TEMP.	MAX. PRESSURE	FLOAT SPECIFIC GRAVITY	RECOMMENDED MINIMUM LIQUID S.G.	STEM MATERIAL	FLOAT MATERIAL
L001	-40° to +150° F	150 PSIG	0.65	0.95	Polypropylene	Polypropylene
L002	-40° to +150° F	150 PSIG	0.63	0.84	Polypropylene	Polypropylene
L003	-40° to +150° F	150 PSIG	0.65	0.87	Polypropylene	Polypropylene
	-40° to +150° F	50 PSIG	0.49	0.66	Polypropylene	Polypropylene
	-40° to +150° F	50 PSIG	0.74	1.00	PVC	PVC
L170	-40° to +180° F (In Water)	150 PSIG	0.47	0.63	Nylon	Buna
	-40° to +225° F (In Oil)	150 PSIG	0.47	0.63	Brass	Buna
	-40° to +180° F	150 PSIG	0.47	0.63	Brass	Buna
L175	-40° to +300° F	100 PSIG	0.52	0.69	Stainless Steel	Stainless Steel
	-40° to +300° F	100 PSIG	0.52	0.69	Brass	Stainless Steel
L176	-40° to +300° F	300 PSIG	0.74	1.00	Stainless Steel	Stainless Steel
	-40° to +300° F	300 PSIG	0.74	1.00	Brass	Stainless Steel
L177	-40° to +300° F	600 PSIG	0.72	0.96	Stainless Steel	Stainless Steel
	-40° to +300° F	600 PSIG	0.72	0.96	Brass	Stainless Steel
L178	-40° to +300° F	275 PSIG	0.65	0.86	Stainless Steel	Stainless Steel
	-40° to +300° F	275 PSIG	0.65	0.86	Brass	Stainless Steel
L180	-40° to +180° F	150 PSIG	0.48	0.64	Stainless Steel	Buna
	-40° to +180° F	150 PSIG	0.48	0.64	Brass	Buna
L190	-40° to +180° F	150 PSIG	0.43	0.57	Stainless Steel	Buna
	-40° to +180° F	150 PSIG	0.43	0.57	Brass	Buna
	-40° to +300° F	120 PSIG	0.60	0.80	Stainless Steel	Stainless Steel
	-40° to +140° F	150 PSIG	0.43	0.57	PVC	Buna
L195	-40° to +300° F	750 PSIG	0.59	0.79	Stainless Steel	Stainless Steel

3.5.2 Electrical Specifications

SIGNAL OUTPUT	Switch Closure
TYPE OF CONTACTS	SPST, SPDT
TYPE OF SWITCHES	Hermetically-Sealed, Dry Contact Reed Switch
SWITCH RATING	50 VA, 240 VAC/VDC Max.
	100 VA, 240 VAC/VDC Max.
	3 VA, 30 VAC/VDC Max.

3.5.3 Dimensional Specifications

MODEL	THREAD SIZE	HEX	LENGTH	HEIGHT	DIAMETER	STYLE
L001	1/8" NPT	1/2"	1.13"	0.63"	0.63"	2
	3/8" - 16	1/2"	1.13"	0.63"	0.63"	2
L002	1/8" NPT	1/2"	1.53"	1.00"	0.75"	2
	3/8" - 16	1/2"	1.53"	1.00"	0.75"	2
L003	1/8" NPT	1/2"	1.57"	1.00"	1.00"	2
	3/8" - 24	1/2"	1.57"	1.00"	1.00"	2
L170	1/8" NPT	1/2"	1.50"	1.00"	1.00"	2
L175	1/8" NPT	1/2"	1.50"	1.00"	1.50"	2
L176	1/8" NPT	1/2"	1.50"	1.00"	1.06"	2
L177	1/8" NPT	1/2"	1.50"	1.00"	1.18"	1
L178	1/8" NPT	1/2"	1.65"	1.25"	1.03"	2
L180	1/8" NPT	1/2"	2.50"	1.75"	1.19"	2
L190	1/4" NPT	5/8"	2.53"	1.81"	1.88"	2
L195	1/4" NPT	5/8"	2.53"	1.62"	2.06"	1

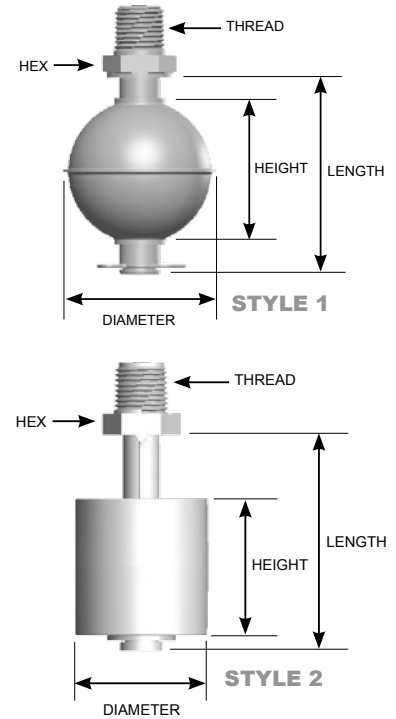

3.6 NOTES

3.7 MODEL CONFIGURATOR

TECHNOLOGY	MODEL	CONFIGURATION	MOUNTING	STEM/BODY	FLOAT	ELECTRICAL	
L Liquid Level Sensor	001	Sub-Compact Switch	- Standard	01 1/8" NPT	01 Brass	02 Polypro (Hollow)	03 50 VA SPST
	002	Sub-Compact Switch	C Custom	02 1/4" NPT	02 Polypropylene	03 Polypro (Solid)	04 100 VA SPST
	003	Compact Switch for High Volume Use		17 3/8" - 16	04 PVDF	04 PVDF	06 3 VA SPDT
	170	Compact Switch for High Temperatures & Pressures		18 3/8" - 24	05 PVC	05 PVC (Hollow)	
	175	Compact Switch for High Temperatures & Pressures			08 316/316L S.S.	08 316/316L S.S.	
	176	Compact Switch for High Temperatures & Pressures			18 Nylon	20 Buna-N	
	177	Compact Switch for High Temperatures & Pressures					
	178	Compact Switch for High Temperatures & Pressures					
	180	Large Switch					
	190	Intermediate Switch for High-Viscosity Liquids					
	195	All Stainless Steel Spherical Switch					

3.8 REPLACEMENT PARTS

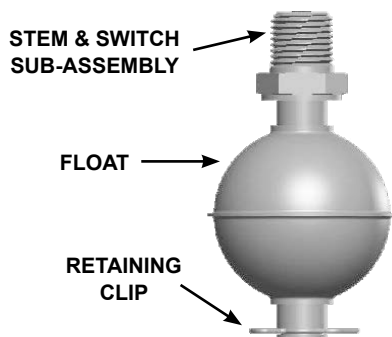

When Ordering, Please Specify:

- Model & Serial Numbers
- Name & Part Number of Replacement Part or Assembly

All replacement parts are for standard models *only*. Contact the manufacturer for ordering assistance on all specially modified models (model numbers followed by a "C"; i.e. L003C, L177C, etc.)

ASSURED QUALITY & SERVICE COST LESS

Service Policy

Owners of Solutions With Innovation products may request a return of the product, or any part of the product for complete rebuilding or replacement. Units will be rebuilt or replaced promptly. Products returned under the SWI Service Policy must be returned by prepaid transportation. Solutions With Innovation will repair or replace the product at no cost to the purchaser (or owner) other than transportation if:

- 1 Returned within the warranty period; and
- 2 Factory Inspection finds the cause of the claim to be covered under the warranty.

If the problem is due to circumstances beyond Solutions With Innovation's liability, or is NOT covered by the warranty, there will be charges for labor in addition to the parts required to rebuild or replace the equipment.

In rare cases, it may be expedient to ship replacement parts; or in extreme cases, an entire product before the damaged product is returned. If a quick replacement service is necessary, notify the manufacturer of the damaged product's model and serial number. In such cases, credit for the returned materials will be determined on the applicability of the warranty.

No claims for misapplication, labor, direct or consequential damage will be allowed.

Return Material Procedure

In order to efficiently process any returned materials, it is essential that a *Return Material Authorization* (RMA) number be obtained from the manufacturer prior to an item's return. RMAs can be issued through local representatives, or by contacting the factory directly.

Please supply the following information:

- 1 The Company's Name
- 2 Description of the Material
- 3 Product Serial Number
- 4 Reason for Return
- 5 Product's Application

Used units must be properly cleaned in accordance with OSHA standards before it is returned to the manufacturer. A *Material Safety Data Sheet* (MSDS) must accompany units or materials that were used in any type of media. All return shipments to the factory must be by done via prepaid transportation. All product replacements will be shipped F.O.B. manufacturer.

BULLETIN: IS-9110.2
EFFECTIVE: 1/15

