

PSOX POSITION SWITCH

INSTALLATION AND OPERATIONS MANUAL

Position Switch For Commercial Use



PS01

PS02





This manual provides information on the **PS0X Position Switch for Commercial Use**. It is important that all instructions are read carefully and followed sequentially. Detailed instructions are included in the **Complete Installation** section of this manual.

Conventions Used in this Manual

Certain conventions are used in this manual to convey specific types of information. General technical material, support data and safety information are presented in narrative form. The following styles are used for notes, cautions and warnings:

Notes

Notes contain information that augments or clarifies an operating step. Notes do not normally contain actions and often follow the procedural steps to which they refer.

Cautions

Cautions alert the technician to special conditions that could injure personnel, damage equipment, or reduce a component's mechanical integrity. Cautions are also used to alert the technician of unsafe practices, the need for special protective equipment, or specific materials. In this manual, a caution indicates a potentially hazardous situation which, if not avoided, may result in minor to moderate injury.

Warnings

Warnings identify potentially dangerous situations, or serious hazards. In this manual, a warning indicates an imminently hazardous situation which, if not avoided, may result in serious injury or death.

Safety Messages

Follow all standard industry procedures for servicing electrical and computer equipment when working with, or around high voltage. Always shut off the power supply before touching any components. Although high voltage is not present in this system, it may be present in other systems.

If the equipment is used in a manner not specified by the manufacturer, protection provided by equipment may be impaired.

Notice of Copyright and Limitations

Copyright ©2022 AMETEK Magnetrol USA, LLC
All rights reserved.

Solutions With Innovation reserves the right to make changes to the product described in this manual at any time without notice. Solutions With Innovation makes no warranty with respect to the accuracy of the information in this manual.

Warranty

All Solutions With Innovation Level, Position and Flow Controls are warranted free of defects in materials and workmanship for one full year from the date of the original factory shipment. If returned within the warranty period; and, upon factory inspection of the control, the cause of the claim is determined to be covered under the warranty; then, Solutions With Innovation will repair or replace the product at no cost to the purchaser (or owner) other than transportation.

Solutions With Innovation shall not be liable for misapplication, labor claims, direct or consequential damage, or expenses arising from the installation or use of the equipment. There are no other warranties expressed or implied, except special written warranties covering specific Solutions With Innovation products.

Quality Assurance

The Quality Assurance System in place at Solutions With Innovation guarantees the highest level of quality throughout the company. Solutions With Innovation is committed to providing full customer satisfaction; both in quality products and in quality service.

Contacts

Phone: 203-729-6434 *Mon-Fri, 9 AM - 5 PM EST* Fax:
203-729-0541 *for General Inquiries*
Email: ct-nau-info@ametek.com

PSOX POSITION SWITCH

For Commercial Use

TABLE OF CONTENTS

1.0 Installation

- 1.1 Unpacking.....4
- 1.2 Before You Begin.....4
 - 1.2.1 Site Preparation.....4
 - 1.2.2 Equipment and Tools.....4
- 1.3 Mounting.....5
 - 1.3.1 Flanged Mounting.....5
- 1.4 Wiring.....5

2.0 Preventative Maintenance

- 2.1 What To Do.....6
 - 2.1.1 Inspect Entire Unit Periodically.....6
 - 2.1.2 Inspect Connections Monthly.....6
 - 2.1.3 Keep Unit Clean.....6
- 2.2 What To Avoid.....6

3.0 Reference Information

- 3.1 Description.....7
- 3.2 Theory of Operation.....7
- 3.3 Troubleshooting.....8
 - 3.3.1 External Causes.....8
 - 3.3.2 PSOX Causes.....8
- 3.4 Agency Approvals.....9
- 3.5 Specifications.....9
 - 3.5.1 Functional Specifications.....9
 - 3.5.2 Dimensional Specifications.....10
- 3.6 Model Configurator.....10
- 3.7 Notes.....11

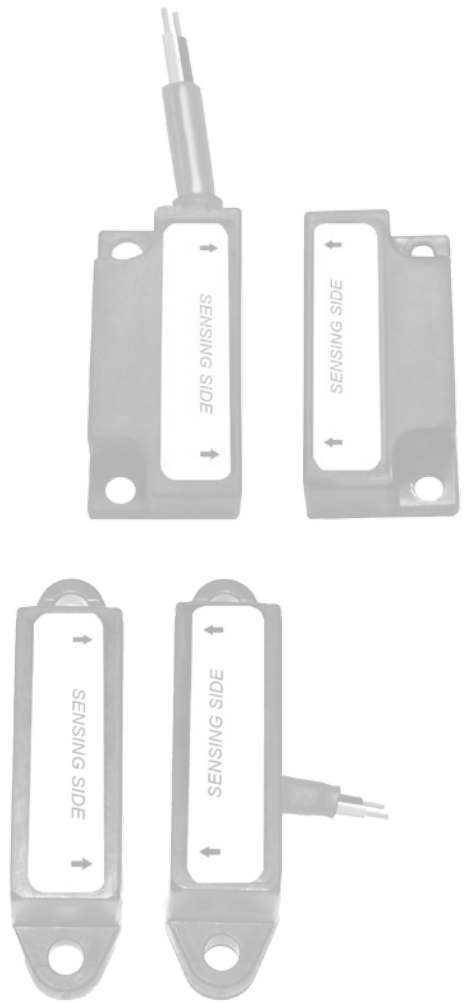

1.0 COMPLETE INSTALLATION

This section provides detailed procedures on properly installing the Model PS0X Position Switch.

 **CAUTION!** IF THE EQUIPMENT IS USED IN A MANNER NOT SPECIFIED BY THE MANUFACTURER, PROTECTION PROVIDED BY THE EQUIPMENT MAY BE IMPAIRED.

1.1 UNPACKING

Unpack the instrument, carefully. Make sure that all components have been removed from the packing material. Inspect all components for damage. Report any concealed damage to the carrier within 24 hours of receiving. Compare the contents with the packing slip and report any discrepancies to the factory immediately. Record the sales order number and/or the serial number for future reference when ordering parts.

Before Proceeding to Installation, Complete the Following:

- Inspect all components for damage. Report any damage to the carrier within 24 hours of receiving.
- Record the model and serial numbers for future reference when ordering parts.

Model Number _____

Serial Number _____

1.2 BEFORE YOU BEGIN

1.2.1 Site Preparation

Verify that the designated mounting area for the Model PS0X Position Switch is clean and free of any particulate matter. Refer to **Section 1.3: Mounting**.

Ensure that all wires are mounted properly to prevent kinks and pinching between components. When installing the Model PS0X Position Switch, all applicable electrical codes and wiring procedures must be observed. Refer to **Section 1.4: Wiring**.

1.2.2 Equipment and Tools

No special equipment or tools are required to install the Model PS0X Position Switch.

The Following Are Recommended:

- (4) #10 Mounting Screws
- Screwdriver for Mounting Screws

1.3 MOUNTING

The Model PS0X Position Switch is equipped with mounting holes for quick installation and easy attachment to the end user's intended application. The amount of screws necessary for installation correlates to the type of magnet housing.

1.3.1 Flanged Mounting

Each of the PS0X products utilize a flange-type mounting attachment for quick installation.

How to Install a Model PS0X Position Switch:

- 1 Mark the intended position of the switch on the equipment. Be sure to also mark the location of the mounting hole for easy alignment.
- 2 Secure the switch into place by inserting the screws through the mounting holes and then tighten.

CAUTION! DO NOT OVERTIGHTEN THE SCREWS AS DAMAGE CAN OCCUR TO THE MOUNTING HOLES OR TO THE SWITCH ITSELF.

- 3 Route the cable to prevent any possible damage.
- 4 Test the equipment to ensure proper functioning.

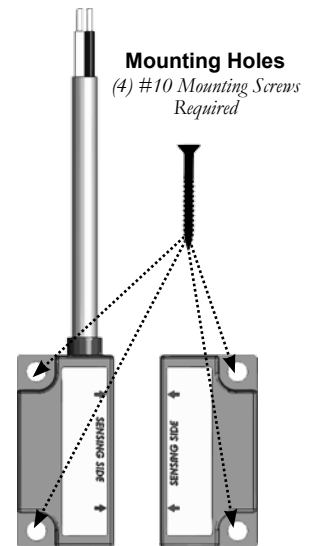

1.4 WIRING

CAUTION! OBSERVE ALL APPLICABLE ELECTRICAL CODES AND PROPER WIRING PROCEDURES.

NOTE: A SWITCH OR CIRCUIT BREAKER SHOULD BE INSTALLED IN CLOSE PROXIMITY TO THE EQUIPMENT WHERE IT IS ALSO EASILY ACCESSIBLE TO THE OPERATOR. THE UNIT SHOULD BE MARKED AS THE DISCONNECTING DEVICE FOR THE EQUIPMENT.

SPST Reed Switch:

- 1 Connect the wiring to the proper switch leads.
- 2 When the magnet is out of the *actuation range*, a *normally open* (N.O.) state will result.

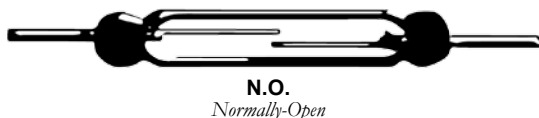

SPDT Reed Switch:

- 1 Connect the wiring to the proper switch leads.
- 2 When the magnet is out of the *actuation range*, a *normally closed* (N.C.) state will result.

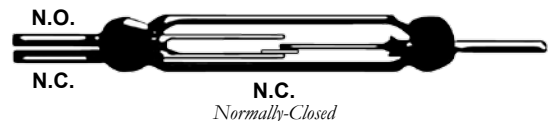

NOTE: FOR INSTALLATIONS WITH AMBIENT TEMPERATURES UP TO 70°C, USE WIRES WITH A **MINIMUM** RATING OF 75° C, AS REQUIRED BY THE PROCESS CONDITIONS. FOR INSTALLATIONS WITH AMBIENT TEMPERATURES UP TO 80°C, USE WIRES WITH A **MINIMUM** RATING OF 85° C, AS REQUIRED BY THE PROCESS CONDITIONS.

2.0 PREVENTATIVE MAINTENANCE

Periodic inspections are necessary to maintain the proper functionality of the Model PS0X Position Switch. The switch is a safety device that protects the equipment it serves. A systematic program of preventative maintenance should be implemented at the time of installation. If the following instructions are completed routinely, the switch will provide continuous, reliable protection.

2.1 MAINTENANCE PROCEDURES

2.1.1 Inspect Unit Periodically

Verify that there are no cracks or chipped surfaces on the switch's housing. Should the enclosure become damaged, obtain a replacement immediately.

2.1.2 Inspect Connections Monthly

Model PS0X Position Switches may be vulnerable to excessive heat and moisture. Under these conditions, the electrical wire insulation can periodically break or peel away. As a result, the bare wires may become exposed to the elements and cause damage.

- Inspect all wiring, carefully and replace any wires exhibiting signs of brittle insulation.
- Inspect all electrical connections to ensure tightness.
- Repair or replace any wiring, if necessary.



2.1.3 Keep Unit Clean

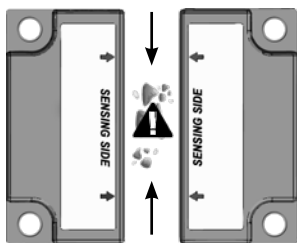

Periodic cleanings of the switch and magnet housings will ensure the continual, uninterrupted operation of the switching system.

It is important to always keep the open area between the enclosures clean and free of any potential interferences. Objects and debris may cause systematic interruptions and a loss in equipment functionality.

2.2 WHAT TO AVOID

- ⚠ **NEVER LEAVE ANY MOUNTING SCREWS LOOSE.** *Performance will decrease or cease to operate.*
- ⚠ **NEVER PLACE UNINTENDED MAGNETIC OR METALLIC COMPONENTS NEAR THE POSITION SWITCH.**
- ⚠ **NEVER OVERPOWER THE POSITION SWITCH AND ALWAYS VERIFY THAT THE RATING IS NOT EXCEEDED.** *In some cases, the user may need to add circuit suppression to eliminate voltage spikes caused by components such as contactors or solenoids.*

3.0 REFERENCE INFORMATION

This section illustrates an overview of the Model PS0X Position Switch, as well as information on troubleshooting common problems, agency approval listings, and detailed physical, functional and performance specifications.

3.1 DESCRIPTION

The Models PS01 and PS02 Position Switches are magnet-actuated devices designed for use in the typical applications of safety interlocks, position indication, equipment automation, door interlocks and other general purposes. Both models are equipped with flanged-type mounting attachments for easy installation.

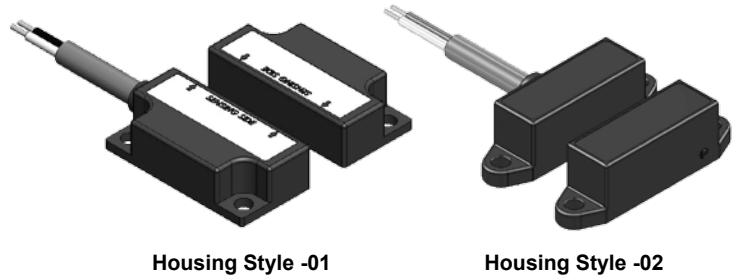

3.2 THEORY OF OPERATION

Two main elements are attributed to the operation of the PS0X Position Switch:

- The *Switch Housing*
- The *Magnet Housing*

SPST Relay

The operation of the reed switch is based on the principle of *magnetic induction*. When a magnet, permanent or electromagnetic is in proximity to an object comprised of soft iron, the object magnetizes.

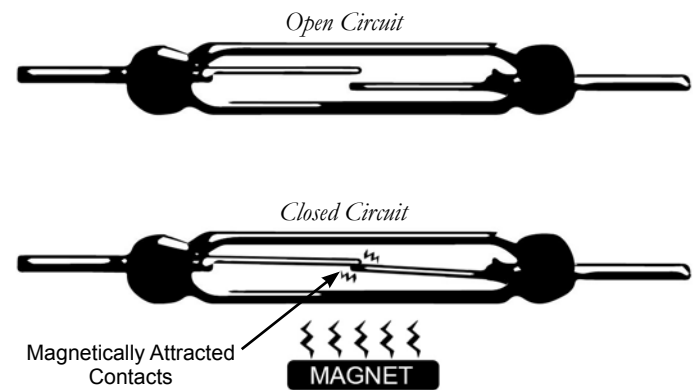

If a strong magnetic field moves adjacent to the reed switch, the contacts become induced magnets and attract each other. As a result, the contacts close and create a continuous electrical path through the switch. When the magnetic field is removed, the contacts reopen. In processes requiring higher current and power, the reed switch can be used to control a solenoid relay of the necessary rating. The limitations to this process are dependent upon the strength of the magnet and the overall reluctance of the magnetic circuit.

TRIAC Circuit

When a magnet approaches a proximity switch, the reed switch inside the housing closes. As a result, the closure creates a continuous electrical path through the TRIAC, supporting the connected load. When the magnetic field is removed, the contacts reopen and discontinue the electrical path to the TRIAC.

3.3 TROUBLESHOOTING

The Model PS0X Position Switch is designed and engineered for trouble-free operation over a wide range of operating conditions. Common problems are discussed in terms of their symptoms and recommended corrective actions.

3.3.1 External Causes

An initial indication of improper operation is the failure of the controlled equipment to function (pumps will not start or stop, signal lamps fail to light, etc). If these symptoms occur, whether at the time of installation or during routine service thereafter, check for potential external causes first:

- Blown Fuses
- Tripped Reset Button(s)
- Open Power Switch
- Faulty Equipment Controlled By the Position Switch
- Defective Wiring to the Position Switch

3.3.2 PS0X Causes

If a thorough inspection of any external causes fails to locate the problem, proceed to an inspection of the unit, itself. **DISCONNECT POWER TO THE LEVEL SWITCH BEFORE PROCEEDING.**

SYMPTOM	PROBLEM	SOLUTION
THE UNIT IS UNRESPONSIVE.	ELECTRICAL FAILURE.	USE AN ELECTRICAL CONTINUITY CHECKER TO DETERMINE IF THE SWITCH IS FUNCTIONAL. IF THE SWITCH DOES NOT OPERATE PROPERLY WHEN MAGNETICALLY ACTUATED, THE ENTIRE POSITION SWITCH MUST BE REPLACED.
THE UNIT IS UNRESPONSIVE.	DEFECTIVE MAGNET HOUSING.	IF THE SWITCH FUNCTIONS MAGNETICALLY, BUT DOES NOT ACTIVATE WHEN THE ACCOMPANYING MAGNET HOUSING CHANGES POSITION, REPLACE THE MAGNET ASSEMBLY WITH A NEW ONE.
ALL COMPONENTS WITHIN THE LEVEL SWITCH ARE IN WORKING ORDER, BUT THE UNIT STILL DOES NOT FUNCTION.	AN EXTERNAL CAUSE IS CONTRIBUTING TO THE PROBLEM.	REPEAT AN INSPECTION OF THE EXTERNAL CONDITIONS AS DESCRIBED IN SECTION 3.3.1 .

 *If you are still in doubt about the condition or performance of your control, consult the factory for further instructions.*

3.4 AGENCY APPROVALS

AGENCY	APPROVED MODEL(S)	FILE NUMBER	AREA CLASSIFICATION
UL 	PS0X-YYXX-QQWW	E337008	GENERAL USE

3.5 SPECIFICATIONS

3.5.1 Functional Specifications

INPUT	
MEASURED VARIABLE:	Position Change
OUTPUT	
SIGNAL:	Switch Closure
PHYSICAL RANGE:	Refer to Section 3.5.2
TYPE OF CONTACTS:	SPST, SPDT
TYPE OF SWITCHES:	Hermetically-Sealed Reed Switch or TRIAC Version
SWITCH RATINGS:	SPST 50 VA. Max., 240 VAC/VDC Max., 0.5 Amp Max.
	SPST 100 VA. Max., 240 VAC/VDC Max., 1 Amp Max.
	SPDT 100 VA. Max., 240 VAC/VDC Max., 3 Amp Max.
	TRIAC, 240 VAC/VDC Max., 1.25 Amp Max.
ENVIRONMENTAL	
OPERATING TEMPERATURE:	-20° to +140° F (-29° to +60° C)
AMBIENT TEMPERATURE:	-20° to +140° F (-29° to +60° C)
MATERIALS	
SWITCH HOUSING:	Kynar, Nylon or Noryl
MAGNET HOUSING:	Kynar, Nylon or Noryl
MAGNET:	Neodymium or Alnico
HOUSING MOUNTING:	Provisions for (4) #10 Screws
CONNECTION:	20 AWG Minimum, 2 Conductor Cable SJTOW, 300 Volt

3.5.2 Physical Specifications

HOUSING STYLE - PS01		
MAGNET TYPE:	Neodymium	Alnico
SENSING RANGE:	1 $\frac{3}{16}$ " Nom.	1" Nom.
BREAK RANGE:	1 $\frac{1}{2}$ " Nom.	1 $\frac{1}{4}$ " Nom.
HOUSING STYLE - PS02		
MAGNET TYPE:	Neodymium	Alnico
SENSING RANGE:	1 $\frac{3}{16}$ " Nom.	1" Nom.
BREAK RANGE:	1 $\frac{1}{2}$ " Nom.	1 $\frac{1}{4}$ " Nom.

3.5.3 Dimensional Specifications

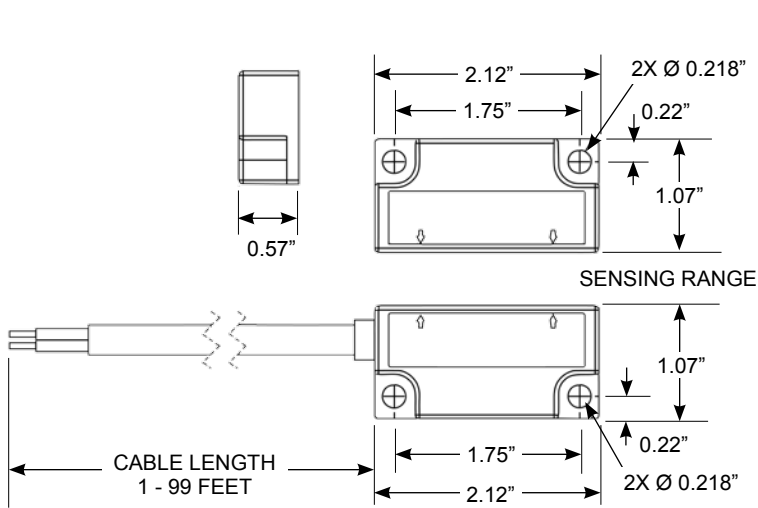

HOUSING STYLE -01

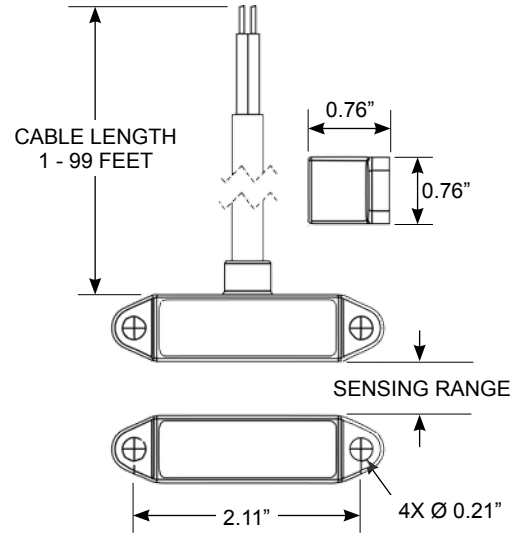

HOUSING STYLE -02

3.6 MODEL CONFIGURATOR

TECHNOLOGY		HOUSING STYLE		SWITCH TYPE		HOUSING		MAGNET		CABLE LENGTH	
PS	Position Switch	01	Straight Cable Egress	00	No Switch (Magnet Holder Only)	04	Kynar	00	No Magnet	00	No Cable
		02	T-Cable Egress	03	50 VA, 0.5 Amp, 240 VAC/DC Max.	18	Nylon	NE	Neodymium	WW	01 to 99 Feet
		03	Long Magnet Holder (3.92")	04	100 VA, 1 Amp, 240 VAC/DC Max.	24	Noryl	AL	Alnico		
		04	No Switch (Holder Only) Style 02	15	100 W, 3 Amp, 240 VAC/DC Max (NO)						
		00	No Switch (Holder Only) Style 01	16	100 W, 3 Amp, 240 VAC/DC Max (NC)						
				TR	TRIAC, 1.25 Amp, 240 VAC/DC Max.						

P
S
0
1

-

0
4
0
4

-

N
E
1
0

3.7 NOTES

ASSURED QUALITY & SERVICE COST LESS

Service Policy

Owners of Solutions With Innovation products may request a return of the product, or any part of the product for complete rebuilding or replacement. Units will be rebuilt or replaced promptly. Products returned under the SWI Service Policy must be returned by prepaid transportation. Solutions With Innovation will repair or replace the product at no cost to the purchaser (or owner) other than transportation if:

- 1 Returned within the warranty period; and
- 2 Factory Inspection finds the cause of the claim to be covered under the warranty.

If the problem is due to circumstances beyond Solutions With Innovation's liability, or is NOT covered by the warranty, there will be charges for labor in addition to the parts required to rebuild or replace the equipment.

In rare cases, it may be expedient to ship replacement parts; or in extreme cases, an entire product before the damaged product is returned. If a quick replacement service is necessary, notify the manufacturer of the damaged product's model and serial number. In such cases, credit for the returned materials will be determined on the applicability of the warranty.

No claims for misapplication, labor, direct or consequential damage will be allowed.

Return Material Procedure

In order to efficiently process any returned materials, it is essential that a *Return Material Authorization* (RMA) number be obtained from the manufacturer prior to an item's return. RMA's can be issued through local representatives, or by contacting the factory directly.

Please supply the following information:

- 1 The Company's Name
- 2 Description of the Material
- 3 Product Serial Number
- 4 Reason for Return
- 5 Product's Application

Used units must be properly cleaned in accordance with OSHA standards before it is returned to the manufacturer. A *Material Safety Data Sheet* (MSDS) must accompany units or materials that were used in any type of media. All return shipments to the factory must be by done via prepaid transportation. All product replacements will be shipped F.O.B. manufacturer.

BULLETIN: IS-9988.3
EFFECTIVE: 1/15

