



MAGNETROL[®]

AMETEK[®]

LEVEL MEASUREMENT
SOLUTIONS

F10 & F50 Flow Switches

DESCRIPTION

AMETEK LMS flow switches are highly reliable devices utilized to sense the start or stop of flow in horizontal pipelines containing oil and petroleum derivatives, chemicals, water, or air.

Vane-actuated Model F10 switches are used on gas or liquid flow applications in 2" or larger line sizes.

Disc actuated Model F50 switches are in-line type used for sensing clean liquids in 2" or smaller line sizes.

FEATURES

- Actuation on increasing or decreasing flow
- Special sensing elements for non-standard or high flow applications
- Designed for horizontal pipe applications
- Available switch styles include dry contact, hermetically sealed and pneumatic

Model F10

- Field adjustable
- Low pressure drop
- Process pressures to 1000 psig (69 bar)
- Process temperatures to +450 °F (+232 °C)
- Standard flow vanes for 2" thru 10" flow lines

Model F50

- No calibration required
- Bronze or stainless steel construction
- Process pressures to 1150 psig (79.2 bar)
- Process temperatures to +750 °F (+399 °C)
- Bodies for flow lines from ¾" to 2"



Model F10

Model F50

APPLICATIONS

- Pump staging or failure
- Pipeline flow detection
- Valve failure
- Loss of pipeline flow
- Pipe blockage/rupture
- Pump inlet flow protection
- Check valve blockage/leakage
- Alarm on eyewash or shower safety station

TECHNOLOGY

MODEL F10

Flow through the horizontal pipeline causes the pivoted vane assembly to swing in the direction of the flow. The vane assembly lifts an attraction sleeve which in turn causes the magnet to pull in and actuate the switch.

The O-ring sealed adjusting screw in the top of the enclosing tube compresses the range spring located

above the attraction sleeve. Turning the adjusting screw clockwise increases the flow rate at which the switch actuates. Adjustments can be made while the flow switch is in service.

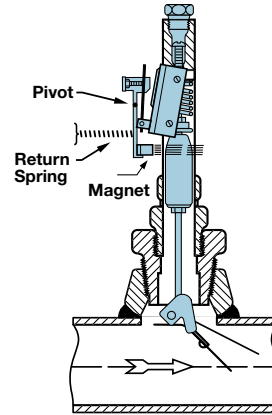
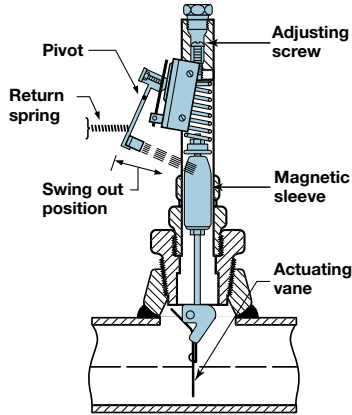

Model F50

The rate of flow through the valve body raises or lowers the disc. This in turn raises or lowers the magnetic sleeve within its sealed non-magnetic enclosing tube. On an increasing flow rate, the magnetic sleeve rises into the field of the permanent magnet, located outside

the enclosing tube, actuating the attached switch mechanism. When the flow rate drops below the rate for which the flow disc is calibrated, a reversal of this action occurs.

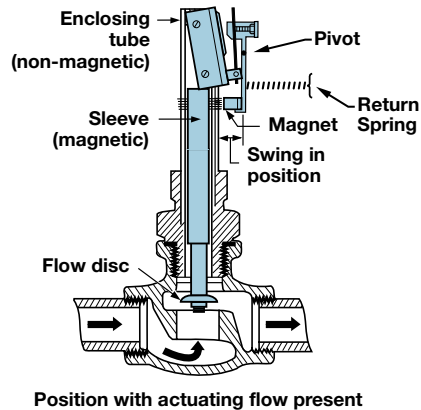
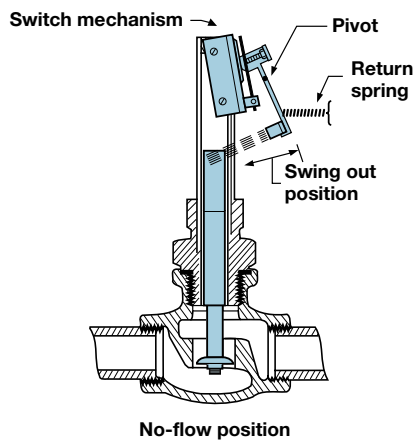

TYPICAL APPLICATIONS

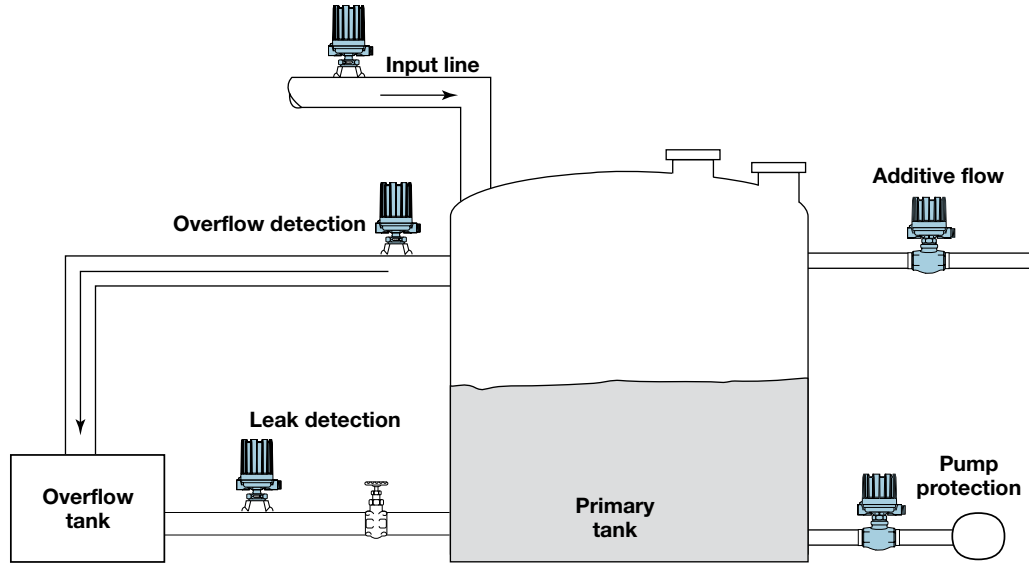

MODEL F50 PRESSURE DROP ACROSS SWITCH

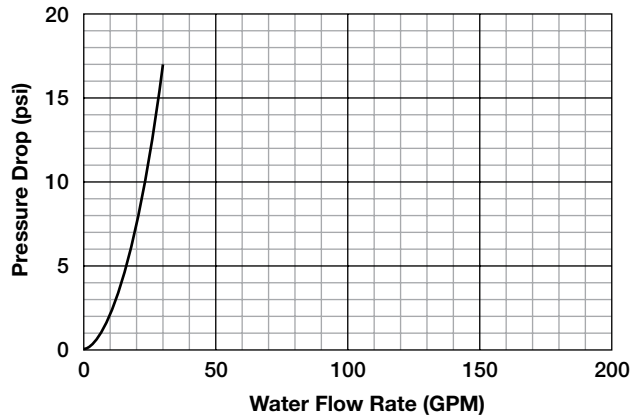

Model F50 with 3/4" NPT connection

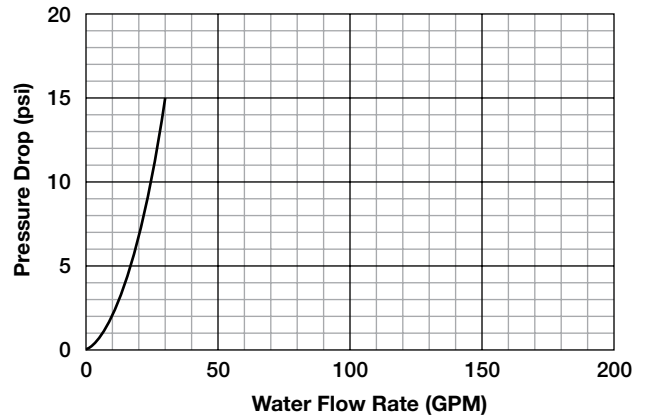

Model F50 with 1" NPT connection

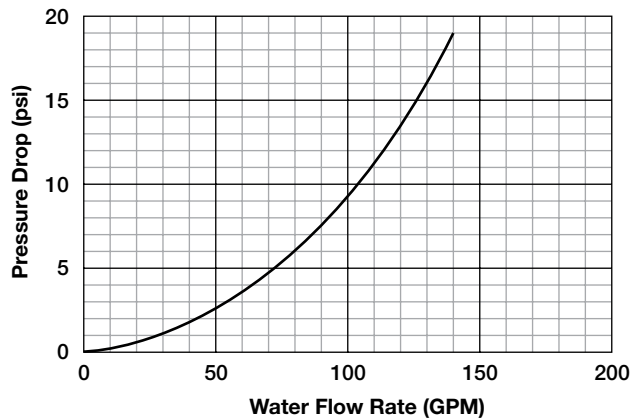

Model F50 with 1 1/2" NPT connection

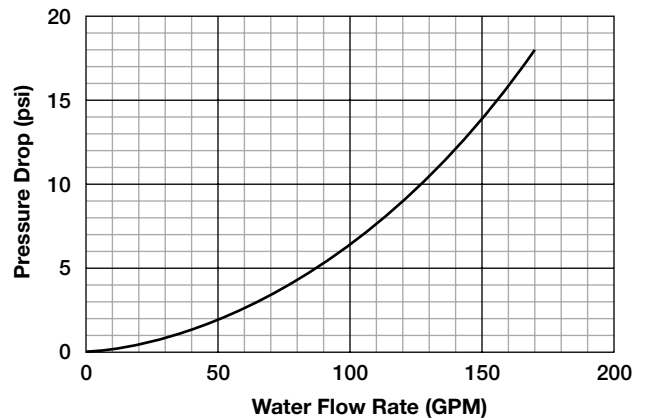

Model F50 with 2" NPT connection

SPECIFICATIONS

SWITCH MECHANISMS AND ENCLOSURES

Switch enclosures

- TYPE 4X/7/9 aluminum enclosures
- Designed to meet Class I, Div. 1, Groups C & D and Class I, Div. 1 Group B
- Optional housing heaters and drains available for some enclosures
- Pneumatic switch mechanisms available with a NEMA 1 enclosure



Series HS & F Hermetically switches

- Ideal for use in salt and other corrosive atmospheres
- Series “HS” is positively pressurized capsules for entire mechanism and contacts
- Process temperatures to +750 °F (+399 °C)



Series B, C & D Dry contact switches

- Dry contact for applications where mercury must be avoided
- Designs for AC and DC current applications
- Process temperatures to +450 °F (+232 °C)



Series J & K Pneumatic switches

- Suited for applications where electrical power is not available
- Bleed and non-bleed designs
- Process temperatures to +400 °F (+204 °C)



BASIC ELECTRICAL RATINGS

Voltage	Switch Series and Non-Inductive Ampere Rating				
	B	C	D	F	HS
120 VAC	15.00	15.00	10.00	2.50	5.00
240 VAC	15.00	15.00	—	—	5.00
24 VDC	6.00	10.00	10.00	4.00	5.00
120 VDC	0.50	1.00	10.00	0.30	0.50
240 VDC	0.25	0.50	3.00	—	0.25

SPECIFIC GRAVITY CORRECTION

To determine the actuating flow rates for liquids other than water (approximate viscosity of 20 centistokes or less), a specific gravity correction factor must be applied to the water flow rates given in the table. For gas/air applications, consult factory.

Model F10 Example:

The maximum adjustment for an increasing flow rate on a Model F10 with a liquid specific gravity of .70 in an 8" line is: 230 GPM × 1.20 = 276 GPM.

Model F50 Example:

The actuation flow rate of a liquid with specific gravity of 1.10 on increasing flow for a Model F50 with a 1" body and an “E” size disc is: 5.5 GPM × 0.95 = 5.2 GPM.

Specific Gravity	Multiplication Factor	Specific Gravity	Multiplication Factor
.40	1.58	.95	1.03
.45	1.49	1.00	1.00
.50	1.41	1.05	.98
.55	1.35	1.10	.95
.60	1.29	1.15	.93
.65	1.24	1.20	.91
.70	1.20	1.25	.89
.75	1.15	1.30	.88
.80	1.12	1.35	.86
.85	1.08	1.40	.85
.90	1.05	1.45	.83

AGENCY APPROVALS



EMC directive 2014/30/EU (electromagnetic compatibility)
 The following standard has been applied:
 EN 61326-1:2013-(Low Voltage Directive-CE)





 T
Y 4X
P
E

705 ENTERPRISE ST AURORA, IL 60504 USA

MODEL NO
 SERIAL NO

INPUT: AMB TEMP: -40°C TO +70°C
 OUTPUT: MAX.PRESS:

Approval: FM Type 4X 005-8047-003
 Housing Material: Carbon Steel/Aluminum



 T
Y 4X
P
E
IP66
SINGLE SEAL

705 ENTERPRISE ST AURORA, IL 60504 USA

MODEL NO
 SERIAL NO

INPUT: AMB TEMP: -40°C TO +70°C
 OUTPUT: MAX.PRESS:

MANUF YEAR:
 FM21US0099X\FM21CA0066X SEAL AT THE ENCLOSURE/
 CL I DIV 1 GPS B,C,D T6...T1 SCELLER A L ENCEINTE
 CL II DIV 1 GPS E,F,G
 CL III SINGLE SEAL

Approval: FM US/CA 005-8049-009
 Housing Material: Aluminum



 IP66
SINGLE SEAL

705 ENTERPRISE ST AURORA, IL 60504 USA

MODEL NO
 SERIAL NO

INPUT: AMB TEMP: -40°C TO +70°C
 OUTPUT: MAX.PRESS:

MANUF YEAR:
 FM21US0099X\FM21CA0066X SEAL AT THE ENCLOSURE/
 CL I DIV 1 GPS B,C,D T6...T1 SCELLER A L ENCEINTE
 CL II DIV 1 GPS E,F,G
 CL III SINGLE SEAL

Approval: FM US/CA 005-8049-072
 Housing Material: Cast Iron

AGENCY APPROVALS

 **MAGNETROL** / **AMETEK**
705 ENTERPRISE ST AURORA, IL 60504 USA
MADE BY: 9240 ZELE BELGIUM



MODEL NO
SERIAL NO

FM21ATEX0060X\FM21UKEX0206X
II 2 G Ex db IIC T6...T1 Gb

IECEX FMG 21.0032X
Ex db IIC T6...T1 Gb

TAG NO
MAX PRESS MIN SG
VAC/A
VDC/A
CABLE ENTRY

AMB TEMP: -40°C TO 70°C
MANUF. YEAR:

IP66  0518   0343
0344



Approval: ATEX/IECEX **005-8060-008**
Housing Material: Aluminum

 **MAGNETROL** / **AMETEK**
705 ENTERPRISE ST AURORA, IL 60504 USA
MADE BY: 9240 ZELE BELGIUM



MODEL NO
SERIAL NO

FM21ATEX0060X\FM21UKEX0206X
II 2 G Ex db IIC T6...T1 Gb

IECEX FMG 21.0032X
Ex db IIC T6...T1 Gb

TAG NO
MAX PRESS MIN SG
VAC/A
VDC/A
CABLE ENTRY

AMB TEMP: -40°C TO 70°C
MANUF. YEAR:

IP66  0518   0343
0344



Approval: ATEX/IECEX **005-8060-021**
Housing Material: Cast Iron

AGENCY APPROVALS

Maximum Pressure Ratings:

These are the ranges of process pressure ranges based on each individual model as mention in each individual manual.

Nominal Thickness (in)	Minimum Thickness (in)	Pressure Rating for 316 SST Version (psig)
0.035	0.0295	1300
0.065	0.0595	2710
0.093	0.087	5000

When the equipment is installed in process temperatures higher than +85°C the temperature classification must be increased according to the following table as per IEC60079-0.

Maximum Process Temperature	Temperature Classification
<85°C	T6
<100°C	T5
<135°C	T4
<200°C	T3
<300°C	T2
<450°C	T1

Additional Approvals:

- Series C, U, W, and X switch mechanisms, along with Tuffy T3X designs, in Aluminum or Cast Iron housings, are certified for Ex ia IIC T6 Ga per Certificate No. IECEx KIWA 18.0011X and ATEX II 1 G Ex ia IIC T6 Ga per Certificate No. KIWA 18ATEX0022 X Issue: 1.
- Series HS, F, 8, and 9 switch mechanisms, in Type 4X housings, are CSA certified for Class I, Div 2, Groups A, B, C & D.

Specific Conditions of Use

1. The flamepaths of the equipment are not intended to be repaired. Consult the manufacturer if repair of the flamepath joints is necessary.
2. Refer to the manufacturer's instructions to reduce the potential of an electrostatic charging hazard on the equipment enclosure.
3. The cast iron enclosure for ATEX, UKEX and IECEx certification does not contain an IP rating.
4. The cast iron enclosure for North American certification does not contain a Type 4X rating.
5. For installation with ambient temperature of 70°C, refer to the manufacturer's instruction for guidance on proper selection of conductors.

F10 DIMENSIONAL SPECIFICATIONS

INCHES (MM)

Note: Model F10 is intended for use in horizontal pipelines only. For proper performance, a straight pipe run of 12 pipe diameters upstream and 3 pipe diameters downstream of the switch is recommended.

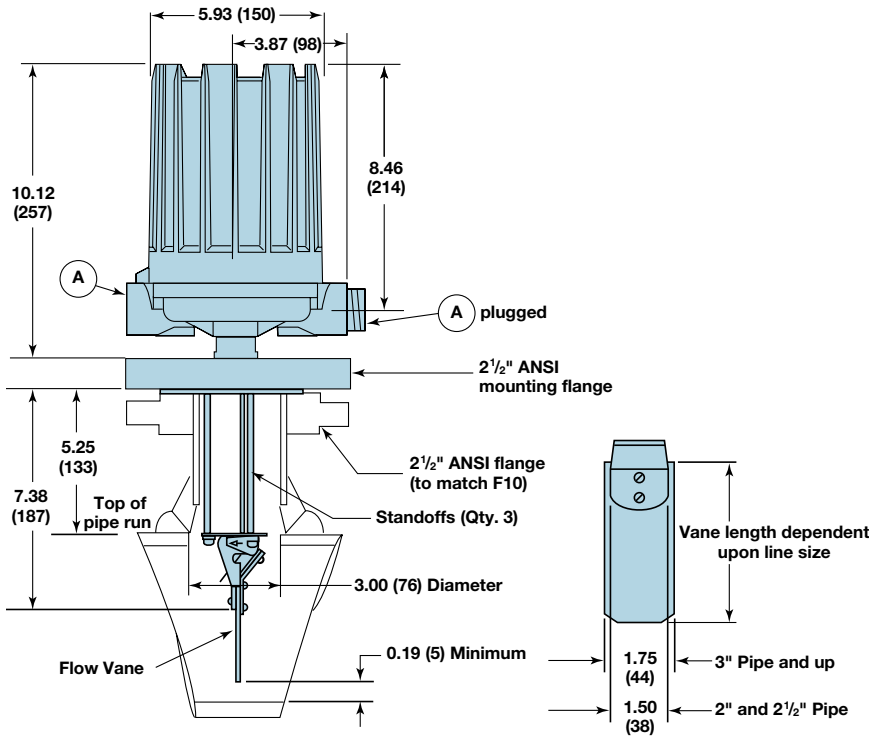

F10 with flanged connection

Conduit Connections A
Electrical Switches: 1" NPT
Pneumatic Switches: ¼" NPT

All housings rotatable 360°

Note: Allow the following for overhead clearance for cover removal:

- Carbon Steel (pneumatic)8.00 (203)
- Aluminum10.00 (254)

Line Size	Dim. B Max.	Equivalent Max. Wall Schedule
2"	1.81 (46)	80
2½"	1.94 (49)	160
3"	1.88 (48)	80
3½"	1.88 (48)	80
4"	2.00 (51)	120
5"	2.06 (52)	120
6"	2.12 (54)	120
8"	2.19 (56)	100
Over 8"	2.31 (59)	—

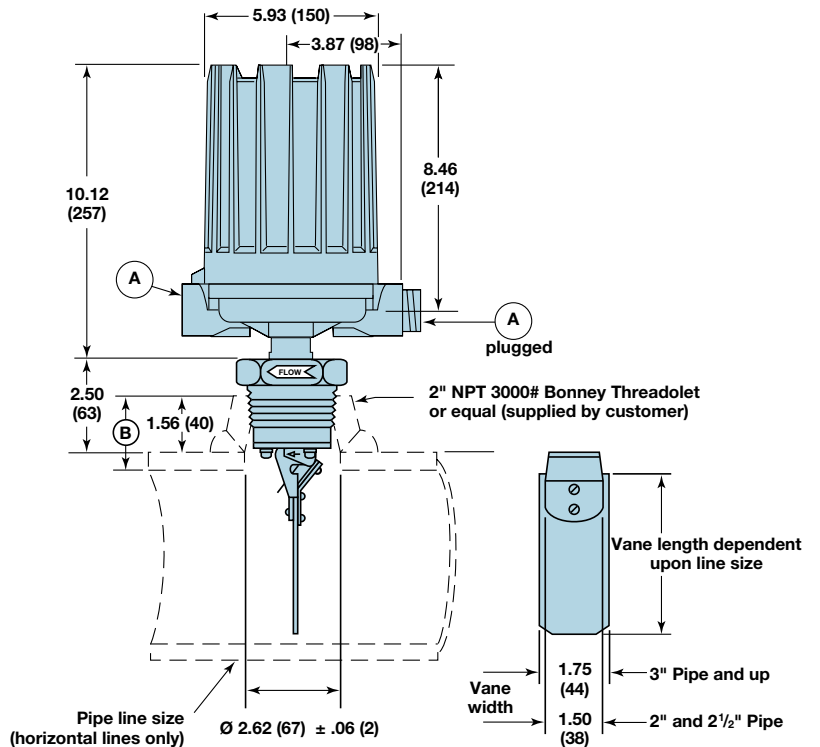

F10 with 2" NPT connection

F50 DIMENSIONAL SPECIFICATIONS

INCHES (MM)

Note: Model F50 is intended for use in horizontal pipelines only. For proper performance, a straight pipe run of 12 pipe diameters upstream and 3 pipe diameters downstream of the switch is recommended.

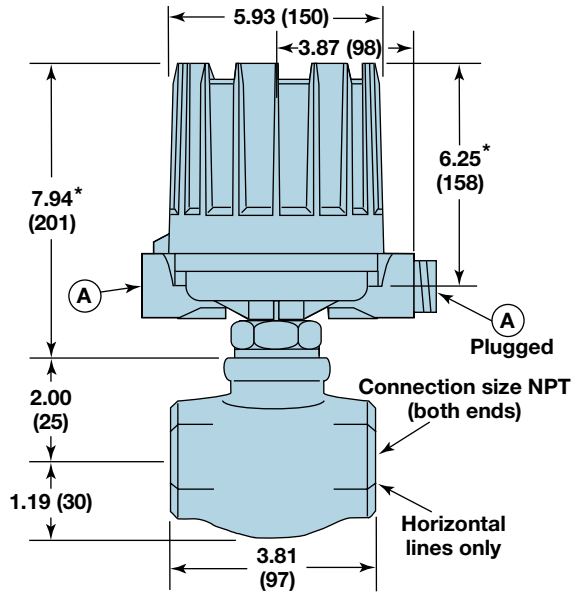

F50 Flow Switch with 3/4" or 1" NPT Internal Pipe, Bronze or Stainless Steel Body

Conduit Connections A
Electrical Switches: 1" NPT
Pneumatic Switches: 1/4" NPT

All housings rotatable 360°

Note:

Allow the following for overhead clearance for cover removal:

- Carbon Steel (pneumatic).....8.00(203)
- Aluminum.....10.00 (254)

* These dimensions increase by 2.19 (55) when used with Series HS switch with terminal block.

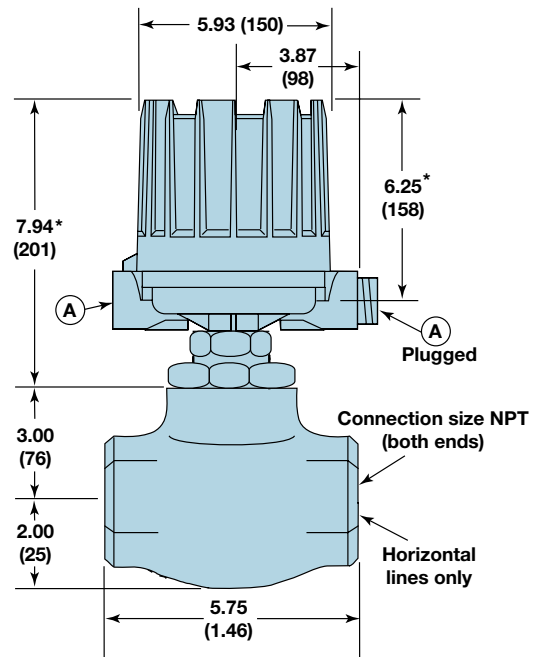

F50 Flow Switch with 1 1/2" or 2" NPT Internal Pipe, Bronze or Stainless Steel Body

ACTUATING FLOW RATES (WATER SERVICE)

Model F10 units may be adjusted in service to actuate within the minimum and maximum flow rates given

below. A specific gravity correction factor is applied for liquids other than water (1.00 specific gravity).

Pipe Line Size Inches ^①	Flow Increase (GPM)		Flow Decrease (GPM)	
	Minimum	Maximum ^②	Minimum	Maximum
2	21	63	16	48
2½	26	74	20	56
3	32	88	24	65
3½	38	100	28	75
4	45	120	33	85
5	61	150	43	110
6	79	180	55	130
8	120	230	82	160
10	170	310	110	210
12	230	380	150	250
14	270	430	170	280
16	340	510	220	320
18	430	590	270	370
20	520	690	320	430
22	620	780	380	480
24	730	900	450	550
26	850	1030	520	620
28	980	1160	590	700
30	1110	1290	670	780

^① Based upon Schedule 40 pipe

^② Consult factory for higher flow rates.

F10 MODEL NUMBER

MODEL NUMBER CODE

	Mounting Connection	Trim	Magnetic Sleeve	Pressure
F10-1	Carbon steel	304 and 316 stainless steel	316 stainless steel	1000 psig @ +450 °F (69 bar @ +232 °C)
F10-3	304 stainless steel	304 and 316 stainless steel	316 stainless steel	1000 psig @ +450 °F (69 bar @ +232 °C)
F10-4	316 stainless steel	316 stainless steel	316 stainless steel	1000 psig @ +450 °F (69 bar @ +232 °C)

On flanged models, standoffs are carbon steel with Model F10-1 and 316 stainless steel on Models F10-3 and F10-4. Consult factory for Steam applications.

PIPELINE CONNECTION

Connection Type	Vane Sized for Flow Line				
	2"	4"	6"	8"	10"
2" NPT	D22	D24	D26	D28	D20
2½" 150 lb. ANSI raised face flange	n/a	E54	E56	E58	E50
2½" 300 lb. ANSI raised face flange	n/a	E64	E66	E68	E60
2½" 600 lb. ANSI raised face flange	n/a	E74	E76	E78	E70

Consult factory for flow lines above 10" or larger flange sizes and installations over Sch. 160 when using flanged Model F10.

PNEUMATIC SWITCH MECHANISM AND ENCLOSURE

Switch Description	Maximum Supply Pressure		Maximum Process Temperature		Bleed Orifice Diameter		NEMA 1
	psig	bar	° F	° C	inches	mm	
Series J Bleed Type	100	7	+400	+204	0.063	1.6	JGF
	60	4	+400	+204	0.094	2.4	JHF
	60	4	+400	+204	0.055	1.4	JJF
Series K Non-Bleed	100	7	+400	+204	—	—	KOF
	40	3	+400	+204	—	—	—

ELECTRIC SWITCH MECHANISM AND ENCLOSURE

Switch Description	Maximum Process Temperature °F (°C) ①	One Set Point	Aluminum Enclosure ② ③		
			FM (US/CA) Groups C&D 1" NPT	FM (US/CA) Group B 1" NPT	ATEX IECEx 1" NPT
Series B snap	+250 (+121)	SPDT DPDT	BKB BNB	BKK BNK	BC9 BF9
Series C snap	+450 (+232)	SPDT DPDT	CKB CNB	CKK CNK	CC9 CF9
Series D snap for DC current applications	+250 (+121)	SPDT DPDT	DKB DNB	DKK DNK	DC9 DF9
Series HS 5 amp hermetically sealed snap with wiring leads	+450 (+232)	SPDT DPDT	HMJ HMS	HMK HMT	n/a n/a
Series HS 5 amp hermetically sealed snap with terminal block	+450 (+232)	SPDT DPDT	HM3 HM7	HM4 HM8	HA9 HB9

① Process temperatures based on +100 °F (+38 °C) ambient.

② Uncontrolled housing heater or drain available in TYPE 4X/7/9 enclosures.

③ Consult factory for TYPE 4X/7/9 cast iron housings.

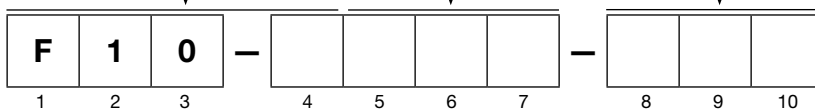

F50 MODEL NUMBER

MODEL NUMBER CODE

	Body	Trim	Magnetic Sleeve	Pressure Ratings
F50-1	Bronze	300 series stainless steel	400 series stainless steel	1100 psi @ +100 °F (75.8 bar @ 38 °C) 750 psi @ +500 °F maximum (51.7 bar @ 260 °C maximum)
F50-4	316 stainless steel	316 stainless steel	316 stainless steel	1150 psi @ +100 °F (79.2 bar @ 38 °C) 900 psi @ +750 °F maximum (62 bar @ 399 °C maximum)

PIPE SIZE

A2	¾" pipe size with ¾" NPT connections
B2	1" pipe size with 1" NPT connections
C2	1½" pipe size with 1½" NPT connections
D2	2" pipe size with 2" NPT connections

ACTUATING FLOW RATE

Pipe size	Actuating Flow Rate, GPM Water Flow, Increasing and Decreasing Rate					
	A	B	C	D	E	F
¾" NPT	n/a n/a	1.1 increasing 0.8 decreasing	1.6 increasing 1.2 decreasing	2.3 increasing 1.8 decreasing	3.4 increasing 2.6 decreasing	4.9 increasing 3.7 decreasing
1" NPT	1.0 increasing 0.8 decreasing	1.7 increasing 1.4 decreasing	2.5 increasing 2.1 decreasing	3.7 increasing 3.0 decreasing	5.5 increasing 4.5 decreasing	7.1 increasing 5.8 decreasing
1½" NPT	1.3 increasing 1.1 decreasing	2.7 increasing 2.3 decreasing	4.7 increasing 4.0 decreasing	7.6 increasing 6.5 decreasing	12.3 increasing 10.3 decreasing	21.1 increasing 17.9 decreasing
2" NPT	1.9 increasing 1.6 decreasing	3.1 increasing 2.7 decreasing	5.1 increasing 4.3 decreasing	8.4 increasing 7.1 decreasing	14.3 increasing 12.1 decreasing	24.8 increasing 21.0 decreasing

PNEUMATIC SWITCH MECHANISM AND ENCLOSURE

Switch Description	Max. Process Temp. °F (°C) ① ②	Maximum Supply Pressure	Bleed Orifice Diameter	Body Material	Pipe Size (NPT)	Flow Rate	NEMA 1
Series J bleed type	+550 (+288)	100 psig (7 bar)	0.063" (1.6 mm)	Bronze	¾" or 1"	A thru F	JDG
				Bronze	1½" or 2"	A thru D E and F	
		60 psig (4 bar)	0.094" (2.4 mm)	Stainless Steel	¾" thru 2"	A thru F	JDE
				Bronze	¾" or 1"	A thru F	JEG
Series K non-bleed type	+550 (+288)	100 psig (7 bar)	n/a	Bronze	¾" or 1"	A thru D E and F	KOE
				Stainless Steel	¾" thru 2"	A thru F	
		40 psig (3 bar)	n/a	Bronze	¾" thru 1"	A thru F	KOG
				Bronze	1½" or 2"	A thru D	



F50 MODEL NUMBER (CONTINUED)

ELECTRIC SWITCH MECHANISM AND ENCLOSURE

Switch Description	Maximum Process Temperature Range F (°C)	One Set Point	Body Material	Pipe Size (NPT)	Flow Rate	Aluminum Enclosure		
						FM (US/CA) Groups C&D 1" NPT	FM (US/CA) Group B 1" NPT	ATEX/IECEX 1" NPT
Series B snap	-40 to +250 (-40 to +121)	SPDT	Bronze	¾" or 1"	A thru F	BKP	BKT	BAC
				1½" or 2"	A thru D			
			E and F	BKQ	BKS	BA9		
		Stainless Steel	¾" thru 2"				A thru F	
		DPDT	Bronze	¾" or 1"	A thru F	BNP	BNT	BBC
				1½" or 2"	A thru D			
E and F	BNQ		BNS	BB9				
Stainless Steel		¾" thru 2"			A thru F			
Series C snap	-40 to +450 (-40 to +232)	SPDT	Bronze	¾" or 1"	A thru F	CKP	CKT	CAC
				1½" or 2"	A thru D			
			E and F	CKQ	CKS	CA9		
		Stainless Steel	¾" thru 2"				A thru F	
		DPDT	Bronze	¾" or 1"	A thru F	CNP	CNT	CBC
				1½" or 2"	A thru D			
E and F	CNQ		CNS	CB9				
Stainless Steel		¾" thru 2"			A thru F			
Series D snap for DC current applications	-40 to +250 (-40 to +121)	SPDT	Stainless Steel	¾" thru 2"	A thru F	DKQ	DKS	DA9
		DPDT				DNQ	DNS	DB9
Series F snap	-40 to +750 (-40 to +399)	SPDT	Bronze	¾" or 1"	A thru F	FKP	FKT	FAC
				1½" or 2"	A thru D			
			E and F	FKQ	FKS	FA9		
		Stainless Steel	¾" thru 2"				A thru F	
		DPDT	Bronze	¾" or 1"	A thru F	FNP	FNT	FBC
				1½" or 2"	A thru D			
E and F	FNQ		FNS	FB9				
Stainless Steel		¾" thru 2"			A thru F			
Series HS snap 5 amp hermetically sealed w/ wiring leads	-50 to +550 (-46 to +288) ③	SPDT	Bronze	1½" thru 2" ④	A thru F	HMC	HEK	n/a
		DPDT	Bronze	1½" thru 2" ④	A thru F	HMF	HET	n/a
Series HS snap 5 amp hermetically sealed w/ terminal block	-50 to +550 (-46 to +288) ③	SPDT	Bronze	1½" thru 2" ④	A thru F	HM3	HM4	HA9
		DPDT	Bronze	1½" thru 2" ④	A thru F	HM7	HM8	HB9

- ① Process temperatures based on -40 to +160 °F (-40 to +71 °C).
- ② Bronze models are rated to a maximum process temperature of +500 °F (+260 °C). Stainless steel models are limited to the maximum temperature of the selected switch mechanism.
- ③ On steam applications, temperature down-rated to +400 °F (+204 °C) process at +100 °F (+40 °C) ambient.
- ④ On models with bronze bodies ¾" or 1" NPT pipe sizes, consult factory for HS switches.



QUALITY



The quality assurance system in place at AMETEK LMS guarantees the highest level of quality throughout the company. AMETEK LMS is committed to providing full customer satisfaction both in quality products and quality service.

The AMETEK LMS quality assurance system is registered to ISO 9001 affirming its commitment to known international quality standards providing the strongest assurance of product/service quality available.

WARRANTY



All AMETEK LMS mechanical level and flow controls are warranted free of defects in materials or workmanship for three full years from the date of original factory shipment.

If returned within the warranty period; and, upon factory inspection of the control, the cause of the claim is determined to be covered under the warranty; then, AMETEK LMS will repair or replace the control at no cost to the purchaser (or owner) other than transportation.

AMETEK LMS shall not be liable for misapplication, labor claims, direct or consequential damage or expense arising from the installation or use of equipment. There are no other warranties expressed or implied, except special written warranties covering some AMETEK LMS products.

For additional information on the Models F10 and F50, see Instruction Manual 47-602.



ametech-measurement.com

705 Enterprise Street • Aurora, Illinois 60504-8149 USA
630.969.4000 • info.magnetrol@ametech.com

Copyright © 2025 AMETEK Magnetrol USA, LLC

Performance specifications are effective with date of issue and are subject to change without notice.

BULLETIN: 47-116.28
EFFECTIVE: October 2024
SUPERSEDES: October 2020