



MAGNETROL®

AMETEK®

**LEVEL MEASUREMENT
SOLUTIONS**

E4 Modulelevel® Liquid Level Displacer Transmitter

DESCRIPTION

The E4 Modulelevel® is a loop powered, two-wire instrument, utilizing simple buoyancy principles to detect and convert liquid level changes into a stable output signal. The linkage between the level sensing element and output electronics provides a purely mechanical design and construction. The vertical in-line design of the transmitter results in low instrument weight and simplified installation. The instrument comes in a variety of configurations and pressure ratings for varied applications.

The E4 Modulelevel has microprocessor-based electronics with 4–20 mA/HART® digital output. E4 supports the FDT/DTM standard and a PACTware™ PC software package allows for additional configuration, diagnostics, and trending capabilities.

TECHNOLOGY

Changing buoyancy forces caused by liquid level change act upon the spring supported displacer causing vertical motion of the core within a linear variable differential transformer.

As the core position changes with liquid level, voltages are induced across the secondary windings of the LVDT. These signals are processed in the electronic circuitry and converted to a useable output signal. The enclosing tube acts as a static isolation barrier between the LVDT and the process media.



APPLICATIONS

MEDIA: Liquids or slurries, clean or dirty, light hydrocarbons to heavy acids (SG=0.23 to 2.20)

VESSELS: Process & storage, bridles, bypass chambers, interface, sumps & pits up to unit pressure & temperature ratings.

CONDITIONS: Most liquid level measurement and control applications including those with varying dielectric, vapors, turbulence, foam, buildup, bubbling or boiling and high fill/empty rates; liquid/liquid interface level measurement or density control.

FEATURES

- Range Spring/LVDT design yields performance benefits over traditional torque tube displacer transmitters
- Easy to commission: local user interface adapted from the latest Magnetrol transmitter releases with graphic LCD available
- No level change required for configuration; no field calibration necessary
- Safety Integrity Level (SIL) 2 Suitable
- HART® digital communication (Version 7) with DD and graphical DTM for use with PACTware
- Various field calibration options available; including under process conditions or in the instrument shop
- Follows NAMUR NE 43 and NAMUR NE 107 (diagnostic coverage)
- A variety of installation methods including external chambers/cages (sold separately — see bulletin 41-143)
- Full range of hazardous location approvals with international certifications
- Order the entire Modulelevel (E4M) or retrofit the latest transmitter onto existing displacer assemblies (E4T)

INTERFACE

E4 Modulelevel is capable of tracking the interface level of two immiscible liquids with different densities. Each unit is custom-made with a displacer specially designed for the user's application. This allows it to detect the position of a clean interface or an emulsion layer and convert it into a stable 4–20 mA signal. Contact the factory for assistance in specifying an E4 for interface service. Note that for proper interface detection, the entire displacer must always be immersed in liquid.

SPECIFIC GRAVITY

Yet another capability of E4 Modulelevel is to track the changing specific gravity of a liquid over a known range and convert that into a stable 4–20 mA output signal. As the density of the liquid changes, so does the mass of the liquid displaced by the specially designed displacer. The resulting change in buoyancy force on the displacer causes the movement of the LVDT core necessary to convert the specific gravity change to the 4–20 mA signal.

PACTware™ PC SOFTWARE

PACTware PC software and the Field Device Tool (FDT) standard take level measurement to a new degree of setup efficiency and user-friendliness. PACTware adds a graphical software interface for increased ease of use. Simply connect your PC through a serial interface to the HART loop and all functionality can be accessed conveniently, and safely.

SPECIFICATIONS

FUNCTIONAL

System Design	
Measurement Principle	Buoyancy – continuous displacement utilizing a precision range spring
Input	
Measured Variable	Level, determined by LVDT core movement affected by buoyancy force changes on continuous displacer
Physical Range	Up to 300 cm (120") based on displacer length
Output	
Type	4 to 20 mA with HART: 3.8 to 20.5 mA usable (per NAMUR NE 43)
Resolution	0.01 mA Digital Display: 1 mm
Loop Resistance (maximum)	591 ohms @ 24 VDC and 22 mA (see loop resistance chart)
Diagnostic Alarm	3.6, 22 mA or HOLD last output (per NAMUR NE 43)
Damping	Adjustable 0–45 seconds

SPECIFICATIONS

FUNCTIONAL (continued)

User Interface	
Keypad	4-button menu-driven data entry
Display	Graphic Liquid Crystal Display
Digital Communication	HART Version 7 - with Field Communicator, AMS, or FDT DTM (PACTware), EDDL
Menu Languages	Transmitter LCD options: English, French, German, Spanish, Russian, Portuguese, Polish
	HART DD options: English, French, German, Spanish, Russian, Portuguese, Polish, Chinese
Power	
Voltage (Measured at Instrument Terminals)	11–36 VDC under certain conditions (see transmitter terminal voltage table)
Housing	
Material	Die-cast aluminum A413 (< 0.4% copper); optional stainless steel
Cable Entry	½" NPT or M20
SIL 2 Hardware (Safety Integrity Level)	Functional Safety to SIL 2 as 1oo1 in accordance with IEC 61508 (Full FMEDA report available upon request)
Displacer Assembly Materials	
Flange	Carbon steel or 316/316L stainless steel (selectable)
Enclosing tube	316/316L stainless steel
Stem	316/316L stainless steel
Displacer	316/316L stainless steel
Spring	Inconel (specific alloy is based on process conditions and model selection)
Process Conditions	
Process Temperature Range ①	Steam applications: -29 to +260 °C (-20 to +500 °F)
	Non-steam applications: -29 to +445 °C (-20 to +835 °F) ②
Process Pressure Range	348 bar @ +38 °C (5050 psig @ +100 °F)
Environment	
Electronics Operating Temperature	-40 to +80 °C (-40 to +176 °F)
Display Function Operating Temperature	-20 to +70 °C (-5 to +160 °F)
Storage Temperature	-40 to +85 °C (-50 to +185 °F)
Humidity	0-99%, non-condensing
Electromagnetic Compatibility	Meets CE Requirement: EN 61326
Surge Protection	Meets CE Requirements EN 61326
Shock Class	ANSI/ISA-S71.03 Class SA1 ③
Vibration Class	ANSI/ISA-S71.03 Class VC2 ③
Altitude	≤2000 m
Pollution Degree	2

① Maximum process temperatures are based on ambient temperatures less than or equal to +49 °C (+120 °F). Higher ambient temperatures require reduced process temperatures.

② Consult factory for low temperature applications down to -200 °C (-330 °F).

③ With aluminum housing only. Does not apply to models with 316 SS transmitter housings.

SPECIFICATIONS

PERFORMANCE – LEVEL

Reference Conditions	Water @ +21 °C (+70 °F) with 356 mm (14") displacer; wet calibration
Linearity	±0.50% of full span
Repeatability	±0.20% of full span
Ambient temperature effect	Maximum zero shift is 0.017%/°F over ambient temperature range
Operating Temp. range:	-40 to +80 °C (-40 to +176 °F)
LCD Temp. Range:	-20 to +70 °C (-5 to +160 °F)
Hysteresis	±0.20% of full span
Response Time	<1 second
Initialization Time	<5 seconds

PERFORMANCE – INTERFACE LEVEL & SPECIFIC GRAVITY ④

Linearity	±0.70% of full span
Repeatability	±0.40% of full span
Ambient Temperature Effect	Maximum zero shift is 0.017%/°F over ambient temperature range

④ The displacer must always be completely immersed in process liquid when the E4 is used in interface or density service. Top mounted models require liquid level to exceed the top of the displacer by 51 mm (2") at all times to ensure optimal performance.

AGENCY APPROVALS



These devices are in compliance with the RED-directive 2014/53/EU, the EMC directive 2014/30/EU, the PED-directive 2014/68/EU, the ATEX directive 2014/34/EU and RoHS directive 2011/65/EU.

<p>Explosion Proof</p> <p>US/Canada – FM23US0028X/FM23CA0021X: Class I, Div 1, Group B, C and D, T5 SINGLE SEAL Ta = -40°C to +80°C Type 4X, IP66, IP67</p> <p>Flame Proof</p> <p>ATEX – FM23ATEX0017X/FM23UKEX0024X: II 2 G Ex db IIC T6...T1 Ga/Gb Ta = -40°C to +70°C IP66, IP67</p> <p>IEC – IECEX FMG 23.0009X: Ex db IIC T6...T1 Ga/Gb Ta = -40°C to +70°C IP66, IP67</p>	<p>Intrinsically Safe</p> <p>US/Canada – FM23US0028X/FM23CA0021X Class I, II, III, Div 1, Group A, B, C, D, E, F, G, T4 Ta = -40°C to + 80°C Type 4X, IP66, IP67</p> <p>ATEX – FM23ATEX0017X/FM23UKEX0024X: II 1 G Ex ia IIC T4 Ga Ta = -40°C to +70°C IP66, IP67</p> <p>ATEX – FM23ATEX0025X/FM23UKEX0028X: II 3 G Ex ic IIC T4 Gc Ta = -40°C to +70°C IP66, IP67</p> <p>IEC – IECEX FMG 23.0009X: Ex ia IIC T4 Ga Ex ic IIC T4 Gc Ta = -40°C to +70°C IP66, IP67</p>
<p>Non- Incendive</p> <p>US/Canada – FM23US0028X/FM23CA0021X: US: Class I, II, III, Division 2, Group A, B, C, D, E, F, G, T4 Canada: Class I, Division 2, Group A, B, C, D SINGLE SEAL Ta = -40°C to +70°C Type 4X, IP66, IP67</p>	<p>Dust Ignition Proof</p> <p>US/Canada – FM23US0028X/FM23CA0021X: Class II, III, Division 1, Group E, F and G, T5 SINGLE SEAL Ta = -40°C to +80°C Type 4X, IP66, IP67</p>

AGENCY APPROVALS (continued)

On remote electronics housing only, seal is required at the enclosure.

See appropriate Installation & Operating Manual for entity parameters for IS installation.

Entity Parameters:

$$V_{\max} = 28.6 \text{ V} \quad P_{\max} = 1 \text{ W} \quad L_l = 2.7 \text{ } \mu\text{H}$$

$$I_{\max} = 140 \text{ mA} \quad C_i = 4.4 \text{ nF}$$

Reference Installation and Operating Manual 48-636 for special conditions of use and agency drawing.

LOOP RESISTANCE

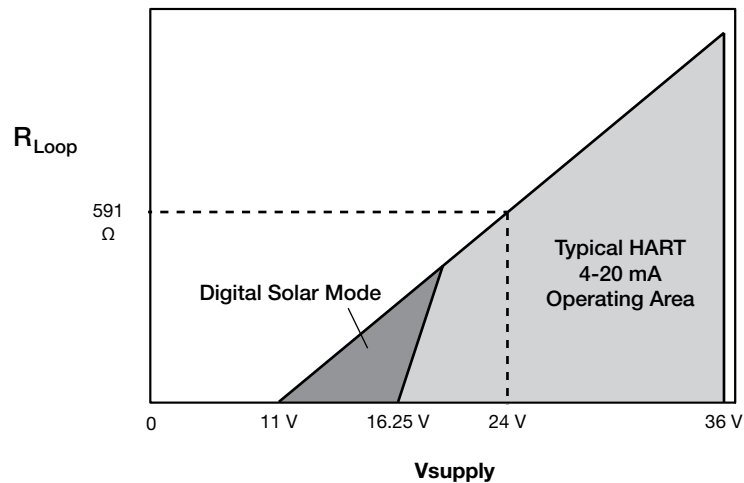

TRANSMITTER TERMINAL VOLTAGE

Operational Mode	Current Consumption	Vmin	Vmax
HART			
General Purpose	4mA	16.25V	36V
	20mA	11V	36V
Intrinsically Safe	4mA	16.25V	28.6V
	20mA	11V	28.6V
Explosion Proof	4mA	16.25V	36V
	20mA	11V	36V
Fixed Current-Solar Power Operation (PV transmitted via HART)			
General Purpose	10mA ①	11V	36V
Intrinsically Safe	10mA ①	11V	28.6V
HART Multi-Drop Mode (Fixed Current)			
Standard	4mA ①	18V ②	36V
Intrinsically Safe	4mA ①	18V ②	28.6V

① Start-up current 12 mA minimum.

② Allows for loop resistance of at least 250 ohms.

E4 MODULE LEVEL DIMENSIONAL SPECIFICATIONS

inches (mm)

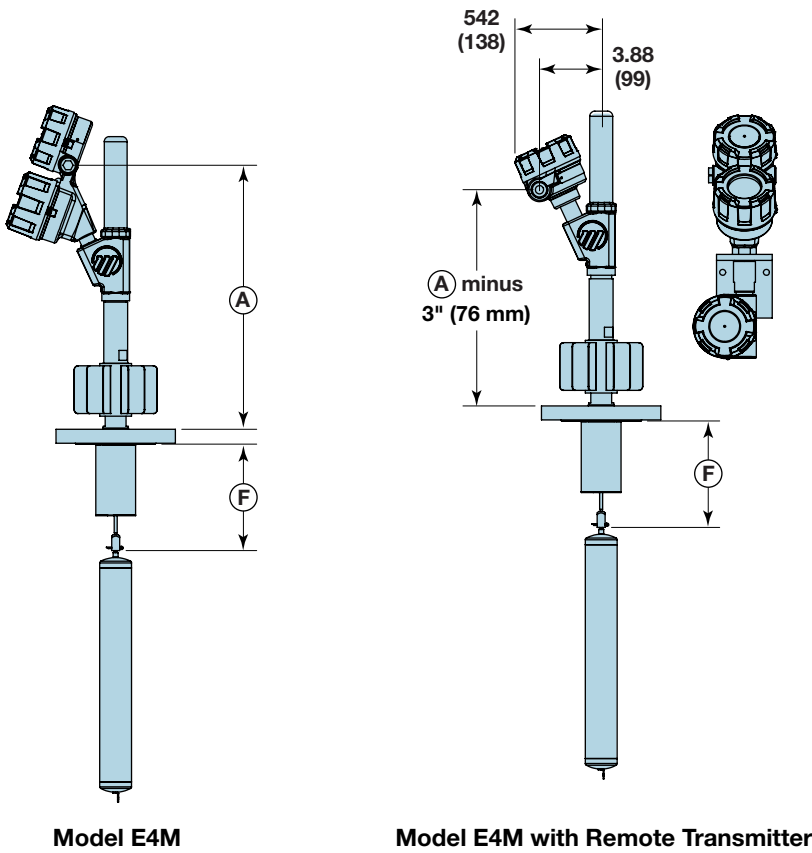

Digit 9	Dim A
A	12.58 (319.5)
B, C	16.58 (421.1)
D, E, H	20.58 (522.7)
F, G, J	24.58 (624.3)

Digits			Dim F
10th	12th	15th	
0	3, 4, 5, K, A, C, D, E, W, Z	A	8.69 (220.7)
		B	8.88 (226.6)
		C	9.25 (235)
		D	9.25 (235)
		E	9.19 (233.4)
		F	9.19 (233.4)
		G	9.19 (233.4)
		H	9.38 (238.3)
		I	9.38 (238.3)
1	3, 4, 5, K, A, C, D, E, W, Z	A	6.69 (169.9)
		B	6.88 (174.8)
		C	7.25 (184.2)
		D	7.25 (184.2)
		E	7.19 (182.6)
		F	7.19 (182.6)
		G	7.19 (182.6)
		H	7.38 (187.5)
		I	7.38 (187.5)
2	3, 4, 5, K, A, C, D, E, W, Z	A	6.69 (169.9)
		B	6.88 (174.8)
		C	7.25 (184.2)
		D	7.25 (184.2)
		E	7.19 (182.6)
		F	7.19 (182.6)
		G	7.19 (182.6)
		H	7.38 (187.5)
		I	7.38 (187.5)
3	6, 7, 8, F, G, H, J, L, M, N	A	8.81 (223.8)
		B	8.94 (227.1)
		C	8.94 (227.1)
		D	8.94 (227.1)

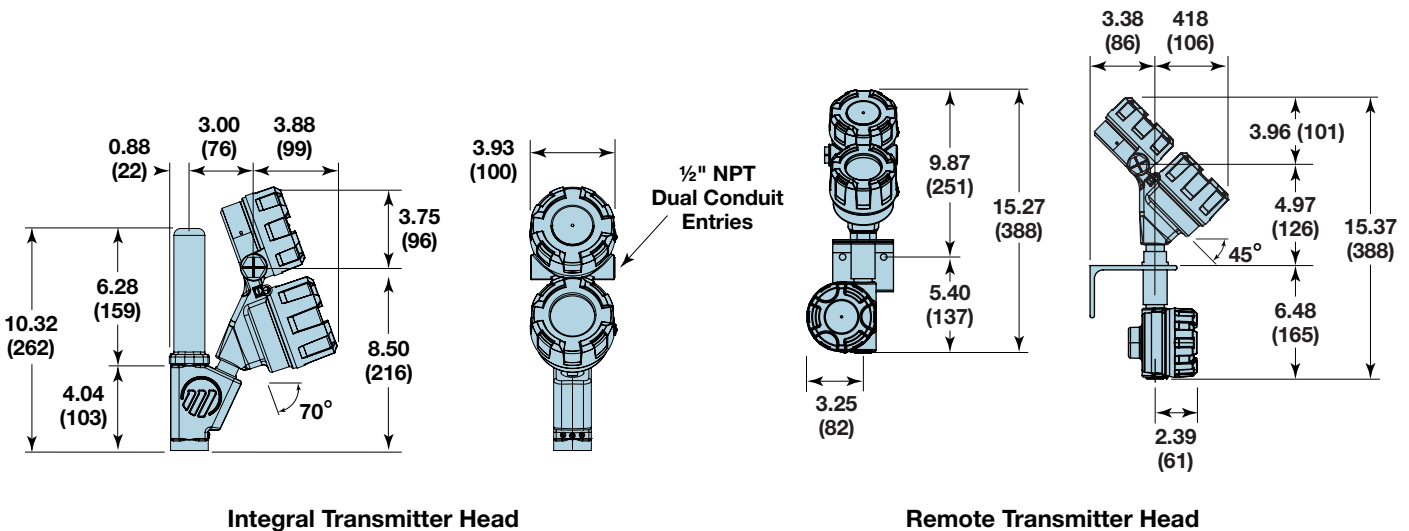

E4 CHAMBER DIMENSIONAL SPECIFICATIONS

inches (mm)

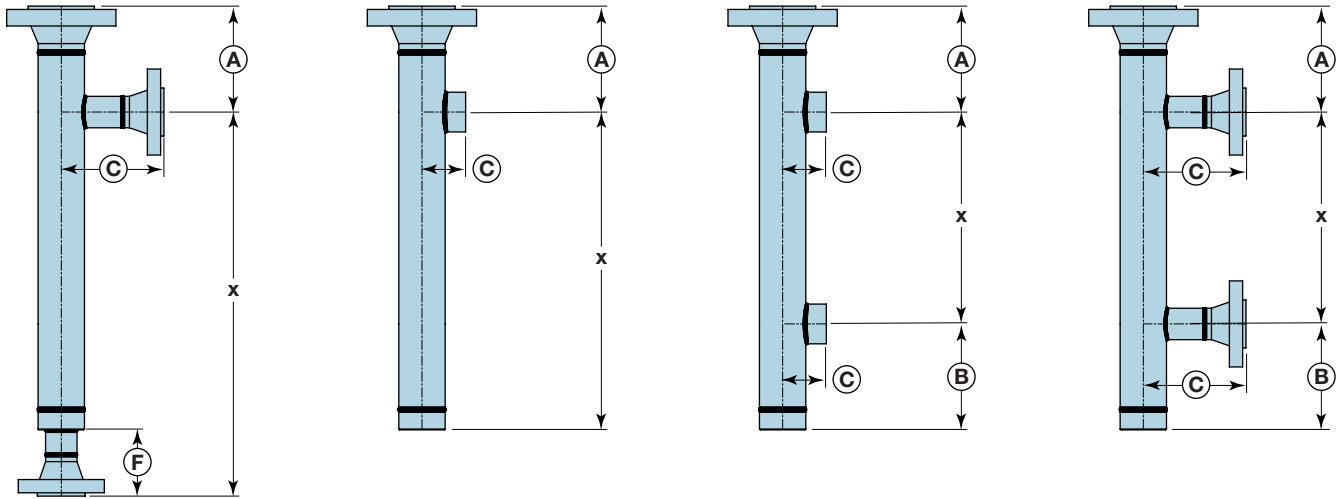

Dim		150#	300#	600#	900#	1500#	2500#
		PN25	PN40	PN100	PN160	PN250	PN320
A	Digit 16 = 'R'	7.31 (186)	7.31 (186)	7.31 (186)	N/A	N/A	N/A
	Digit 16 = 'S'	9.31 (236)	9.31 (236)	9.31 (236)	9.31 (236)	9.31 (236)	9.31 (236)
	Digit 16 = 'T'	12.62 (321)	12.62 (321)	12.62 (321)	12.62 (321)	12.62 (321)	12.62 (321)
B	Side/side only	6.00 (152)	6.00 (152)	6.00 (152)	6.00 (152)	6.00 (152)	6.00 (152)
	Flanged (SO)	6.12 (155)	6.12 (155)	6.12 (155)	6.12 (155)	6.12 (155)	N/A
C	Flanged (WN) - 1½"	6.27 (159)	6.52 (166)	6.83 (173)	6.64 (169)	7.33 (186)	8.46 (215)
	Flanged (WN) - 2"	6.33 (161)	6.58 (167)	6.96 (177)	7.58 (193)	8.27 (210)	9.27 (235)
	Flanged (WN) - DN40	5.60 (142)	5.60 (142)	6.27 (159)	5.66 (144)	6.98 (177)	7.30 (185)
	Flanged (WN) - DN50	5.69 (145)	5.69 (145)	6.51 (165)	6.28 (160)	7.37 (187)	7.96 (202)
	NPT-F 1½"	2.98 (76)	2.98 (76)	2.98 (76)	3.19 (81)	3.19 (81)	C/F
	NPT-F 2"	2.96 (75)	2.96 (75)	2.96 (75)	3.19 (81)	3.19 (81)	C/F
	SW 1½"	3.36 (85)	3.36 (85)	3.36 (85)	3.19 (81)	3.19 (81)	C/F
	SW 2"	3.71 (94)	3.71 (94)	3.71 (94)	3.19 (81)	3.19 (81)	C/F
F	Flanged Side/bottom	6.00 (152)	6.00 (152)	6.00 (152)	8.00 (203)	8.00 (203)	10.00 (254)
	NPT/SW Side/bottom	0.00	0.00	0.00	0.00	0.00	0.00

X for SIDE/SIDE = Level Range

X for SIDE/BOTTOM = Level Range + 4.00" + 'DIM F'

MODEL NUMBER

E4 TRANSMITTER WITH DISPLACER ASSEMBLY

DESIGN TYPE

E 4 M	E4 Module level — Liquid Level Displacer Transmitter
--------------	--

POWER

5	24 VDC, Two-Wire
----------	------------------

SIGNAL OUTPUT

1	4–20 mA with HART
----------	-------------------

ACCESSORIES

0	No Digital Display or Keypad; No other accessories included
1	No Digital Display or Keypad; Adjustable displacer hanger cable included (8' / 2.5m standard)
2	No Digital Display or Keypad; External Chamber included ① ②
A	Digital Display and Keypad included; No other accessories included
B	Digital Display and Keypad included; Adjustable displacer hanger cable included (8' / 2.5m standard)
C	Digital Display and Keypad included; External Chamber included ① ②

① Hanger cable is not necessary for planned installation into external chamber.

② Select chamber model number separately. See Universal Chamber bulletin 41-143.

CLASSIFICATION

0	General Purpose, Weatherproof (IP66 & IP67)
1	Intrinsically Safe (Ex ia & Ex ic)
3	Explosion Proof / Flameproof (Ex db)
C	Non-Incendive
D	Dust Ignition Proof

HOUSING / CONDUIT CONNECTION ③

0	Integral Aluminum enclosure; ½" NPT
1	Integral Aluminum enclosure; M20 × 1.5
2	Integral SST enclosure; ½" NPT
3	Integral SST enclosure; M20 × 1.5
A	Remote Aluminum enclosure; ½" NPT ④
B	Remote Aluminum enclosure; M20 × 1.5 ④
C	Remote SST enclosure; ½" NPT ④
D	Remote SST enclosure; M20 × 1.5 ④

③ Sunshade available and sold separately.

④ Remote transmitter cable sold separately.

PROCESS TEMPERATURE

For Non-Steam (Non-Condensing) Applications	
A	Up to 150 °C; no heat extension
B	Up to 200 °C; 4" finned heat extension
D	Up to 230 °C; 4" plain + 4" finned heat extension
G	Up to 290 °C; 8" plain + 4" finned heat extension
H	Up to 315 °C; 4" plain + 4" finned heat extension
J	Up to 445 °C; 8" plain + 4" finned heat extension ⑤
For Steam (Condensing) Applications	
A	Up to 150 °C; no heat extension
C	Up to 200 °C; 4" finned heat extension
E	Up to 230 °C; 4" plain + 4" finned heat extension
F	Up to 260 °C; 8" plain + 4" finned heat extension

⑤ Remote enclosure only; Available only with Digit 10 = 1 (0.55-1.09 S.G.)



MODEL NUMBER

E4 TRANSMITTER WITH DISPLACER ASSEMBLY

SPECIFIC GRAVITY – LIQUID

0	0.23–0.54 ^⑥
1	0.55–1.09
2	1.10–2.20 ^⑥
9	Custom

^⑥ Up to 600# / PN 100 pressure class

PROCESS CONNECTION – HEAD FLANGE ^⑦

ASME FLANGES

5 3	3" 150# ASME RF
5 4	3" 300# ASME RF
5 5	3" 600# ASME RF
5 6	3" 900# ASME RF
5 7	3" 1500# ASME RF
5 K	3" 600# ASME RTJ
5 L	3" 900# ASME RTJ
5 M	3" 1500# ASME RTJ

6 3	4" 150# ASME RF
6 4	4" 300# ASME RF
6 5	4" 600# ASME RF
6 6	4" 900# ASME RF
6 7	4" 1500# ASME RF
6 8	4" 2500# ASME RF
6 K	4" 600# ASME RTJ
6 L	4" 900# ASME RTJ
6 M	4" 1500# ASME RTJ
6 N	4" 2500# ASME RTJ

7 3	6" 150# ASME RF
7 4	6" 300# ASME RF
7 5	6" 600# ASME RF
7 6	6" 900# ASME RF
7 7	6" 1500# ASME RF
7 8	6" 2500# ASME RT
7 K	6" 600# ASME RTJ

EN FLANGES

E D	DN 80, PN 63	EN 1092-1 TYPE B2
E E	DN 80, PN 100	EN 1092-1 TYPE B2
E F	DN 80, PN 160	EN 1092-1 TYPE B2
E G	DN 80, PN 250	EN 1092-1 TYPE B2
E H	DN 80, PN 320	EN 1092-1 TYPE B2
E W	DN 80, PN 16	EN 1092-1 TYPE B1
E Z	DN 80, PN 25/40	EN 1092-1 TYPE B1
F D	DN 100, PN 63	EN 1092-1 TYPE B2
F E	DN 100, PN 100	EN 1092-1 TYPE B2
F F	DN 100, PN 160	EN 1092-1 TYPE B2

F G	DN 100, PN 250	EN 1092-1 TYPE B2
F H	DN 100, PN 320	EN 1092-1 TYPE B2
F J	DN 100, PN 400	EN 1092-1 TYPE B2
F W	DN 100, PN 16	EN 1092-1 TYPE B1
F Z	DN 100, PN 25/40	EN 1092-1 TYPE B1
G D	DN 150, PN 63	EN 1092-1 TYPE B2
G E	DN 150, PN 100	EN 1092-1 TYPE B2
G W	DN 150, PN 16	EN 1092-1 TYPE B1
G Z	DN 150, PN 25/40	EN 1092-1 TYPE B1

^⑦ If installing Module into Magnetrol/Orion external chamber, select 3" (DN 80) up to 1500# (PN 250) construction & 4" (DN 100) up to 2500# (PN 400)

CONSTRUCTION CODES

0	Industrial
K	ASME B31.1
L	ASME B31.3
M	ASME B31.3 & NACE MR0175/MR0103
N	NACE MR0175/MR0103

MATERIAL OF CONSTRUCTION (E-TUBE/FLANGE/STEM/DISPLACER/HANGER CABLE)

A	316 SST flange, e-tube, stem, displacer and cable assembly (if applicable) ^⑧
R	Carbon Steel flange; 316 SST e-tube, stem, displacer and cable assembly (if applicable)

^⑧ Consult factory for 1500# (PN 250) construction or greater.

LEVEL RANGE/ DISPLACER LENGTH mm (inches)

All Pressures	
A	356 (14)
B	813 (32)
C	1219 (48)
D	1524 (60)
≤600# (PN 100)	
E	1829 (72)
F	2134 (84)
G	2438 (96)
H	2743 (108)
I	3048 (120)



MODEL NUMBER

E4 TRANSMITTER ONLY

DESIGN TYPE

E 4 T	E4 Modulelevel — Transmitter Only
--------------	-----------------------------------

POWER

5	24 VDC, Two-Wire
----------	------------------

SIGNAL OUTPUT

1	4–20 mA with HART
----------	-------------------

ACCESSORIES

0	No Digital Display or Keypad
A	Digital Display and Keypad included

CLASSIFICATION

0	General Purpose, Weatherproof (IP66 & IP67)
1	Intrinsically Safe (Ex ia & Ex ic)
3	Explosion Proof / Flameproof (Ex db)
C	Non-Incendive
D	Dust Ignition Proof

HOUSING / CONDUIT CONNECTION ^①

0	Integral Aluminum enclosure; ½" NPT
1	Integral Aluminum enclosure; M20 × 1.5
2	Integral SST enclosure; ½" NPT
3	Integral SST enclosure; M20 × 1.5
A	Remote Aluminum enclosure; ½" NPT ^②
B	Remote Aluminum enclosure; M20 × 1.5 ^②
C	Remote SST enclosure; ½" NPT ^②
D	Remote SST enclosure; M20 × 1.5 ^②

^① Sunshade available and sold separately.

^② Remote transmitter cable sold separately.

PROCESS TEMPERATURE ^③

For Non-Steam (Non-Condensing) Applications	
G	Up to 290 °C
J	Up to 445 °C
For Steam (Condensing) Applications	
A	Up to 150 °C
E	Up to 230 °C
F	Up to 260 °C

^③ Actual maximum temperature is based on existing field installation, including heat extensions and integral or remote electronics. Reference E4M Process Temperature digits to verify transmitter meets application requirement.

SPECIFIC GRAVITY — LIQUID

0	0.23–0.54
1	0.55–1.09
2	1.10–2.20
9	Custom

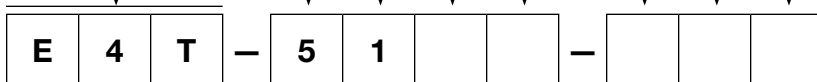

MODEL NUMBER

E4 CONNECTING CABLE

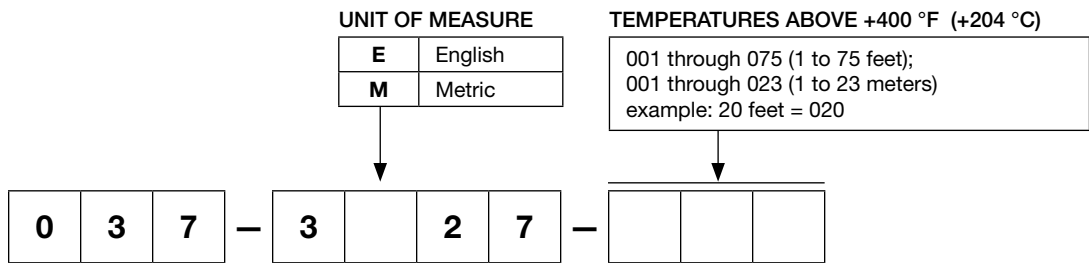
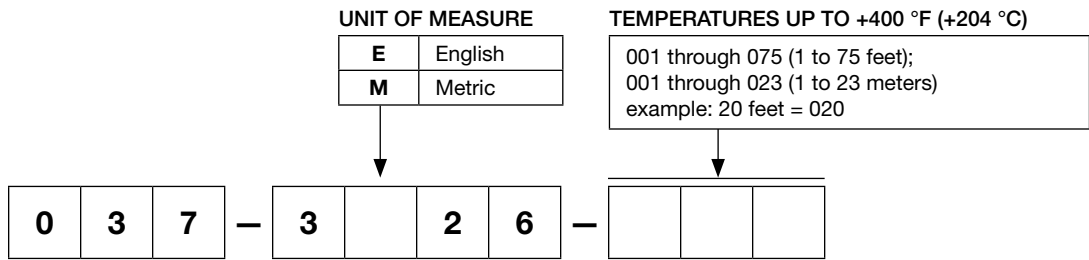

QUALITY

The quality assurance system in place at AMETEK LMS guarantees the highest level of quality throughout the company. AMETEK LMS is committed to providing full customer satisfaction both in quality products and quality service.

The AMETEK LMS quality assurance system is certified to ISO 9001, affirming our commitment to internationally recognized quality management standards and continuous improvement.

WARRANTY



All AMETEK LMS electronic level and flow controls are warranted free of defects in materials or workmanship for eighteen months from the date of original factory shipment.

If returned within the warranty period; and, upon factory inspection of the control, the cause of the claim is determined to be covered under the warranty; then, AMETEK LMS will repair or replace the control at no cost to the purchaser (or owner) other than transportation.

AMETEK LMS shall not be liable for mis-application, labor claims, direct or consequential damage or expense arising from the installation or use of equipment. There are no other warranties expressed or implied, except special written warranties covering some AMETEK LMS products.



AMETEK-Measurement.com

705 Enterprise Street • Aurora, Illinois 60504-8149 USA
630.969.4000 • info.magnetrol@ametek.com

Copyright © 2026 AMETEK Magnetrol USA, LLC

Performance specifications are effective with date of issue and are subject to change without notice.

BULLETIN: 48-136.0
EFFECTIVE: July 2023