

PS01 SERIES

POSITION SWITCH SOLID-STATE LEVEL CONTROL

DESCRIPTION

The PS01 Position Switch is a magnet-actuated device designed for use in the typical applications of safety interlocks, position indication, equipment automation, door interlocks, and other general purposes. Equipped with flange-type mounting attachments, the PS01 is easily installed into any application. Housing materials are available in Kynar, Nylon or Noryl with various switch types. Internal magnetic materials are Neodymium or Alnico. Cable lengths are made-to-order up to 99'.

PRINCIPLE OF OPERATION

As a magnet approaches the proximity switch, the internal reed switch changes state. The switch closure creates a continuous electrical path through the TRIAC, powering the connected load. Once the magnetic field is removed, the switch returns to its original state.

KEY FEATURES

- Two-Part Assembly:
Magnet Housing & Reed Switch Housing
- Encapsulated Reed Switch
- Easy Installation Flange-Type Mount
- UL-Approved
- No Calibration Required
- No Moving Parts

ENVIRONMENTAL

- Process Temperature:
-20 to +140 °F (-29 to +60 °C)



SPECIFICATIONS

MAGNET TYPE	SENSING RANGE	BREAK RANGE
Neodymium	1 3/8" NOM.	1 1/2" NOM.
Alnico	1" NOM.	1 1/4" NOM.

ELECTRICAL

- Input: 240 VAC Max.
- Output:
TRIAC (NO/NC) 1.25 Amp Max.

APPLICATIONS

-  Safety Interlocks
-  Position Indication
-  Equipment Automation



PS01

DIMENSIONS

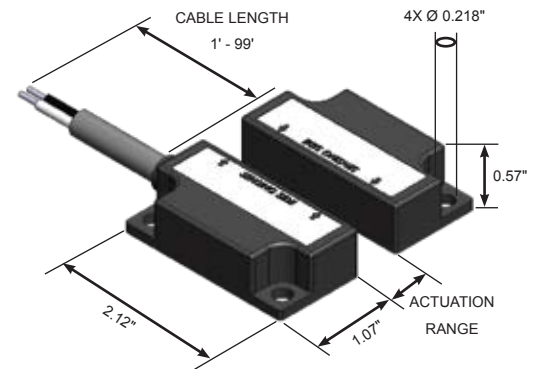

PS01

